

Machine Automation Controller

NX-series

CPU Unit Hardware

User's Manual

NX701-1□□□

NX-PA9001/PD7001

CPU Unit
Power Supply Unit



NOTE

All rights reserved. No part of this publication may be reproduced, stored in a retrieval system, or transmitted, in any form, or by any means, mechanical, electronic, photocopying, recording, or otherwise, without the prior written permission of OMRON.

No patent liability is assumed with respect to the use of the information contained herein. Moreover, because OMRON is constantly striving to improve its high-quality products, the information contained in this manual is subject to change without notice. Every precaution has been taken in the preparation of this manual. Nevertheless, OMRON assumes no responsibility for errors or omissions. Neither is any liability assumed for damages resulting from the use of the information contained in this publication.

Trademarks

- Sysmac and SYSMAC are trademarks or registered trademarks of OMRON Corporation in Japan and other countries for OMRON factory automation products.
- Microsoft, Windows, Windows Vista, Excel, and Visual Basic are either registered trademarks or trademarks of Microsoft Corporation in the USA and other countries.
- EtherCAT® is registered trademark and patented technology, licensed by Beckhoff Automation GmbH, Germany.
- ODVA, CIP, CompoNet, DeviceNet, and EtherNet/IP are trademarks of ODVA.
- The SD and SDHC logos are trademarks of SD-3C, LLC. 

Other company names and product names in this document are the trademarks or registered trademarks of their respective companies.

Copyrights

Microsoft product screen shots reprinted with permission from Microsoft Corporation.

Introduction

Thank you for purchasing an NX-series CPU Unit.

This manual contains information that is necessary to use the NX-series CPU Unit. Please read this manual and make sure you understand the functionality and performance of the NX-series CPU Unit before you attempt to use it in a control system.

Keep this manual in a safe place where it will be available for reference during operation.

Intended Audience

This manual is intended for the following personnel, who must also have knowledge of electrical systems (an electrical engineer or the equivalent).

- Personnel in charge of introducing FA systems.
- Personnel in charge of designing FA systems.
- Personnel in charge of installing and maintaining FA systems.
- Personnel in charge of managing FA systems and facilities.

For programming, this manual is intended for personnel who understand the programming language specifications in international standard IEC 61131-3 or Japanese standard JIS B 3503.

Applicable Products

This manual covers the following products.

- NX-series CPU Units
 - NX701-17□□
 - NX701-16□□

Part of the specifications and restrictions for the CPU Units are given in other manuals. Refer to *Relevant Manuals* on page 5 and *Related Manuals* on page 29.

CONTENTS

Introduction	1
Intended Audience.....	1
Applicable Products.....	1
CONTENTS.....	2
Relevant Manuals	5
Manual Structure	6
Page Structure.....	6
Special Information	7
Precaution on Terminology	7
Terms and Conditions Agreement.....	8
Warranty, Limitations of Liability	8
Application Considerations	9
Disclaimers	9
Safety Precautions	10
Definition of Precautionary Information.....	10
Symbols.....	10
Warnings.....	11
Cautions.....	13
Precautions for Safe Use.....	14
Precautions for Correct Use.....	22
Regulations and Standards	25
Conformance to EC Directives	25
Conformance to UL and CSA Standards.....	26
Conformance to KC Standards.....	26
Software Licenses and Copyrights	26
Versions	27
Checking Versions.....	27
Unit Versions of CPU Units and Sysmac Studio Versions	28
Related Manuals	29
Terminology	32
Revision History	37
Sections in this Manual	39

Section 1 Introduction to NX-series Controllers

1-1 The NX-series Controllers	1-2
1-1-1 Features.....	1-2
1-1-2 Introduction to the System Configurations	1-5
1-2 Specifications	1-8
1-3 Overall Operating Procedure for the NX-series Controller.....	1-12
1-3-1 Overall Procedure	1-12
1-3-2 Procedure Details.....	1-13

Section 2 System Configuration

2-1 Basic System Configuration	2-2
2-1-1 EtherCAT Network Configuration.....	2-3
2-2 Connecting to the Sysmac Studio	2-6
2-3 Network Configuration	2-7

Section 3 Configuration Units

3-1 CPU Units	3-2
3-1-1 Models and Specifications	3-2
3-1-2 Part Names and Functions	3-2
3-2 SD Memory Cards	3-10
3-2-1 Models and Specifications	3-10
3-2-2 Purpose	3-10
3-3 Power Supply Units	3-11
3-3-1 Models and Specifications	3-11
3-3-2 Part Names and Functions	3-12
3-4 Sysmac Studio	3-15
3-4-1 Model Numbers	3-15
3-4-2 Connection.....	3-15

Section 4 Installation and Wiring

4-1 Processing at Power ON and Power OFF	4-2
4-1-1 Power ON Operation	4-2
4-1-2 Power OFF Operation.....	4-3
4-1-3 Resetting the Controller from the Sysmac Studio.....	4-5
4-2 Fail-safe Circuits	4-6
4-2-1 Order of Powering Up the Controller and Controlled System.....	4-7
4-3 Mounting Units	4-9
4-3-1 Installation in a Control Panel	4-10
4-3-2 Preparations for Installation	4-14
4-3-3 Installing the CPU Module	4-16
4-3-4 Mounting the End Cover	4-20
4-3-5 Mounting the End Plates.....	4-21
4-3-6 Installing and Removing the SD Memory Card.....	4-23
4-3-7 Removing the CPU Module	4-27
4-3-8 Assembled Appearance and Dimensions.....	4-29
4-4 Wiring	4-31
4-4-1 Power Supply Wiring	4-31
4-4-2 Grounding	4-35
4-4-3 Wiring the Built-in EtherCAT Port	4-38
4-4-4 Wiring the Built-in EtherNet/IP Port	4-38
4-5 Control Panel Installation	4-39
4-5-1 Temperature.....	4-39
4-5-2 Humidity.....	4-41
4-5-3 Vibration and Shock.....	4-41
4-5-4 Atmosphere	4-41
4-5-5 Electrical Environment.....	4-42
4-5-6 Grounding.....	4-46

Section 5 Troubleshooting

5-1	Operation after an Error	5-2
5-1-1	Overview of NX-series Status	5-2
5-1-2	Fatal Errors in the CPU Unit.....	5-3
5-1-3	Non-fatal Errors in the CPU Unit.....	5-4
5-2	Troubleshooting	5-11
5-2-1	Checking to See If the CPU Unit Is Operating	5-11
5-2-2	Troubleshooting Flowchart for Non-fatal Errors	5-12
5-2-3	Error Table.....	5-13
5-2-4	Error Descriptions	5-23

Section 6 Inspection and Maintenance

6-1	Cleaning and Maintenance	6-2
6-1-1	Cleaning	6-2
6-1-2	Periodic Inspections	6-2
6-1-3	Unit Replacement Precautions.....	6-5
6-2	Replacing the Battery	6-6
6-2-1	Battery Replacement.....	6-6
6-2-2	Operation without a Battery.....	6-10
6-3	Replacing the Fan Unit	6-11
6-3-1	Purpose of Attaching the Fan Unit	6-11
6-3-2	Fan Unit Replacement Period	6-11
6-3-3	Fan Unit Used for Replacement.....	6-11
6-3-4	Procedure of Fan Unit Replacement.....	6-12

Appendices

A-1	Specifications	A-2
A-2	Dimensions	A-3
A-2-1	NX-series CPU Units.....	A-3
A-2-2	End Cover	A-4
A-2-3	NX-series Power Supply Units	A-4
A-2-4	SD Memory Card	A-5
A-3	Version Information	A-6

Index

Relevant Manuals

The following table provides the relevant manuals for the NX-series CPU Units. Read all of the manuals that are relevant to your system configuration and application before you use the NX-series CPU Unit.

Most operations are performed from the Sysmac Studio Automation Software. Refer to the *Sysmac Studio Version 1 Operation Manual* (Cat. No. W504) for information on the Sysmac Studio.

Purpose of use	Manual								
	Basic information			N/NX-series CPU Unit Motion Control User's Manual	N/NX-series Motion Control Instructions Reference Manual	N/NX-series CPU Unit Built-in EtherCAT Port User's Manual	N/NX-series CPU Unit Built-in EtherNet/IP Port User's Manual	N/NX-series Troubleshooting Manual	
	NX-series CPU Unit Hardware User's Manual	N/NX-series CPU Unit Software User's Manual	N/NX-series Instructions Reference Manual						
Introduction to NX-series Controllers	●								
Setting devices and hardware	●			●		●	●		
Using motion control									
Using EtherCAT									
Using EtherNet/IP									
Software settings		●		●		●	●		
Using motion control									
Using EtherCAT									
Using EtherNet/IP									
Writing the user program		●	●	●	●	●	●		
Using motion control									
Using EtherCAT									
Using EtherNet/IP									
Programming error processing								●	
Testing operation and debugging		●		●		●	●		
Using motion control									
Using EtherCAT									
Using EtherNet/IP									
Learning about error management and corrections*1	▲	▲		▲		▲	▲	●	
Maintenance	●			●		●	●		
Using motion control									
Using EtherCAT									
Using EtherNet/IP									

*1. Refer to the *N/NX-series Troubleshooting Manual* (Cat. No. W503) for the error management concepts and an overview of the error items. Refer to the manuals that are indicated with triangles for details on errors for the corresponding Units.

Manual Structure

Page Structure

The following page structure is used in this manual.

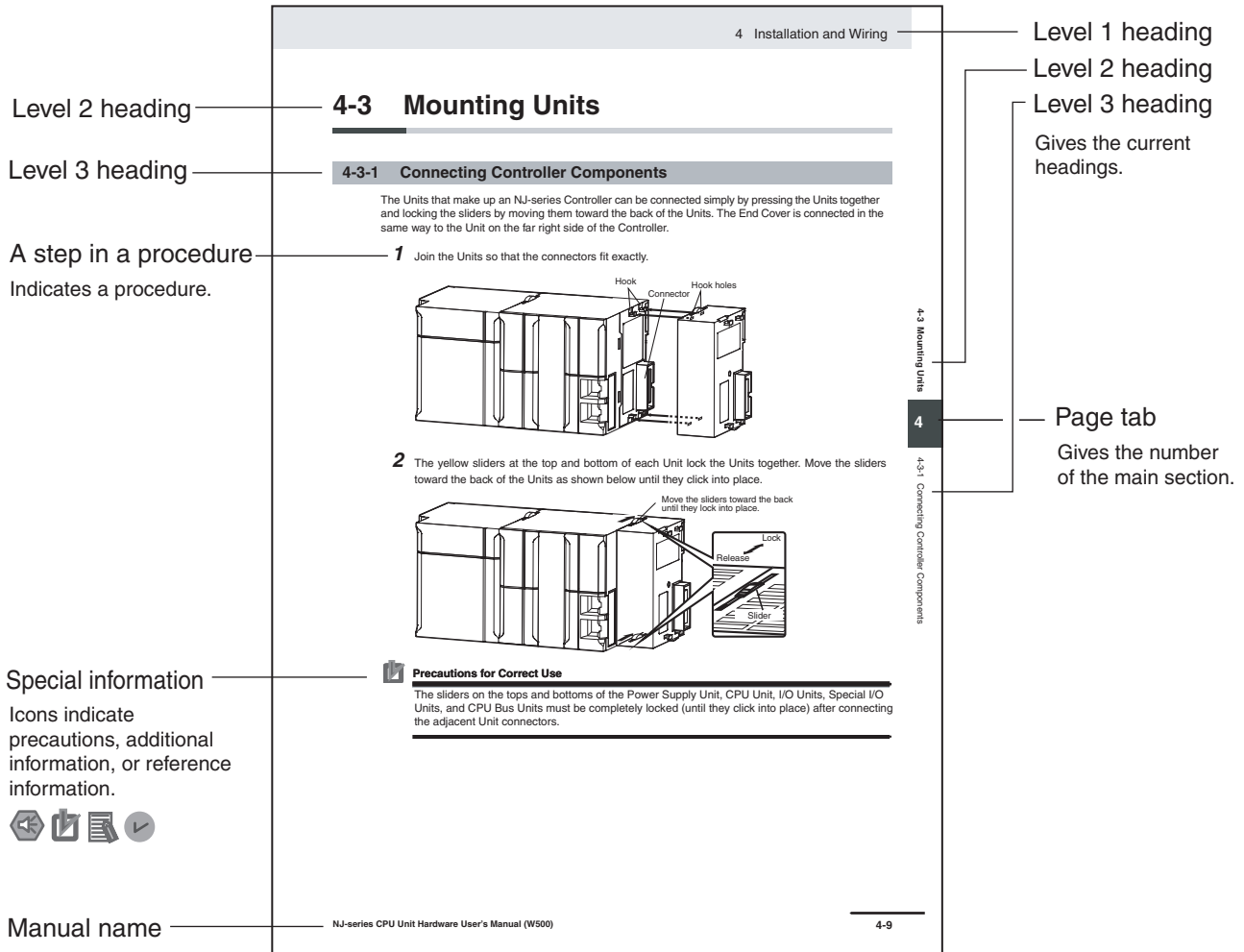

Note This illustration is provided only as a sample. It may not literally appear in this manual.

Special Information

Special information in this manual is classified as follows:



Precautions for Safe Use

Precautions on what to do and what not to do to ensure safe usage of the product.



Precautions for Correct Use

Precautions on what to do and what not to do to ensure proper operation and performance.



Additional Information

Additional information to read as required.

This information is provided to increase understanding or make operation easier.



Version Information

Information on differences in specifications and functionality for CPU Units with different unit versions and for different versions of the Sysmac Studio is given.

Note References are provided to more detailed or related information.

Precaution on Terminology

In this manual, “download” refers to transferring data from the Sysmac Studio to the physical Controller and “upload” refers to transferring data from the physical Controller to the Sysmac Studio.

For the Sysmac Studio, synchronization is used to both upload and download data. Here, “synchronize” means to automatically compare the data for the Sysmac Studio on the computer with the data in the physical Controller and transfer the data in the direction that is specified by the user.

Terms and Conditions Agreement

Warranty, Limitations of Liability

Warranties

● Exclusive Warranty

Omron's exclusive warranty is that the Products will be free from defects in materials and workmanship for a period of twelve months from the date of sale by Omron (or such other period expressed in writing by Omron). Omron disclaims all other warranties, express or implied.

● Limitations

OMRON MAKES NO WARRANTY OR REPRESENTATION, EXPRESS OR IMPLIED, ABOUT NON-INFRINGEMENT, MERCHANTABILITY OR FITNESS FOR A PARTICULAR PURPOSE OF THE PRODUCTS. BUYER ACKNOWLEDGES THAT IT ALONE HAS DETERMINED THAT THE PRODUCTS WILL SUITABLY MEET THE REQUIREMENTS OF THEIR INTENDED USE.

Omron further disclaims all warranties and responsibility of any type for claims or expenses based on infringement by the Products or otherwise of any intellectual property right.

● Buyer Remedy

Omron's sole obligation hereunder shall be, at Omron's election, to (i) replace (in the form originally shipped with Buyer responsible for labor charges for removal or replacement thereof) the non-complying Product, (ii) repair the non-complying Product, or (iii) repay or credit Buyer an amount equal to the purchase price of the non-complying Product; provided that in no event shall Omron be responsible for warranty, repair, indemnity or any other claims or expenses regarding the Products unless Omron's analysis confirms that the Products were properly handled, stored, installed and maintained and not subject to contamination, abuse, misuse or inappropriate modification. Return of any Products by Buyer must be approved in writing by Omron before shipment. Omron Companies shall not be liable for the suitability or unsuitability or the results from the use of Products in combination with any electrical or electronic components, circuits, system assemblies or any other materials or substances or environments. Any advice, recommendations or information given orally or in writing, are not to be construed as an amendment or addition to the above warranty.

See <http://www.omron.com/global/> or contact your Omron representative for published information.

Limitation on Liability; Etc

OMRON COMPANIES SHALL NOT BE LIABLE FOR SPECIAL, INDIRECT, INCIDENTAL, OR CONSEQUENTIAL DAMAGES, LOSS OF PROFITS OR PRODUCTION OR COMMERCIAL LOSS IN ANY WAY CONNECTED WITH THE PRODUCTS, WHETHER SUCH CLAIM IS BASED IN CONTRACT, WARRANTY, NEGLIGENCE OR STRICT LIABILITY.

Further, in no event shall liability of Omron Companies exceed the individual price of the Product on which liability is asserted.

Application Considerations

Suitability of Use

Omron Companies shall not be responsible for conformity with any standards, codes or regulations which apply to the combination of the Product in the Buyer's application or use of the Product. At Buyer's request, Omron will provide applicable third party certification documents identifying ratings and limitations of use which apply to the Product. This information by itself is not sufficient for a complete determination of the suitability of the Product in combination with the end product, machine, system, or other application or use. Buyer shall be solely responsible for determining appropriateness of the particular Product with respect to Buyer's application, product or system. Buyer shall take application responsibility in all cases.

NEVER USE THE PRODUCT FOR AN APPLICATION INVOLVING SERIOUS RISK TO LIFE OR PROPERTY WITHOUT ENSURING THAT THE SYSTEM AS A WHOLE HAS BEEN DESIGNED TO ADDRESS THE RISKS, AND THAT THE OMRON PRODUCT(S) IS PROPERLY RATED AND INSTALLED FOR THE INTENDED USE WITHIN THE OVERALL EQUIPMENT OR SYSTEM.

Programmable Products

Omron Companies shall not be responsible for the user's programming of a programmable Product, or any consequence thereof.

Disclaimers

Performance Data

Data presented in Omron Company websites, catalogs and other materials is provided as a guide for the user in determining suitability and does not constitute a warranty. It may represent the result of Omron's test conditions, and the user must correlate it to actual application requirements. Actual performance is subject to the Omron's Warranty and Limitations of Liability.

Change in Specifications

Product specifications and accessories may be changed at any time based on improvements and other reasons. It is our practice to change part numbers when published ratings or features are changed, or when significant construction changes are made. However, some specifications of the Product may be changed without any notice. When in doubt, special part numbers may be assigned to fix or establish key specifications for your application. Please consult with your Omron's representative at any time to confirm actual specifications of purchased Product.



Errors and Omissions

Information presented by Omron Companies has been checked and is believed to be accurate; however, no responsibility is assumed for clerical, typographical or proofreading errors or omissions.

Safety Precautions

Definition of Precautionary Information

The following notation is used in this manual to provide precautions required to ensure safe usage of an NX-series Controller. The safety precautions that are provided are extremely important to safety. Always read and heed the information provided in all safety precautions. The following notation is used.

 WARNING	Indicates a potentially hazardous situation which, if not avoided, could result in death or serious injury. Additionally, there may be severe property damage.
 Caution	Indicates a potentially hazardous situation which, if not avoided, may result in minor or moderate injury, or property damage.

Symbols



The circle and slash symbol indicates operations that you must not do. The specific operation is shown in the circle and explained in text. This example indicates prohibiting disassembly.



The triangle symbol indicates precautions (including warnings). The specific operation is shown in the triangle and explained in text. This example indicates a precaution for electric shock.



The triangle symbol indicates precautions (including warnings). The specific operation is shown in the triangle and explained in text. This example indicates a general precaution.



The filled circle symbol indicates operations that you must do. The specific operation is shown in the circle and explained in text. This example shows a general precaution for something that you must do.



The triangle symbol indicates precautions (including warnings). The specific operation is shown in the triangle and explained in text. This example indicates a precaution for high temperatures.

Warnings

WARNING

During Power Supply

Do not touch any of the terminals or terminal blocks while the power is being supplied.
Doing so may result in electric shock.



Do not attempt to take any Unit apart.
In particular, high-voltage parts are present in the Power Supply Unit while power is supplied or immediately after power is turned OFF. Touching any of these parts may result in electric shock. There are sharp parts inside the Unit that may cause injury.



Fail-safe Measures

Provide safety measures in external circuits to ensure safety in the system if an abnormality occurs due to malfunction of the CPU Unit, slaves, or Units or due to other external factors affecting operation. Not doing so may result in serious accidents due to incorrect operation.



Emergency stop circuits, interlock circuits, limit circuits, and similar safety measures must be provided in external control circuits.



The Controller outputs may remain ON or OFF due to deposition or burning of the output relays or destruction of the output transistors. As a countermeasure for such problems, external safety measures must be provided to ensure safe operation of the system.



The CPU Unit will turn OFF all outputs from Digital Output Units in the following cases. The slaves will operate according to the settings in the slaves.

- If an error occurs in the power supply
- If a CPU error or CPU reset occurs
- If a major fault level Controller error occurs
- While the CPU Unit is on standby until RUN mode is entered after the power is turned ON
- If a system initialization error occurs



External safety measures must be provided to ensure safe operation of the system in such cases.

If external power supplies for slaves or other devices are overloaded or short-circuited, the voltage will drop, outputs will turn OFF, and the system may be unable to read inputs. Provide external safety measures in controls with monitoring of external power supply voltage as required so that the system operates safely in such a case.



Unintended outputs may occur when an error occurs in variable memory. As a countermeasure for such problems, external safety measures must be provided to ensure safe operation of the system.



Provide measures in the communications system and user program to ensure safety in the overall system even if errors or malfunctions occur in data link communications or remote I/O communications.



If there is interference in remote I/O communications or if a major fault level error occurs, output status will depend on the products that are used. Confirm the operation that will occur when there is interference in communications or a major fault level error, and implement safety measures. Correctly set all of the settings in the slaves and Units.



The NX-series Controller continues normal operation for a certain period of time when a momentary power interruption occurs. This means that the NX-series Controller may receive incorrect signals from external devices that are also affected by the power interruption. Accordingly, take suitable actions, such as external fail-safe measures and interlock conditions, to monitor the power supply voltage of the external device as required.



You must take fail-safe measures to ensure safety in the event of incorrect, missing, or abnormal signals caused by broken signal lines, momentary power interruptions, or other causes. Not doing so may result in serious accidents due to incorrect operation.



Voltage and Current Inputs

Make sure that the voltages and currents that are input to the slaves and Units are within the specified ranges. Inputting voltages or currents that are outside of the specified ranges may cause accidents or fire.



Downloading

Always confirm safety at the destination before you transfer a user program, configuration data, setup data, or device variables from the Sysmac Studio. The devices or machines may perform unexpected operation regardless of the operating mode of the CPU Unit.



Actual Operation

Check the user program, data, and parameter settings for proper execution before you use them for actual operation.



Cautions

Caution

Application

Do not touch any Unit when power is being supplied or immediately after the power supply is turned OFF. Doing so may result in burn injury.



Wiring

Be sure that all terminal screws and cable connector screws are tightened to the torque specified in the relevant manuals. The loose screws may result in fire or malfunction.



When you connect a computer or other peripheral device to a Controller that has a non-isolated DC Power Supply Unit, either ground the 0-V side of the external power supply or do not ground it at all.

If the peripheral devices are grounded incorrectly, the external power supply may be short-circuited. Never ground the 24-V side of the power supply, as shown in the following figure.

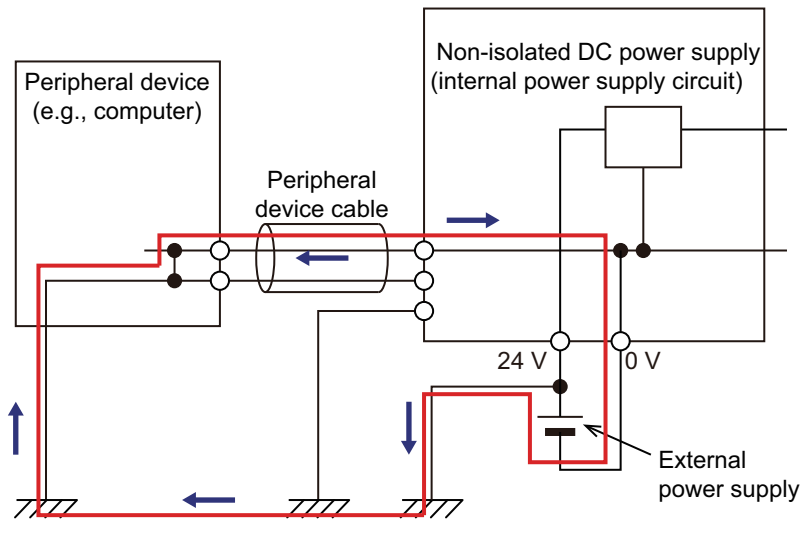

Online Editing

Execute online editing only after confirming that no adverse effects will be caused by deviations in the timing of I/O. If you perform online editing, the task execution time may exceed the task period, I/O may not be refreshed with external devices, input signals may not be read, and output timing may change.



Precautions for Safe Use

Disassembly and Dropping

- Do not attempt to disassemble, repair, or modify any Units. Doing so may result in malfunction or fire.
- Do not drop any Unit or subject it to abnormal vibration or shock. Doing so may result in Unit malfunction or burning.

Mounting

- The sliders on the tops and bottoms of the Power Supply Unit and CPU Unit must be completely locked (until they click into place) after connecting the adjacent Unit connectors.
- Do not apply labels or tape to the Unit. When the Unit is installed or removed, adhesive or scraps may adhere to the pins in the NX bus connector, which may result in malfunctions.
- Do not touch the pins in the NX bus connector on the Unit. Dirt may adhere to the pins in the NX bus connector, which may result in malfunctions.

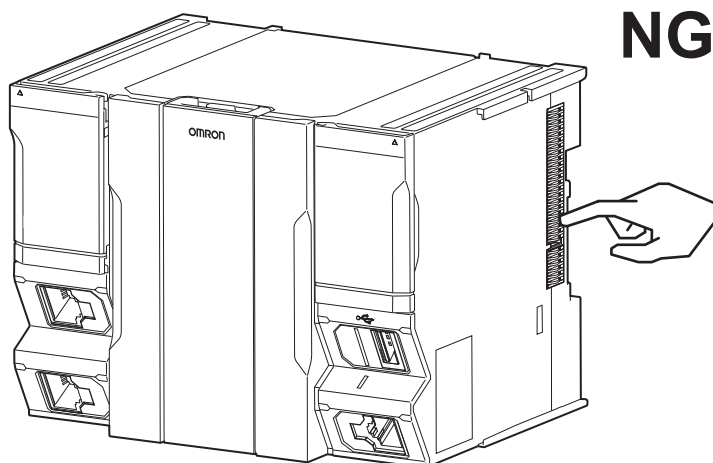

- Do not write on the CPU Unit with ink within the restricted region that is shown in the following figure. Also do not get this area dirty. When the Unit is installed or removed, ink or dirt may adhere to the pins in the NX connector, which may result in malfunctions.

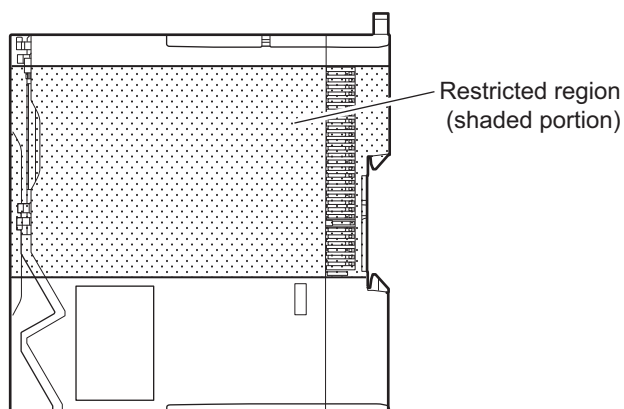

Installation

- Always connect to a ground of 100 Ω or less when installing the Units.

Wiring

- Follow the instructions in this manual to correctly perform wiring. Double-check all wiring and switch settings before turning ON the power supply.
- Use crimp terminals for wiring. Do not connect bare stranded wires directly to terminals.
- Do not pull on the cables or bend the cables beyond their natural limit. Do not place heavy objects on top of the cables or other wiring lines. Doing so may break the cables.
- Mount terminal blocks and connectors only after checking the mounting location carefully.
- Be sure that the terminal blocks, expansion cables, and other items with locking devices are properly locked into place.
- Before you connect a computer to the CPU Unit, disconnect the power supply plug of the computer from the AC outlet. Also, if the computer has an FG terminal, make the connections so that the FG terminal has the same electrical potential as the GR terminal on the Power Supply Unit. A difference in electrical potential between the computer and Controller may cause failure or malfunction.
- If the external power supply to an Output Unit or slave has polarity, connect it with the correct polarity. If the polarity is reversed, current may flow in the reverse direction and damage the connected devices regardless of the operation of the Controller.

Power Supply Design

- Do not exceed the rated supply capacity of the Power Supply Units in the NX-series Controller. The rated supply capacities are given in the *NX-series CPU Unit Hardware User's Manual* (Cat. No. W535). If the capacity is exceeded, operation may stop, malfunctions may occur, or data may not be backed up normally for power interruptions.
- Do not apply voltages or connect loads to the Output Units or slaves in excess of the maximum ratings.
- Surge current occurs when the power supply is turned ON. When selecting fuses or breakers for external circuits, consider the above precaution and allow sufficient margin in shut-off performance. Refer to the relevant manuals for surge current specifications. Refer to the *NX-series CPU Unit Hardware User's Manual* (Cat. No. W535) for surge current specifications.
- If the full dielectric strength voltage is applied or turned OFF using the switch on the tester, the generated impulse voltage may damage the Power Supply Unit. Use the adjustment on the tester to gradually increase and decrease the voltage.
- Apply the voltage between the Power Supply Unit's L1 or L2 terminal and the GR terminal when testing insulation and dielectric strength.
- Do not supply AC power from an inverter or other device with a square-wave output. Internal temperature rise may result in smoking or burning. Always input a sinusoidal wave with the frequency that is given in the *NX-series CPU Unit Hardware User's Manual* (Cat. No. W535).
- Install external breakers and take other safety measures against short-circuiting in external wiring.

Turning ON the Power Supply

- It takes up to approximately 10 to 20 s to enter RUN mode after the power is turned ON. The outputs during this time behave according to the slave or Unit specifications. Use the RUN output on the Power Supply Unit, for example, to implement fail-safe circuits so that external devices do not operate incorrectly.
- Configure the external circuits so that the power supply to the control system turns ON only after the power supply to the Controller has turned ON. If the power supply to the Controller is turned ON after the control power supply, temporary errors may result in incorrect control system signals because the output terminals on Output Units may momentarily turn ON when power supply is turned ON to the Controller.

- If you transfer data from a backup file on an SD Memory Card to the Controller when the power supply is turned ON, properly select the data groups to transfer. If the data for an unintended data group is transferred to the Controller, it may cause the equipment to operate unpredictably.

Turning OFF the Power Supply

- Never turn OFF the power supply to the Controller when the BUSY indicator is flashing. While the BUSY indicator is lit, the user program and settings in the CPU Unit are being backed up in the built-in non-volatile memory. This data will not be backed up correctly if the power supply is turned OFF. Also, a major fault level Controller error will occur the next time you start operation, and operation will stop.
- Do not turn OFF the power supply or remove the SD Memory Card while SD Memory Card access is in progress (i.e., while the SD BUSY indicator flashes). Data may become corrupted, and the Controller will not operate correctly if it uses corrupted data. To remove the SD Memory Card from the CPU Unit while the power supply is ON, press the SD Memory Card power supply switch and wait for the SD BUSY indicator to turn OFF before you remove the SD Memory Card.
- Do not disconnect the cable or turn OFF the power supply to the Controller when downloading data or the user program from Support Software.
- Always turn OFF the power supply to the Controller before you attempt any of the following.
 - a) Mounting or removing the Units
 - b) Assembling the Units
 - c) Setting DIP switches or rotary switches
 - d) Connecting cables or wiring the system
 - e) Connecting or disconnecting the connectors
 - f) Mounting or removing the Fan Unit

The Power Supply Unit may continue to supply power to the rest of the Controller for a few seconds after the power supply turns OFF. The PWR indicator is lit during this time. Confirm that the PWR indicator is not lit before you perform any of the above.

Operation

- Confirm that no adverse effect will occur in the system before you attempt any of the following.
 - a) Changing the operating mode of the CPU Unit (including changing the setting of the Startup Mode)
 - b) Changing the user program or settings
 - c) Changing set values or present values
 - d) Forced refreshing
- After you change any slave or Unit settings, carefully check the safety of the controlled system before you restart the Unit.
- If two different function modules are used together, such as when you use EtherNet/IP and EtherCAT slaves, take suitable measures in the user program and external controls to ensure that safety is maintained in the controlled system if one of the function modules stops. The relevant outputs will behave according to the slave or Unit specifications if a partial fault level error occurs in one of the function modules.
- Always confirm safety at the connected equipment before you reset Controller errors with an event level of partial fault or higher for the EtherCAT Master Function Module.

When the error is reset, all slaves that were in any state other than Operational state due to a Controller error with an event level of partial fault or higher (in which outputs are disabled) will go to Operational state and the outputs will be enabled.

Before you reset all errors or restart a slave, confirm that no Controller errors with an event level of partial fault have occurred for the EtherCAT Master Function Module.

Battery Backup

- The user program and initial values for the variables are stored in non-volatile memory in the CPU Unit. The present values of variables with the Retain attribute are backed up by a Battery. If the Battery is not connected or the Battery is exhausted, the CPU Unit detects a Battery-backup Memory Check Error. If that error is detected, variables with a Retain attribute are set to their initial values. Perform thorough verifications and provide sufficient measures to ensure that the devices perform safe operation for the initial values of the variables with Retain attributes and the resulting operation.
- The absolute encoder home offsets are backed up by a Battery. If the CPU Unit detects a low battery voltage or the absence of a mounted battery when the power supply to the Controller is turned ON, the absolute encoder home offsets are cleared to zeros and an Encoder Home Offset Read Error occurs. Reset the error and perform homing to define home. If you do not define home, unintended operation of the controlled system may occur.

Debugging

- Forced refreshing ignores the results of user program execution and refreshes I/O with the specified values. If forced refreshing is used for inputs for which I/O refreshing is not supported, the inputs will first take the specified values, but they will then be overwritten by the user program. This operation differs from the force-set/reset functionality of the CJ-series PLCs.
- You cannot upload or download information for forced refreshing with the Sysmac Studio. After downloading data that contains forced refreshing, change to RUN mode and then use the Sysmac Studio to perform the operation for forced refreshing. Depending on the difference in the forced status, the control system may operate unexpectedly.
- Do not specify the same address for the AT specification for more than one variable. Doing so would allow the same entity to be accessed with different variable names, which would make the user program more difficult to understand and possibly cause programming mistakes.

General Communications

- When you use data link communications, check the error information that is given in `_ErrSta` (Controller Error Status) to make sure that no error has occurred in the source device. Create a user program that uses reception data only when there is no error in the source device. If there is an error in the source device, the data for the data link may contain incorrect values.
- Unexpected operation may result if inappropriate data link tables are set. Even if appropriate data link tables have been set, confirm that the controlled system will not be adversely affected before you transfer the data link tables. The data links start automatically after the data link tables are transferred.

EtherNet/IP Communications

- Make sure that the communications distance, number of nodes connected, and method of connection for EtherNet/IP are within specifications. Do not connect EtherNet/IP communications to EtherCAT or other networks. An overload may cause the network to fail or malfunction.
- All related EtherNet/IP nodes are reset when you transfer settings for the built-in EtherNet/IP port (including IP addresses and tag data links settings). The settings can only be enabled after the reset. Confirm that the system will not be adversely affected by resetting nodes before you transfer the settings.
- If EtherNet/IP tag data links (cyclic communications) are used with a repeating hub, the communications load on the network will increase. This will increase collisions and may prevent stable communications. Do not use repeating hubs on networks where tag data links are used. Use an Ethernet switch instead.
- When you use two EtherNet/IP networks separately, provide separate hubs to connect nodes in each network.

- Be careful not to mix nodes that belong different EtherNet/IP networks when you connect them.

EtherCAT Communications

- Make sure that the communications distance, number of nodes connected, and method of connection for EtherCAT are within specifications.
Do not connect EtherCAT communications to EtherNet/IP, a standard in-house LAN, or other networks. An overload may cause the network to fail or malfunction.
- Malfunctions or unexpected operation may occur for some combinations of EtherCAT revisions of the master and slaves. If you disable the revision check in the network settings, use the Sysmac Studio to check the slave revision settings in the master and the actual slave revisions, and then make sure that functionality is compatible in the slave manuals or other references. You can check the actual slave revisions from the Sysmac Studio or on slave nameplates.
- After you transfer the user program, the CPU Unit is restarted and communications with the EtherCAT slaves are cut off. During that period, the slave outputs behave according to the slave specifications. The time that communications are cut off depends on the EtherCAT network configuration. Before you transfer the user program, confirm that the system will not be adversely affected.
- If the Fail-soft Operation parameter is set to stop operation, process data communications will stop for all slaves when an EtherCAT communications error is detected in a slave. At that time, the Servo Drive will operate according to the Servo Drive specifications. For this reason, if Servo Drives are connected, the Servos for all axes will be turned OFF. Make sure that the Fail-soft Operation parameter setting results in safe operation when a device error occurs.
- EtherCAT communications are not always established immediately after the power supply is turned ON. Use the system-defined variables in the user program to confirm that communications are established before attempting control operations.
- If noise occurs or an EtherCAT slave is disconnected from the network, any current communications frames may be lost. If frames are lost, slave I/O data is not communicated, and unintended operation may occur. The slave outputs will behave according to the slave specifications. If a noise countermeasure or slave replacement is required, perform the following processing.
 - a) Program the Input Data Invalid system-defined variable as an interlock condition in the user program.
 - b) Set the PDO communications timeout detection count setting in the EtherCAT master to at least 2. Refer to the *NJ/NX-series CPU Unit Built-in EtherCAT Port User's Manual* (Cat. No. W505) for details.
- When an EtherCAT slave is disconnected or disabled, communications will stop and control of the outputs will be lost not only for the disconnected slave, but for all slaves connected after it. Confirm that the system will not be adversely affected before you disconnect or disable a slave.
- I/O data communications of NX bus are not always established immediately after the power supply is turned ON. Use the system-defined variables and the EtherCAT Coupler Unit device variables in the user program to confirm that I/O data communications are established before attempting control operations.
- You cannot use standard Ethernet hubs or repeater hubs with EtherCAT communications. If you use one of these, a major fault level error or other error may occur.

Motion Control

- Confirm the axis number carefully before you perform an MC Test Run.
- The motor is stopped if communications are interrupted between the Sysmac Studio and the CPU Unit during an MC Test Run. Connect the communications cable between the computer and CPU Unit securely and confirm that the system will not be adversely affected before you perform an MC Test Run.
- Always execute the Save Cam Table instruction if you change any of the cam data from the user program in the CPU Unit or from the Sysmac Studio. If the cam data is not saved, the previous condition will be restored when the power is turned ON again, possibly causing unexpected machine operation.
- The positive drive prohibit input (POT), negative drive prohibit input (NOT), and home proximity input (DEC) of the Servo Drive are used by the MC Function Module as the positive limit input, negative limit input, and home proximity input. Make sure that the signal widths for all of these input signals are longer than the control period of the MC Function Module. If the input signal widths are shorter than the control period, the MC Function Module may not be able to detect the input signals, resulting in incorrect operation.
- If you make any changes in the Detailed Settings Area of the Axis Basic Settings Display of the Sysmac Studio, make sure that the devices or machines perform the expected operation before you start actual operation.

If the relationship between the functions of the Motion Control Function Module and the EtherCAT slave process data that is assigned to the axes is not correct, the devices or machines may perform unexpected operation.

- Always use the axis at a constant velocity for the MC_DigitalCamSwitch (Enable Digital Cam Switch) instruction.

If you set the Count Mode to Rotary Mode, the following operation will occur if you use *OnCompensation* or *OffCompensation* and the axis velocity changes abruptly.

- If the value of *OnCompensation* or *OffCompensation* is equivalent to the time for half a rotation or more, *InOperation* will be FALSE.
- If the value of *OnCompensation* results in exceeding *LastOnPosition*, the output timing will be unstable.

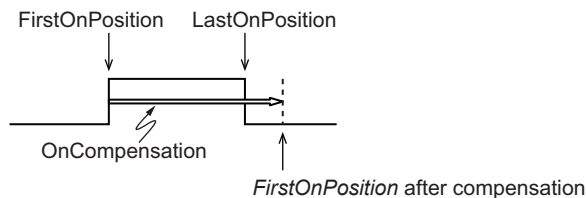

- If the value of *OffCompensation* results in exceeding *FirstOnPosition*, the output timing will be unstable.

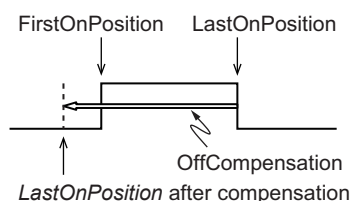

- Use the NX_AryDOutTimeStamp (Write Digital Output Array with Specified Time Stamp) instruction only after you confirm that *InOperation* from the MC_DigitalCamSwitch (Enable Digital Cam Switch) instruction is TRUE.

Restoring Data

- You cannot back up, restore, or compare some or all of the settings for certain slaves and Units. Also, you cannot back up, restore, or compare data for disabled slaves or Units. After you restore data, sufficiently confirm that operation is correct before you start actual operation.
- The absolute encoder home offsets are backed up with a Battery in the CPU Unit as absolute encoder information. If any of the following conditions is met, clear the absolute encoder home offsets from the list of data items to restore, and then restore the data. Then, define the absolute encoder home again. If you do not define home, unintended operation of the controlled system may occur.
 - a) The Servomotor or Servo Drive was changed since the data was backed up.
 - b) The absolute encoder was set up after the data was backed up.
 - c) The absolute data for the absolute encoder was lost.

Battery Replacement

- The Battery may leak, rupture, heat, or ignite. Never short-circuit, charge, disassemble, heat, or incinerate the Battery or subject it to strong shock.
- Dispose of any Battery that has been dropped on the floor or otherwise subjected to excessive shock. Batteries that have been subjected to shock may leak if they are used.
- Apply power for at least five minutes before changing the Battery. Install a new Battery within five minutes (at 25°C) of turning OFF the power supply. If power is not supplied for at least 5 minutes, the saved data may be lost.
- We recommend replacing the Battery with the power turned OFF to prevent the CPU Unit's sensitive internal components from being damaged by static electricity and to prevent malfunctions. The Battery can be replaced without turning OFF the power supply. To do so, always touch a grounded piece of metal to discharge static electricity from your body before you start the procedure. After you replace the Battery, connect the Sysmac Studio and clear the Low Battery Voltage error.

Fan Unit Replacement

- Do not touch the heatsink inside the CPU Unit immediately after turning OFF the power supply. Doing so may result in burn injury.

Unit Replacement

- Make sure that the required data, including the user program, configurations, settings, and variables, is transferred to a CPU Unit that was replaced and to externally connected devices before restarting operation.
Be sure to include the tag data link settings and routing tables, which are stored in the CPU Unit.
- The absolute encoder home offsets are backed up with a Battery in the CPU Unit as absolute encoder information. When you change the combination of the CPU Unit and Servomotor, e.g., when you add or replace a Servomotor, define the absolute encoder home again.

Disposal

- Dispose of the product and Batteries according to local ordinances as they apply.



廢電池請回收

- The following information must be displayed for all products that contain primary lithium batteries with a perchlorate content of 6 ppb or higher when shipped to or transported through the State of California, USA.
Perchlorate Material - special handling may apply.
See www.dtsc.ca.gov/hazardouswaste/perchlorate.
- The CPU Unit contains a primary lithium battery with a perchlorate content of 6 ppb or higher. Place the above information on the individual boxes and shipping boxes when shipping finished products that contain a CPU Unit to the State of California, USA.

Precautions for Correct Use

Storage and Installation

- Follow the instructions in this manual to correctly perform installation.
- Do not operate or store the Controller in the following locations. Operation may stop or malfunctions may occur.
 - a) Locations subject to direct sunlight
 - b) Locations subject to temperatures or humidity outside the range specified in the specifications
 - c) Locations subject to condensation as the result of severe changes in temperature
 - d) Locations subject to corrosive or flammable gases
 - e) Locations subject to dust (especially iron dust) or salts
 - f) Locations subject to exposure to water, oil, or chemicals
 - g) Locations subject to shock or vibration
- Take appropriate and sufficient countermeasures when installing the Controller in the following locations.
 - a) Locations subject to strong, high-frequency noise
 - b) Locations subject to static electricity or other forms of noise
 - c) Locations subject to strong electromagnetic fields
 - d) Locations subject to possible exposure to radioactivity
 - e) Locations close to power lines
- Before touching a Unit, be sure to first touch a grounded metallic object in order to discharge any static build-up.
- Install the Controller away from sources of heat and ensure proper ventilation. Not doing so may result in malfunction, in operation stopping, or in burning.

Mounting

- When you install the Unit, be careful not to touch or bump the pins in the NX bus connector.
- When you handle the Unit, be careful not to apply stress to the pins in the NX bus connector. If the Unit is installed and the power supply is turned ON when the pins in the NX bus connector are deformed, contact failure may cause malfunctions.
- Always mount an End Cover to the end of the CPU Rack to protect the last Unit on the CPU Rack. Not mounting the End Cover may result in malfunction or failure of the CPU Unit.
- After you mount the Unit, always secure it with End Plates at both sides. If you do not secure it, the Unit may be damaged or malfunction.
- If you use DIN Track Insulation Spacers to install a CPU Rack, the height will be increased by approximately 10 mm. Make sure that the CPU Rack and connecting cables do not come into contact with other devices.

Wiring

- Do not allow foreign matter to enter the openings in the Unit. Doing so may result in Unit burning, electric shock, or failure.
- Do not allow wire clippings, shavings, or other foreign material to enter any Unit. Otherwise, Unit burning, failure, or malfunction may occur. Cover the Units or take other suitable countermeasures, especially during wiring work.

- For EtherCAT and EtherNet/IP, use the connection methods and cables that are specified in the *NJ/NX-series CPU Unit Built-in EtherCAT Port User's Manual* (Cat. No. W505) and the *NJ/NX-series CPU Unit Built-in EtherNet/IP Port User's Manual* (Cat. No. W506). Otherwise, communications may be faulty.
- Use the rated power supply voltage for the Power Supply Units. Take appropriate measures to ensure that the specified power with the rated voltage and frequency is supplied in places where the power supply is unstable.
- Make sure that the current capacity of the wire is sufficient. Otherwise, excessive heat may be generated. When cross-wiring terminals, the total current for all the terminals will flow in the wire. When wiring cross-overs, make sure that the current capacity of each of the wires is not exceeded.
- Do not touch the terminals on the Power Supply Unit immediately after turning OFF the power supply. Residual voltage may cause electrical shock.
- If you use reed switches for the input contacts for AC Input Units, use switches with a current capacity of 1 A or greater.
If the capacity of the reed switches is too low, surge current may fuse the contacts.

Error Processing

- In applications that use the results of instructions that read the error status, consider the affect on the system when errors are detected and program error processing accordingly. For example, even the detection of a minor error, such as Battery replacement during operation, can affect the system depending on how the user program is written.
- If you change the event level of a Controller error, the output status when the error occurs may also change. Confirm safety before you change an event level.

Restoring and Automatically Transferring Data

- When you edit the restore command file or the automatic transfer command file, do not change anything in the file except for the “yes” and “no” specifications for the selectable data groups. If you change anything else in the file, the Controller may perform unexpected operation when you restore or automatically transfer the data.

Replacing Slaves and Units

- If you replace a slave or Unit, refer to the operation manual for the slave or Unit for information on the data required for individual slaves or Units and redo the necessary settings.

Task Settings

- If a Task Period Exceeded error occurs, shorten the programs to fit in the task period or increase the setting of the task period.

Motion Control

- Use the system-defined variable in the user program to confirm that EtherCAT communications are established before you attempt to execute motion control instructions. Motion control instructions are not executed normally if EtherCAT communications are not established.
- Use the system-defined variables to monitor for errors in communications with the slaves that are controlled by the motion control function module. Motion control instructions are not executed normally if an error occur in slave communications.
- Before you start an MC Test Run, make sure that the operation parameters are set correctly.
- Do not download motion control settings during an MC Test Run.

EtherCAT Communications

- If you need to disconnect the cable from an EtherCAT slave during operation, first disconnect the software connection to the EtherCAT slave or disable the EtherCAT slave and all of the EtherCAT slaves that are connected after it.
- Set the Servo Drives to stop operation if an error occurs in EtherCAT communications between the Controller and a Servo Drive.
- Make sure that all of the slaves to be restored are participating in the network before you reset a Network Configuration Verification Error, Process Data Communications Error, or Link OFF Error in the EtherCAT Master Function Module. If any slave is not participating when any of these errors is reset, the EtherCAT Master Function Module may access slave with a different node address than the specified node address or the error may not be reset correctly.
- Always use the specified EtherCAT slave cables. If you use any other cable, the EtherCAT master or the EtherCAT slaves may detect an error and one of the following may occur.
 - a) Continuous refreshing of process data communications will not be possible.
 - b) Continuous refreshing of process data communications will not end during the set cycle.

Battery Replacement

- Be sure to install a replacement Battery within two years of the production date shown on the Battery label.
- Turn ON the power after replacing the Battery for a CPU Unit that has been unused for a long time. Leaving the CPU Unit unused again without turning ON the power even once after the Battery is replaced may result in a shorter Battery life.
- When you replace the Battery, use the CJ1W-BAT01 Battery Set.

SD Memory Cards

- Insert the SD Memory Card all the way.
- Do not turn OFF the power supply to the Controller during SD Memory Card access. The files may be corrupted.
If there is a corrupted file in the SD Memory Card, the file is automatically deleted by the restoration function when the power supply is turned ON.
- If you use an OMRON SD Memory Card, the end of the life of the SD Memory Card can be detected in the following ways.
 - a) *_Card1Deteriorated* (SD Memory Card Life Warning Flag) system-defined variable
 - b) SD Memory Card Life Exceeded event in the event log

When the end of the life is detected in any of the above ways, replace the SD Memory Card.

Online Editing

- When performing online editing, the CPU Unit saves a program updated by the online editing to built-in non-volatile memory. Sysmac Studio shows a message that it is in a backup operation. Do not turn OFF the power supply to the Controller while this message is displayed. If the power supply to the Controller is turned OFF, a Controller error will occur when the power supply is turned ON next time.

Regulations and Standards

Conformance to EC Directives

Applicable Directives

- EMC Directives
- Low Voltage Directive

Concepts

● EMC Directives

OMRON devices that comply with EC Directives also conform to the related EMC standards so that they can be more easily built into other devices or the overall machine. The actual products have been checked for conformity to EMC standards^{*1}

Whether the products conform to the standards in the system used by the customer, however, must be checked by the customer. EMC-related performance of the OMRON devices that comply with EC Directives will vary depending on the configuration, wiring, and other conditions of the equipment or control panel on which the OMRON devices are installed. The customer must, therefore, perform the final check to confirm that devices and the overall machine conform to EMC standards.

*1. Applicable EMC (Electromagnetic Compatibility) standards are as follows:

EMS (Electromagnetic Susceptibility): EN 61131-2

EMI (Electromagnetic Interference): EN 61131-2 (Radiated emission: 10-m regulations).

● Low Voltage Directive

Always ensure that devices operating at voltages of 50 to 1,000 VAC and 75 to 1,500 VDC meet the required safety standards. The applicable directive is EN 61131-2.

● Conformance to EC Directives

The NX-series Units comply with EC Directives. To ensure that the machine or device in which the NX-series Units are used complies with EC Directives, the following precautions must be observed.

- The NX-series Units must be installed within a control panel.
- The SELV requirements must be satisfied for the DC power supplies connected to the DC Power Supply Units of NX-series Units. EMC standard compliance was confirmed for the OMRON S8VS-18024 DC Power Supplies.
- NX-series Units that comply with EC Directives also conform to the Common Emission Standard. Radiated emission characteristics (10-m regulations) may vary depending on the configuration of the control panel used, other devices connected to the control panel, wiring, and other conditions. You must therefore confirm that the overall machine or equipment in which the NX-series Units are used complies with EC Directives.
- This is a Class A product (for industrial environments). In a residential environment, it may cause radio interference. If radio interference occurs, the user may be required to take appropriate measures.

Conformance to UL and CSA Standards

Some NX-series products comply with UL and CSA standards.

If you use a product that complies with UL or CSA standards and must apply those standards to your machinery or devices, refer to the *Instruction Sheet* that is provided with the product. The *Instruction Sheet* provides the application conditions for complying with the standards.

Conformance to KC Standards

Observe the following precaution if you use NX-series Units in Korea.

A 급 기기 (업무용 방송통신기자재)
이 기기는 업무용(A 급) 전자파적합기기로서 판매자
또는 사용자는 이 점을 주의하시기 바라며, 가정외의
지역에서 사용하는 것을 목적으로 합니다.

Class A Device (Broadcasting Communications Device for Office Use)

This device obtained EMC registration for office use (Class A), and it is intended to be used in places other than homes.

Sellers and/or users need to take note of this.

Software Licenses and Copyrights

This product incorporates certain third party software. The license and copyright information associated with this software is available at http://www.fa.omron.co.jp/nj_info_e/.

Versions

Unit versions are used to manage the hardware and software in NX-series Units and EtherCAT slaves.

The unit version is updated each time there is a change in hardware or software specifications. Even when two Units or EtherCAT slaves have the same model number, they will have functional or performance differences if they have different unit versions.

Checking Versions

You can check versions in the ID information indications on the product or with the Sysmac Studio.

Checking Unit Versions on ID Information Indications

The unit version is given on the ID information indication on the side of the product.

The ID information on an NX-series NX701-□□□□ CPU Unit is shown below.

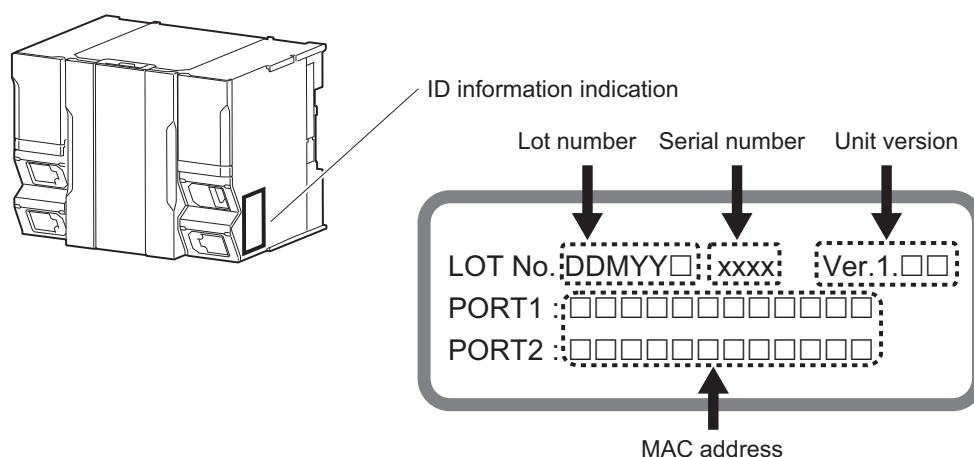

Checking Unit Versions with the Sysmac Studio

● Checking the Unit Version of a Unit

You can use the Production Information while the Sysmac Studio is online to check the unit version of a Unit. You can do this only for the CPU Unit.

Use the following procedure to check the unit version.

- 1** Right-click **CPU Rack** under **Configurations and Setup - CPU/Expansion Racks** in the Multi-view Explorer and select **Production Information**.

The Production Information Dialog Box is displayed.

- Click the **Show Detail** or **Show Outline** Button at the lower right of the Production Information Dialog Box.

The view will change between the production information details and outline.

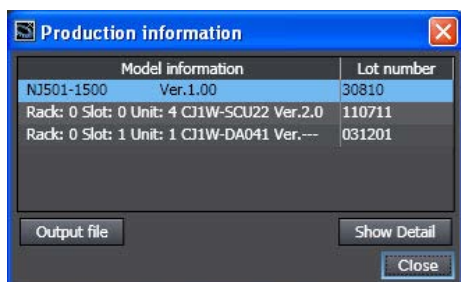

Outline View

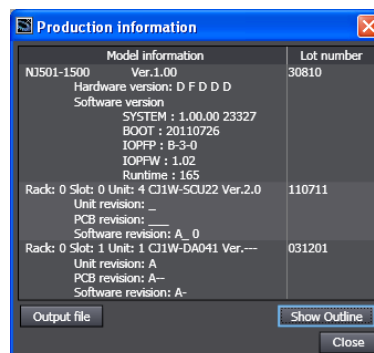

Detail View

The information that is displayed is different for the Outline View and Detail View. The Detail View displays the unit version, hardware version, and software versions. The Outline View displays only the unit version.

● Checking the Unit Version of an EtherCAT Slave

You can use the Production Information while the Sysmac Studio is online to check the unit version of an EtherCAT slave. Use the following procedure to check the unit version.

- Double-click **EtherCAT** under **Configurations and Setup** in the Multiview Explorer. Or, right-click **EtherCAT** under **Configurations and Setup** and select **Edit** from the menu. The EtherCAT Tab Page is displayed for the Controller Configurations and Setup Layer.
- Right-click the master on the EtherCAT Tab Page and select **Display Production Information**. The Production Information Dialog Box is displayed. The unit version is displayed after “Rev.”

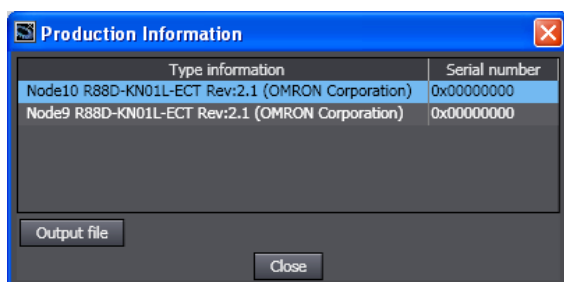

Unit Versions of CPU Units and Sysmac Studio Versions

The functions that are supported depend on the unit version of the NX-series CPU Unit. The version of Sysmac Studio that supports the functions that were added for an upgrade is also required to use those functions.

Refer to *A-3 Version Information* on page A-6 for the relationship between the unit versions of the CPU Units and the Sysmac Studio versions, and for the functions that are supported by each unit version.

Related Manuals

The following manuals are related. Use these manuals for reference.

Manual name	Cat. No.	Model numbers	Application	Description
NX-series CPU Unit Hardware User's Manual	W535	NX701-□□□□	Learning the basic specifications of the NX-series CPU Units, including introductory information, designing, installation, and maintenance. Mainly hardware information is provided.	An introduction to the entire NX-series system is provided along with the following information on a Controller built with a CPU Unit. <ul style="list-style-type: none"> • Features and system configuration • Introduction • Part names and functions • General specifications • Installation and wiring • Maintenance and inspection Use this manual together with the <i>NJ/NX-series CPU Unit Software User's Manual</i> (Cat. No. W501).
NJ/NX-series CPU Unit Software User's Manual	W501	NX701-□□□□ NJ501-□□□□ NJ301-□□□□ NJ101-□□□□	Learning how to program and set up an NJ/NX-series CPU Unit. Mainly software information is provided.	The following information is provided on a Controller built with an NJ/NX-series CPU Unit. <ul style="list-style-type: none"> • CPU Unit operation • CPU Unit features • Initial settings • Programming based on IEC 61131-3 language specifications Use this manual together with the <i>NX-series CPU Unit Hardware User's Manual</i> (Cat. No. W535).
NJ/NX-series Instructions Reference Manual	W502	NX701-□□□□ NJ501-□□□□ NJ301-□□□□ NJ101-□□□□	Learning detailed specifications on the basic instructions of an NJ/NX-series CPU Unit.	The instructions in the instruction set (IEC 61131-3 specifications) are described. When programming, use this manual together with the <i>NX-series CPU Unit Hardware User's Manual</i> (Cat. No. W535) and <i>NJ/NX-series CPU Unit Software User's Manual</i> (Cat. No. W501).
NJ/NX-series CPU Unit Motion Control User's Manual	W507	NX701-□□□□ NJ501-□□□□ NJ301-□□□□ NJ101-□□□□	Learning about motion control settings and programming concepts.	The settings and operation of the CPU Unit and programming concepts for motion control are described. When programming, use this manual together with the <i>NX-series CPU Unit Hardware User's Manual</i> (Cat. No. W535) and <i>NJ/NX-series CPU Unit Software User's Manual</i> (Cat. No. W501).

Manual name	Cat. No.	Model numbers	Application	Description
NJ/NX-series Motion Control Instruc- tions Reference Manual	W508	NX701-□□□□ NJ501-□□□□ NJ301-□□□□ NJ101-□□□□	Learning about the specifications of the motion control instructions.	The motion control instructions are described. When programming, use this manual together with the <i>NX-series CPU Unit Hardware User's Manual</i> (Cat. No. W535), <i>NJ/NX-series CPU Unit Software User's Manual</i> (Cat. No. W501) and <i>NJ/NX-series CPU Unit Motion Control User's Manual</i> (Cat. No. W507).
NJ/NX-series CPU Unit Built-in Ether- CAT® Port User's Manual	W505	NX701-□□□□ NJ501-□□□□ NJ301-□□□□ NJ101-□□□□	Using the built-in EtherCAT port on an NJ/NX-series CPU Unit.	Information on the built-in EtherCAT port is provided. This manual provides an introduction and provides information on the configuration, features, and setup. Use this manual together with the <i>NX-series CPU Unit Hardware User's Manual</i> (Cat. No. W535) and <i>NJ/NX-series CPU Unit Software User's Manual</i> (Cat. No. W501).
NJ/NX-series CPU Unit Built-in EtherNet/IP™ port User's Manual	W506	NX701-□□□□ NJ501-□□□□ NJ301-□□□□ NJ101-□□□□	Using the built-in EtherNet/IP port on an NJ/NX-series CPU Unit.	Information on the built-in EtherNet/IP port is provided. Information is provided on the basic setup, tag data links, and other features. Use this manual together with the <i>NX-series CPU Unit Hardware User's Manual</i> (Cat. No. W535) and <i>NJ/NX-series CPU Unit Software User's Manual</i> (Cat. No. W501).
NJ/NX-series Troubleshooting Manual	W503	NX701-□□□□ NJ501-□□□□ NJ301-□□□□ NJ101-□□□□	Learning about the errors that may be detected in an NJ/NX-series Controller.	Describes concepts on managing errors that may be detected in an NJ/NX-series Controller and information on individual errors. Use this manual together with the <i>NX-series CPU Unit Hardware User's Manual</i> (Cat. No. W535) and <i>NJ/NX-series CPU Unit Software User's Manual</i> (Cat. No. W501).
Sysmac Studio Version 1 Operation Manual	W504	SYSMAC- SE2□□□	Learning about the operating procedures and functions of the Sysmac Studio.	Describes the operating procedures of the Sysmac Studio.
NX-series EtherCAT® Coupler Unit User's Manual	W519	NX-ECC20□	Learning how to use an NX-series EtherCAT Coupler Unit and EtherCAT Slave Terminals	The following items are described: the overall system and configuration methods of an EtherCAT Slave Terminal (which consists of an NX-series EtherCAT Coupler Unit and NX Units), and information on hardware, setup, and functions to set up, control, and monitor NX Units through EtherCAT.
NX-series Data Reference Manual	W525	NX-□□□□□□	Referencing lists of the data that is required to configure systems with NX-series Units	Lists of the power consumptions, weights, and other NX Unit data that is required to configure systems with NX-series Units are provided.

Manual name	Cat. No.	Model numbers	Application	Description
NX-series Digital I/O Units User's Manual	W521	NX-ID□□□□ NX-IA□□□□ NX-OC□□□□ NX-OD□□□□ NX-MD□□□□	Learning how to use NX-series Digital I/O Units	The hardware, setup methods, and functions of the NX-series Digital I/O Units are described.
NX-series Analog I/O Units User's Manual	W522	NX-AD□□□□ NX-DA□□□□ NX-TS□□□□	Learning how to use NX-series Analog I/O Units and Temperature Input Units	The hardware, setup methods, and functions of the NX-series Analog I/O Units and Temperature Input Units are described.
NX-series System Units User's Manual	W523	NX-PD1□□□ NX-PF0□□□ NX-PC0□□□ NX-TBX01	Learning how to use NX-series System Units	The hardware and functions of the NX-series System Units are described.
NX-series Position Interface Units User's Manual	W524	NX-EC0□□□ NX-ECS□□□ NX-PG0□□□	Learning how to use NX-series Position Interface Units	The hardware, setup methods, and functions of the NX-series Incremental Encoder Input Units, SSI Input Units, and Pulse Output Unit are described.
NX-series Safety Control Unit User's Manual	Z930	NX-SL□□□□ NX-SI□□□□ NX-SO□□□□	Learning how to use NX-series Safety Control Units	The hardware, setup methods, and functions of the NX-series Safety Control Unit are described.
NX-series Safety Control Unit Instructions Reference Manual	Z931	NX-SL□□□□	Learning about the specifications of instructions for the Safety CPU Unit.	The instructions for the Safety CPU Unit are described. When programming, use this manual together with the <i>NX-series Safety Control Unit User's Manual</i> (Cat. No. Z930).
NA-series Programmable Terminal Software User's Manual	V118	NA5-□W□□□□	Learning about NA-series PT pages and object functions.	Describes the pages and object functions of the NA-series Programmable Terminals.
NS-series Programmable Terminals Programming Manual	V073	NS15-□□□□□ NS12-□□□□□ NS10-□□□□□ NS8-□□□□□ NS5-□□□□□	Learning how to use the NS-series Programmable Terminals.	Describes the setup methods, functions, etc. of the NS-series Programmable Terminals.

Terminology

Term	Description
absolute encoder home offsets	This data is used to restore in the CPU Unit the actual position of a Servo Drive with an absolute encoder. The offset is the difference between the command position after homing and the absolute data that is read from the absolute encoder.
array specification	One of the variable specifications. An array variable contains multiple elements of the same data type. The elements in the array are specified by serial numbers called subscripts that start from the beginning of the array.
AT	One of the attributes of a variable. This attribute allows the user to specify what is assigned to a variable. An I/O port or an address in memory used for CJ-series Units can be specified.
axes groups	A functional unit that groups together axes within the Motion Control Function Module.
Axes Group Variable	A system-defined variable that is defined as a structure and provides status information and some of the axes parameters for an individual axes group. An Axes Group Variable is used to specify an axes group for motion control instructions and to monitor the command interpolation velocity, error information, and other information for the axes group.
axis	A functional unit within the Motion Control Function Module. An axis is assigned to the drive mechanism in an external Servo Drive or the sensing mechanism in an external Encoder Input Slave Unit.
Axis Variable	A system-defined variable that is defined as a structure and provides status information and some of the axis parameters for an individual axis. An Axis Variable is used to specify an axis for motion control instructions and to monitor the command position, error information, and other information for the axis.
basic data type	Any of the data types that are defined by IEC 61131-3. They include Boolean, bit string, integer, real, duration, date, time of day, date and time, and text string data types. “Basic data type” is used as opposed to derivative data types, which are defined by the user.
cam data variable	A variable that represents the cam data as a structure array. A cam data variable is an array structure that consists of phases and displacements.
CJ-series Unit	Any of the CJ-series Units that can be used with an NJ-series Controller.
Communications Coupler Unit	The generic name of an interface unit for remote I/O communications on a network between NX Units and a host network master. For example, an EtherCAT Coupler Unit is a Communications Coupler Unit for an EtherCAT network.
Constant	One of the attributes of a variable. If you specify the Constant attribute for a variable, the value of the variable cannot be written by any instructions, ST operators, or CIP message communications.
Controller	The range of devices that are directly controlled by the CPU Unit. In the NX-series System, the Controller includes the CPU Rack and EtherCAT slaves (including general-purpose slaves and Servo Drives). In the NJ-series System, the Controller includes the CPU Rack, Expansion Racks, and EtherCAT slaves (including general-purpose slaves and Servo Drives).
Controller error	Errors that are defined by the NJ/NX-series System. “Controller error” is a collective term for major fault level, partial fault level, minor fault level, and observation Controller events.
Controller event	One of the events in the NJ/NX-series System. Controller events are errors and information that are defined by the system for user notification. A Controller event occurs when the system detects a factor that is defined as a Controller event.
Controller information	Information that is defined by the NJ/NX-series System that is not an error. It represents an information Controller event.

Term	Description
CPU Unit	The Unit that serves as the center of control for a Machine Automation Controller. The CPU Unit executes tasks, refreshes I/O for other Units and slaves, etc. The NJ/NX-series CPU Units include NX701-□□□□, NJ501-□□□□, and NJ301-□□□□.
derivative data type	A data type that is defined by the user. Structures, unions, and enumerations are derivative data types.
device variable	A variable that is used to access a specific device through an I/O port.
download	To transfer data from the Sysmac Studio to the Controller with the synchronization operation of the Sysmac Studio.
edge	One of the attributes of a variable. This attribute makes a BOOL variable pass TRUE to a function block when the variable changes from FALSE to TRUE or when it changes from TRUE to FALSE.
enumeration	One of the derivative data types. This data type takes one item from a prepared name list of enumerators as its value.
enumerator	One of the values that an enumeration can take expressed as a character string. The value of an enumeration is one of the enumerators.
EtherCAT Master Function Module	One of the function modules. This function module controls the EtherCAT slaves as the EtherCAT master.
EtherNet/IP Function Module	One of the function modules. This function module controls the built-in EtherNet/IP port.
event log	A function that recognizes and records errors and other events.
Event Setup	Settings that define user-defined errors and user-defined information.
event task	A task that executes a user program only once when the task execution conditions are met.
FB	An acronym for “function block.”
forced refreshing	Forcing the refreshing of an input from an external device or an output to an external device, e.g., when the user debugs a program. Addresses that are subject to forced refreshing can still be overwritten from the user program.
FUN	An abbreviation for “function.”
function	A POU that is used to create an object that determines a unique output for the same input, such as for data processing.
function block	A POU that is used to create an object that can have a different output for the same input, such as for a timer or counter.
function module	One of the functional units of the software configuration of the CPU Unit.
general-purpose slave	Any of the EtherCAT slaves that cannot be assigned to an axis.
global variable	A variable that can be read or written from all POUs (programs, functions, and function blocks).
I/O map settings	Settings that assign variables to I/O ports. Assignment information between I/O ports and variables.
I/O port	A logical interface that is used by the CPU Unit to exchange data with an external device (slave or Unit).
I/O refreshing	Cyclic data exchange with external devices that is performed with predetermined memory addresses.
information	One of the event levels for Controller events or user-defined events. These are not errors, but appear in the event log to notify the user of specific information.
Initial Value	One of the attributes of a variable. The variable is set to the initial value in the following situations. <ul style="list-style-type: none"> • When power is turned ON • When the CPU Unit changes to RUN mode • When you specify to initialize the values when the user program is transferred • When a major fault level Controller error occurs
inline ST	ST programming that is included within a ladder diagram program.

Term	Description
instruction	The smallest unit of the processing elements that are provided by OMRON for use in POU algorithms. There are ladder diagram instructions (program inputs and outputs), function instructions, function block instructions, and ST statements.
literal	A constant expression that is used in a user program.
local variable	A variable that can be accessed only from inside the POU in which it is defined. "Local variable" is used as opposed to "global variable." Local variables include internal variables, input variables, output variables, in-out variables, and external variables.
main memory	The memory inside the CPU Unit that is used by the CPU Unit to execute the OS and user program.
major fault level Controller error	An error for which all NJ/NX-series Controller control operations stop. The CPU Unit immediately stops user program execution and turns OFF the loads for all slaves and Units (including remote I/O).
MC Test Run	A function to check motor operation and wiring from the Sysmac Studio.
memory used for CJ-series Units	One type of I/O memory in an NJ-series CPU Unit. It contains addresses that can be directly specified by the user. It can be accessed only with variables with an AT attribute. This memory is used to access CJ-series Units and CJ-series networks.
minor fault level Controller error	An error for which part of the control operations for one of the function modules in the NJ/NX-series Controller stop. The NJ/NX-series CPU Unit continues operation even after a minor fault level Controller error occurs.
Motion Control Function Module	One of the function modules. The MC Function Module performs motion control based on commands from the motion control instructions that are executed in the user program.
motion control instruction	A function block instruction that executes motion control. The Motion Control Function Module supports instructions that are based on function blocks for PLCopen® motion control as well as instructions developed specifically for the Motion Control Function Module.
namespace	A system that is used to group and nest the names of functions, function block definitions, and data types.
Network Publish	One of the attributes of a variable. This attribute allows you to use CIP message communications or tag data links to read/write variables from another Controller or from a host computer.
NX Units	Any of the NX-series Units that perform I/O processing with connected external devices. The Communications Coupler Units are not included with the NX Units.
observation	One of the event levels for Controller events or user-defined events. These are minor errors that do not affect control operations, but appear in the event log to notify the user of specific information.
partial fault level Controller error	An error for which all of the control operations for one of the function modules in the NJ/NX-series Controller stop. An NJ/NX-series CPU Unit continues operation even after a partial fault level Controller error.
PDO communications	An abbreviation for process data communications. Data is exchanged between the master and slaves on a process data communications cycle. (The process data communications cycle is the same as the task period of the primary periodic task.)
periodic task	A task for which user program execution and I/O refreshing are performed each period.
PLC Function Module	One of the function modules. This function module executes the user program, sends commands to the Motion Control Function Module, and provides an interface to the USB and SD Memory Card.
POU	An acronym for "program organization unit." A POU is a unit in a program execution model that is defined in IEC 61131-3. A POU contains an algorithm and a local variable table and forms the basic unit used to build a user program. There are three types of POUs: programs, functions, and function blocks.

Term	Description
primary periodic task	The task with the highest priority.
process data communications	One type of EtherCAT communications in which process data objects (PDOs) are used to exchange information cyclically and in realtime. Process data communications are also called PDO communications.
program	Along with functions and function blocks, one of the three types of POUs. Programs are assigned to tasks to execute them.
Range Specification	One of the variable specifications. You can specify a range for a variable in advance. The variable can take only values that are in the specified range.
Retain	One of the attributes of a variable. The values of variables with a Retain attribute are held at the following times. (Variables without a Retain attribute are set to their initial values.) <ul style="list-style-type: none"> • When power is turned ON after power interruption • When the CPU Unit changes to RUN mode • When you specify to not initialize the values when the user program is transferred
SDO communications	One type of EtherCAT communications in which service data objects (SDOs) are used to transmit information whenever required.
Servo Drive/encoder input slave	Any of the EtherCAT slaves that is assigned to an axis. In the NJ/NX-series System, it would be a Servo Drive or Encoder Input Slave Unit.
slave	A device that performs remote I/O for a master.
slave and Unit configurations	A generic term for the EtherCAT configuration and Unit configuration.
Slave Terminal	A building-block remote I/O terminal to which a Communications Coupler Unit and NX Units are mounted. A Slave Terminal is one type of slave.
Special Unit Setup	A generic term for the settings for a Special Unit, including the settings in allocated DM Area words.
structure	One of the derivative data types. It consists of multiple data types placed together into a layered structure.
synchronization	A function that automatically compares the information in the NJ/NX-series Controller with the information in the Sysmac Studio, displays any differences and locations in a hierarchical form, and can be used to synchronize the information.
Sysmac Studio	A computer software application for setting, programming, debugging, and troubleshooting NJ/NX-series Controllers. It also provides operations for motion control and a Simulator.
system common processing	System processing that is performed by the CPU Unit to perform I/O refreshing and the user program execution within a task. Exclusive control of variables between tasks, data trace processing, and other processing is performed.
system service	Processing that is performed by the CPU Unit in unused time between task processing. The system service includes communications processing, SD Memory Card access processing, self-diagnosis processing, and other processing.
system-defined variable	A variable for which all attributes are defined by the system and cannot be changed by the user.
task	An attribute that defines when a program is executed.
task period	The interval at which the primary periodic task or a periodic task is executed.
union	One of the derivative data types. It allows you to handle the same data as different data types.
Unit	A device that mounts to the CPU Rack or an Expansion Rack.
Unit configuration	The configuration information for the Units that are set on the Sysmac Studio. This information tells what Unit models are connected to the CPU Unit and where they are connected.
upload	To transfer data from the Controller to the Sysmac Studio with the synchronization operation of the Sysmac Studio.
user program	All of the programs in one project.
user-defined event	One of the events in the NJ/NX-series System. These events are defined by the user. "User-defined events" is a generic term for user-defined errors and user-defined information.

Term	Description
user-defined variable	A variable for which all of the attributes are defined by the user and can be changed by the user.
variable	A representation of data, such as a numeric value or character string, that is used in a user program. You can change the value of a variable by assigned the required value. "Variable" is used as opposed to "constant," for which the value does not change.
variable memory	A memory area that contains the present values of variables that do not have AT specifications. It can be accessed only with variables without an AT attribute.

Revision History

A manual revision code appears as a suffix to the catalog number on the front and back covers of the manual.

Cat. No. W535-E1-01

↑
Revision code

Revision code	Date	Revised content
01	April 2015	Original production

Sections in this Manual

1	Introduction to NX-series Controllers	1
2	System Configuration	2
3	Configuration Units	3
4	Installation and Wiring	4
5	Troubleshooting	5
6	Inspection and Maintenance	6
A	Appendices	A
I	Index	I

1

Introduction to NX-series Controllers

This section describes the features, basic system configuration, specifications, and overall operating procedure of an NX-series Controller.

1-1	The NX-series Controllers	1-2
1-1-1	Features	1-2
1-1-2	Introduction to the System Configurations	1-5
1-2	Specifications	1-8
1-3	Overall Operating Procedure for the NX-series Controller	1-12
1-3-1	Overall Procedure	1-12
1-3-2	Procedure Details	1-13

1-1 The NX-series Controllers

The SYSMAC NX-series Controllers are next-generation machine automation controllers that provide the functionality and high-speed performance that are required for machine control. They provide the safety, reliability, and maintainability that are required of industrial controllers.

The NX-series Controllers provide the functionality of previous OMRON PLCs, and they also provide the functionality that is required for motion control. Synchronized control of I/O devices on high-speed EtherCAT can be applied to safety devices, vision systems, motion equipment, discrete I/O, and more.

OMRON offers the new Sysmac Series of control devices designed with unified communications specifications and user interface specifications. The NX-series Machine Automation Controllers are part of the Sysmac Series. You can use them together with EtherCAT slaves, other Sysmac products, and the Sysmac Studio Automation Software to achieve optimum functionality and ease of operation.

With a system that is created from Sysmac products, you can connect components and commission the system through unified concepts and usability.

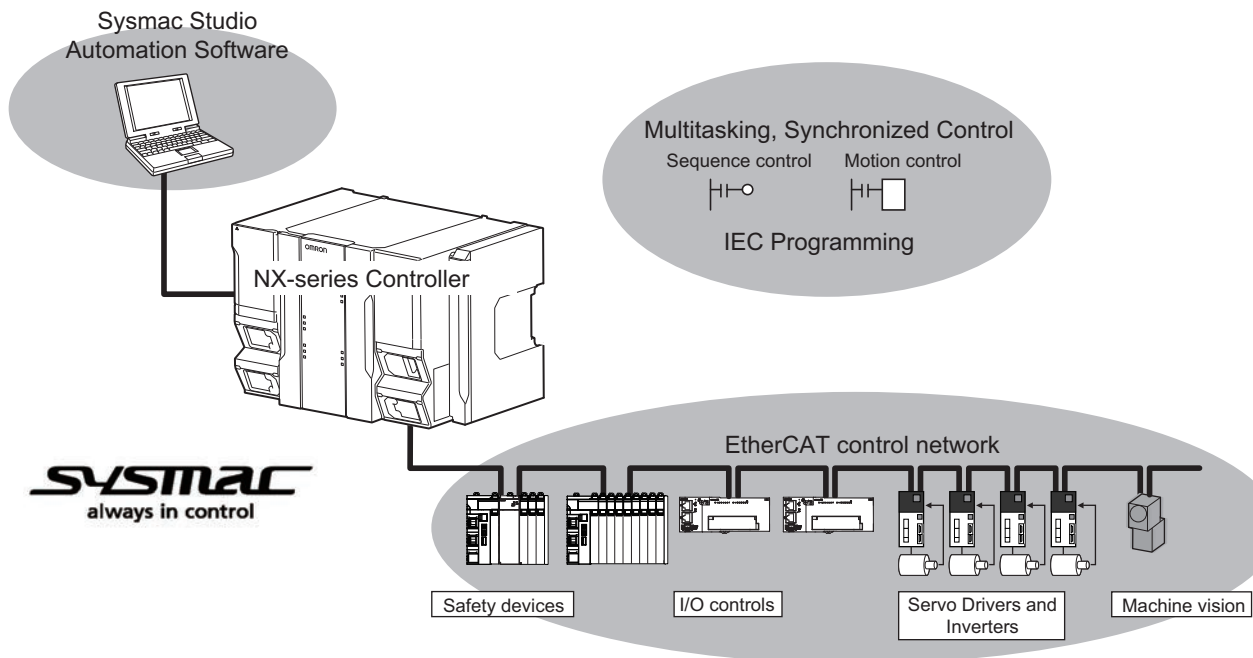

1-1-1 Features

Hardware Features

- **Standard-feature EtherCAT Control Network Support**

All CPU Units provide an EtherCAT master port for EtherCAT communications.

EtherCAT is an advanced industrial network system that achieves faster, more-efficient communications. It is based on Ethernet. Each node achieves a short fixed communications cycle time by transmitting Ethernet frames at high speed.

The standard-feature EtherCAT control network allows you to connect all of the devices required for machine control (e.g., I/O systems, Servo Drives, Inverters, and machine vision) to the same network.

- **Support for EtherCAT Slave Terminals**

You can use EtherCAT Slave Terminals to save space. You can also flexibly build systems with the wide variety of NX Units.

- **Achieving a Safety Subsystem on EtherCAT**

You can use NX-series Safety Control Units to integrate safety controls in a sequence and motion control system as a subsystem on EtherCAT.

- **Standard-feature Two EtherNet/IP Communications Ports**

All CPU Units provide two EtherNet/IP ports for EtherNet/IP communications.

EtherNet/IP is a multi-vendor industrial network that uses Ethernet. You can use it for networks between Controllers or as a field network. The use of standard Ethernet technology allows you to connect to many different types of general-purpose Ethernet devices.

- **Standard-feature USB Port**

You can connect a computer that runs the Support Software directly to the CPU Unit with a USB connection.

- **Standard-feature SD Memory Card Slot**

You can access an SD Memory Card that is mounted in the CPU Unit from the user program.

- **Highly Reliable Hardware**

The NX-series Controllers provide the hardware reliability and RAS functions that you expect of a PLC.

- **Parallel Execution of Tasks with a Multi-core Processor**

The NX701-□□□□ CPU Unit has a multi-core processor that can execute more than one task in parallel. This enables high-speed control of even large-scale devices.

Software Features

- **Integrated Sequence Control and Motion Control**

An NX-series CPU Unit can perform both sequence control and motion control. You can simultaneously achieve both sequence control and multi-axes synchronized control. Sequence control, motion control, and I/O refreshing are all executed in the same control period.

The same control period is also used for the process data communications cycle for EtherCAT. This enables precise sequence and motion control in a fixed period with very little deviation.

- **Multitasking**

You assign I/O refreshing and programs to tasks and then specify execution conditions and execution order for them to flexibly combine controls that suit the application.

- **Programming Languages Based on the IEC 61131-3 International Standard**

The NX-series Controllers support language specifications that are based on IEC 61131-3. To these, OMRON has added our own improvements. Motion control instructions that are based on PLCopen[®] standards and an instruction set (POUs) that follows IEC rules are provided.

- **Programming with Variables to Eliminate Worrying about the Memory Map**

You access all data through variables in the same way as for the advanced programming languages that are used on computers. Memory in the CPU Unit is automatically assigned to the variables that you create so that you do not have to remember the physical addresses.

- **A Wealth of Security Features**

The many security features of the NX-series Controllers include operation authority settings and restriction of program execution with IDs.

- **Complete Controller Monitoring**

The CPU Unit monitors events in all parts of the Controller, including mounted Units and EtherCAT slaves.

Troubleshooting information for errors is displayed on the Sysmac Studio or on an NS-series PT. Events are also recorded in logs.

- **Sysmac Studio Automation Software**

The Sysmac Studio provides an integrated development environment that covers not only the Controller, but also covers peripheral devices and devices on EtherCAT. You can use consistent procedures for all devices regardless of the differences in the devices. The Sysmac Studio supports all phases of Controller application, from designing through debugging, simulations, commissioning, and changes during operation.

- **A Wealth of Simulation Features**

The many simulation features include execution, debugging, and task execution time estimates on a virtual controller.

1-1-2 Introduction to the System Configurations

The NX Series supports the following system configurations.

● Basic System Configurations

The NX-series basic configurations include the EtherCAT network configuration and the Support Software.

- EtherCAT Network Configuration

You can use the built-in EtherCAT port to connect to EtherCAT Slave Terminals, to general-purpose slaves for analog and digital I/O, and to Servo Drives and encoder input slaves. An EtherCAT network configuration enables precise sequence and motion control in a fixed cycle with very little deviation.

- Support Software

The Support Software is connected to the peripheral USB port on the CPU Unit with a commercially available USB cable. You can also connect it through an Ethernet cable that is connected to the built-in EtherNet/IP port.

Refer to 3-4-2 Connection on page 3-15 for details on the connection configuration of the Support Software.

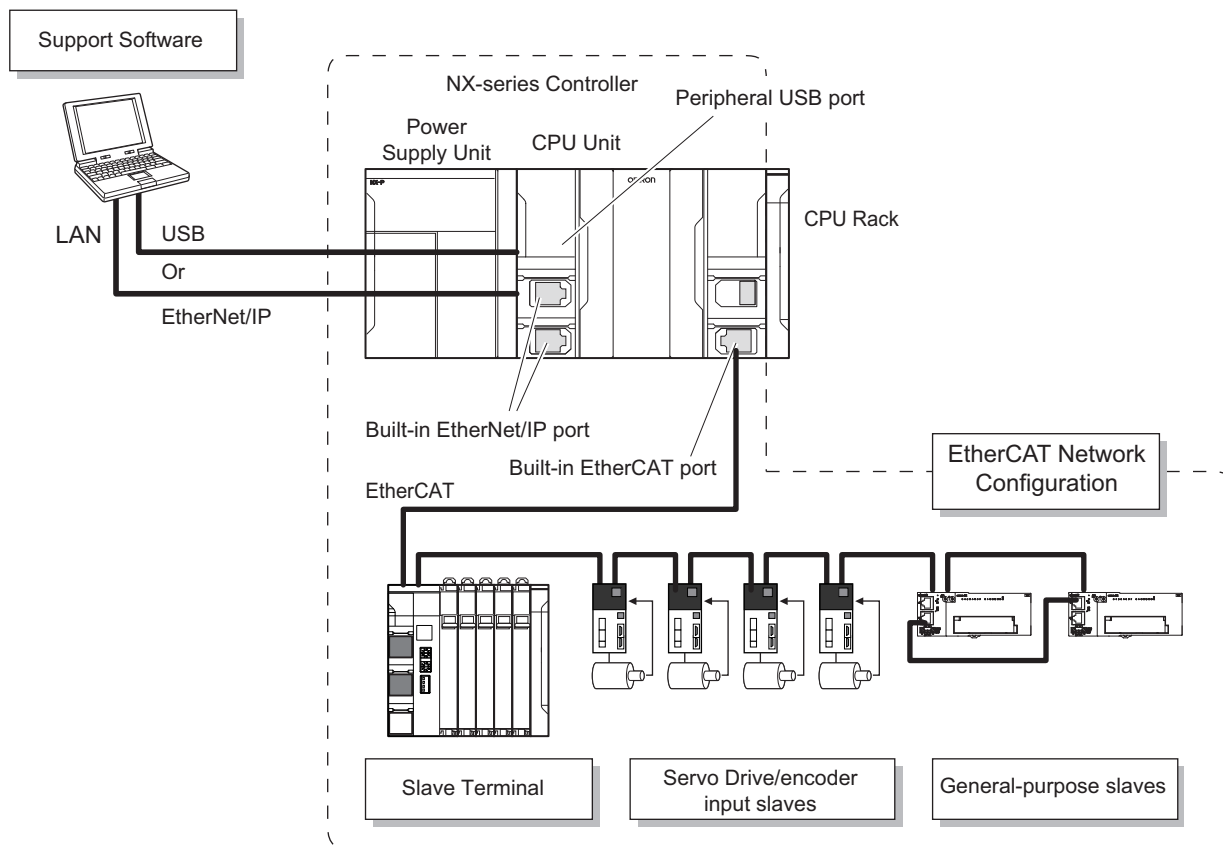

Precautions for Correct Use

NX Units should be connected to Slave Terminals. The NX bus connector of the CPU Unit is provided for future expansion so that it cannot be used to connect any NX Unit.



Additional Information

You can connect the Sysmac Studio directly to the Communications Coupler Unit to set up the Slave Terminal. Refer to the *NX-series EtherCAT Coupler Units User's Manual* (Cat. No. W519) for details.

● Network Configurations

- Host computers, HMIs, and other NJ/NX-series Controllers are connected to the built-in EtherNet/IP port.
- A DeviceNet network is connected to a CJ-series DeviceNet Unit. A serial communications network is connected to a CJ-series Serial Communications Unit.

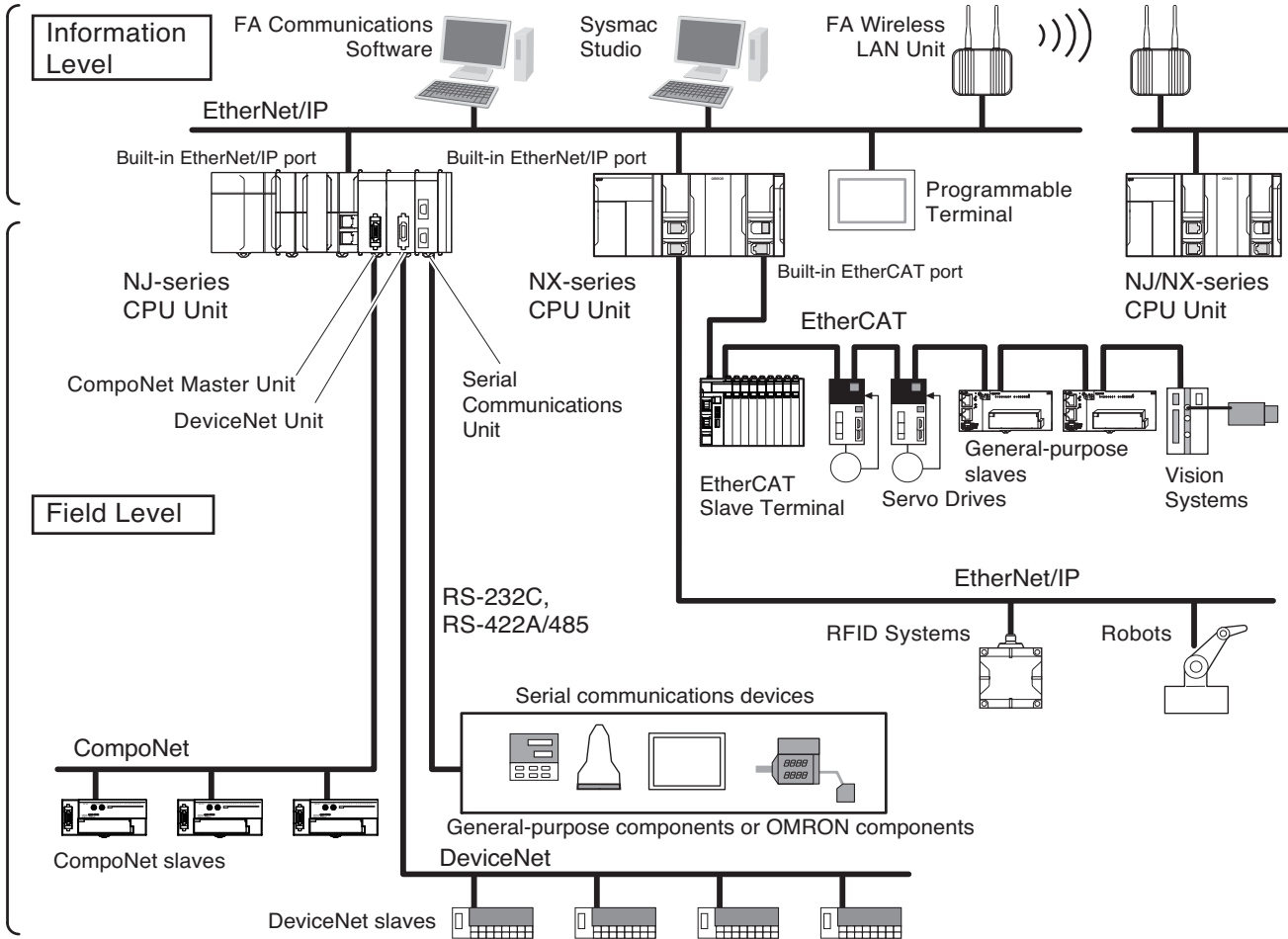

Refer to the *NJ/NX-series CPU Unit Software User's Manual* (Cat. No. W501) for details on the network configuration.

● Support Software

You can use the following Support Software to set up, monitor, and debug an NX-series Controller.

- **Sysmac Studio**

The Sysmac Studio is the main Support Software that you use for an NX-series Controller. On it, you can set up the Controller configurations, parameters, and programs, and you can debug and simulate operation.

- **Other Support Software**

The following Support Software is also included in the Sysmac Studio Software Package Standard Edition.

Configuration software	Application
Sysmac Studio	The Sysmac Studio is used for sequence control, motion control, and all other operations except those described below.
Network Configurator	The Network Configurator is used for tag data links on EtherNet/IP ports. ^{*1}
CX-Integrator	The CX-Integrator is used for remote I/O communications with a CJ-series DeviceNet Unit or CJ-series CompoNet Master Unit.
CX-Protocol	The CX-Protocol is used for protocol macros with the CJ-series Serial Communications Units.
CX-Designer	The CX-Designer is used to create screens for NS-series PTs.

*1. If the NJ/NX-series Controller is a target device, you may also use Sysmac Studio version 1.10 or higher. Use the Network Configurator if a CS/CJ-series PLC operates as the originator device.

1-2 Specifications

This section gives the main specifications of the NX-series Controllers.

Item		NX701-			
		17□□	16□□		
Processing time	Instruction execution times	LD instruction	0.37 ns or more		
		Math instructions (for long real data)	3.2 ns or more		
Programming	Program capacity* ¹	Size	80 MB		
		Quantity	Number of POU definitions	6,000	
			Number of POU Instances	48,000	
	Memory capacity for variables	Retain attributes* ²	Size	4 MB	
			Number of variables	40,000	
		No Retain attributes* ³	Size	256 MB	
			Number of variables	360,000	
	Data types	Number of data types	8,000		
	Memory for CJ-series Units (Can be specified with AT specifications for variables.)	CIO Area	---		
		Work Area	---		
		Holding Area	---		
DM Area		---			
EM Area		---			
Motion control	Number of controlled axes	Maximum number of controlled axes* ⁴	256 axes	128 axes	
		Maximum number of used real axes* ⁵	256 axes	128 axes	
		Maximum number of axes for single-axis control	256 axes	128 axes	
		Maximum number of axes for linear interpolation axis control	4 axes per axes group		
		Number of axes for circular interpolation axis control	2 axes per axes group		
	Maximum number of axes groups	64 axes groups			
	Motion control period	The same control period as that is used for the process data communications cycle for EtherCAT.			
	Cams	Number of cam data points	Maximum points per cam table	65,535 points	
			Maximum points for all cam tables	1,048,560 points	
		Maximum number of cam tables	640 tables		
	Position units	Pulse, mm, μm, nm, degree, and inch			
Override factors	0.00% or 0.01% to 500.00%				
Peripheral USB port	Supported services	Sysmac Studio connection			
	Physical layer	USB 2.0-compliant B-type connector			
	Transmission distance	5 m max.			

Item		NX701-			
		17□□	16□□		
Built-in Ether-Net/IP port	Number of ports		2		
	Physical layer		10BASE-T, 100BASE-TX, or 1000BASE-T		
	Frame length		1,514 bytes max.		
	Media access method		CSMA/CD		
	Modulation		Baseband		
	Topology		Star		
	Baud rate		1 Gbps (1000BASE-T)		
	Transmission media		STP (shielded, twisted-pair) cable of Ethernet category 5, 5e or higher		
	Maximum transmission distance between Ethernet switch and node		100 m		
	Maximum number of cascade connections		There are no restrictions if an Ethernet switch is used.		
	CIP service: Tag data links (cyclic communications)	Maximum number of connections		256 per port 512 total	
		Packet interval* ⁶		Can be set for each connection. 0.5 to 10,000 ms in 0.5-ms increments	
		Permissible communications band		40,000 pps* ⁷ (including heartbeat)	
		Maximum number of tag sets		256 per port 512 total	
		Tag types		Network variables	
		Number of tags per connection (i.e., per tag set)		8 (7 tags if Controller status is included in the tag set.)	
		Maximum number of tags		256 per port 512 total	
		Maximum link data size per node (total size for all tags)		369,664 bytes	
		Maximum data size per connection		1,444 bytes	
		Maximum number of registrable tag sets		256 per port 512 total (1 connection = 1 tag set)	
		Maximum tag set size		1,444 bytes (Two bytes are used if Controller status is included in the tag set.)	
		Multi-cast packet filter* ⁸		Supported.	
	CIP message service: Explicit messages	Class 3 (number of connections)		128 per port 256 total (clients plus server)	
		UCMM (non-connection type)	Maximum number of clients that can communicate at one time	32 per port 64 total	
Maximum number of servers that can communicate at one time			32 per port 64 total		
Number of TCP sockets		30			

Item		NX701-		
		17□□	16□□	
Built-in EtherCAT port	Communications standard		IEC 61158 Type12	
	EtherCAT master specifications		Class B (Feature Pack Motion Control compliant)	
	Physical layer		100BASE-TX	
	Modulation		Baseband	
	Baud rate		100 Mbps (100BASE-TX)	
	Duplex mode		Auto	
	Topology		Line, daisy chain, and branching	
	Transmission media		Twisted-pair cable of category 5 or higher (double-shielded straight cable with aluminum tape and braiding)	
	Maximum transmission distance between nodes		100 m	
	Maximum number of slaves		512	
	Range of node addresses that can be set		1 to 512	
	Maximum process data size		Input: 11,472 bytes Output: 11,472 bytes However, the maximum number of process data frames is 8.	
	Maximum process data size per slave		Input: 1,434 bytes Output: 1,434 bytes	
	Communications cycle		Primary periodic task 125 μs 250 μs to 8 ms in 250-μs increments Priority-5 periodic task 125 μs 250 μs to 100 ms in 250-μs increments	
Sync jitter		1 μs max.		
Unit configuration	Maximum number of connectable Units	Maximum number of CJ Units per CPU Rack or Expansion Rack		---
		Maximum number of CJ Units for entire controller		---
		Maximum number of NX Units for entire controller		4,000 (On EtherCAT Slave Terminals)
	Maximum number of Expansion Racks		0	
	I/O capacity	Maximum number of I/O points on CJ-series Units		---
	Power Supply Unit for CPU Rack and Expansion Racks	Model		NX-PA9001 NX-PD7001
Power OFF detection time		AC power supply		30 to 45 ms
		DC power supply		5 to 20 ms
Internal clock		At ambient temperature of 55°C: -3.5 to 0.5 min error per month At ambient temperature of 25°C: -1.5 to 1.5 min error per month At ambient temperature of 0°C: -3 to 1 min error per month		

- *1. Execution objects and variable tables (including variable names)
- *2. Does not include Holding, DM, and EM Area memory for CJ-series Units.
- *3. Does not include CIO and Work Area memory for CJ-series Units.
- *4. This is the total for all axis types.
- *5. This is the total number of axes that are set as **servo axes** or **encoder axes** and are also set as **used axes**.

- *6. Data will be refreshed at the set interval, regardless of the number of nodes.
- *7. “pps” means packets per second, i.e., the number of communications packets that can be sent or received in one second.
- *8. As the EtherNet/IP port implements the IGMP client, unnecessary multi-cast packets can be filtered by using an Ethernet switch that supports IGMP Snooping.

1-3 Overall Operating Procedure for the NX-series Controller

This section gives the overall operating procedure of the NX-series Controllers and then describes it in more detail.

1-3-1 Overall Procedure

The overall procedure to use an NX-series Controller is given below.

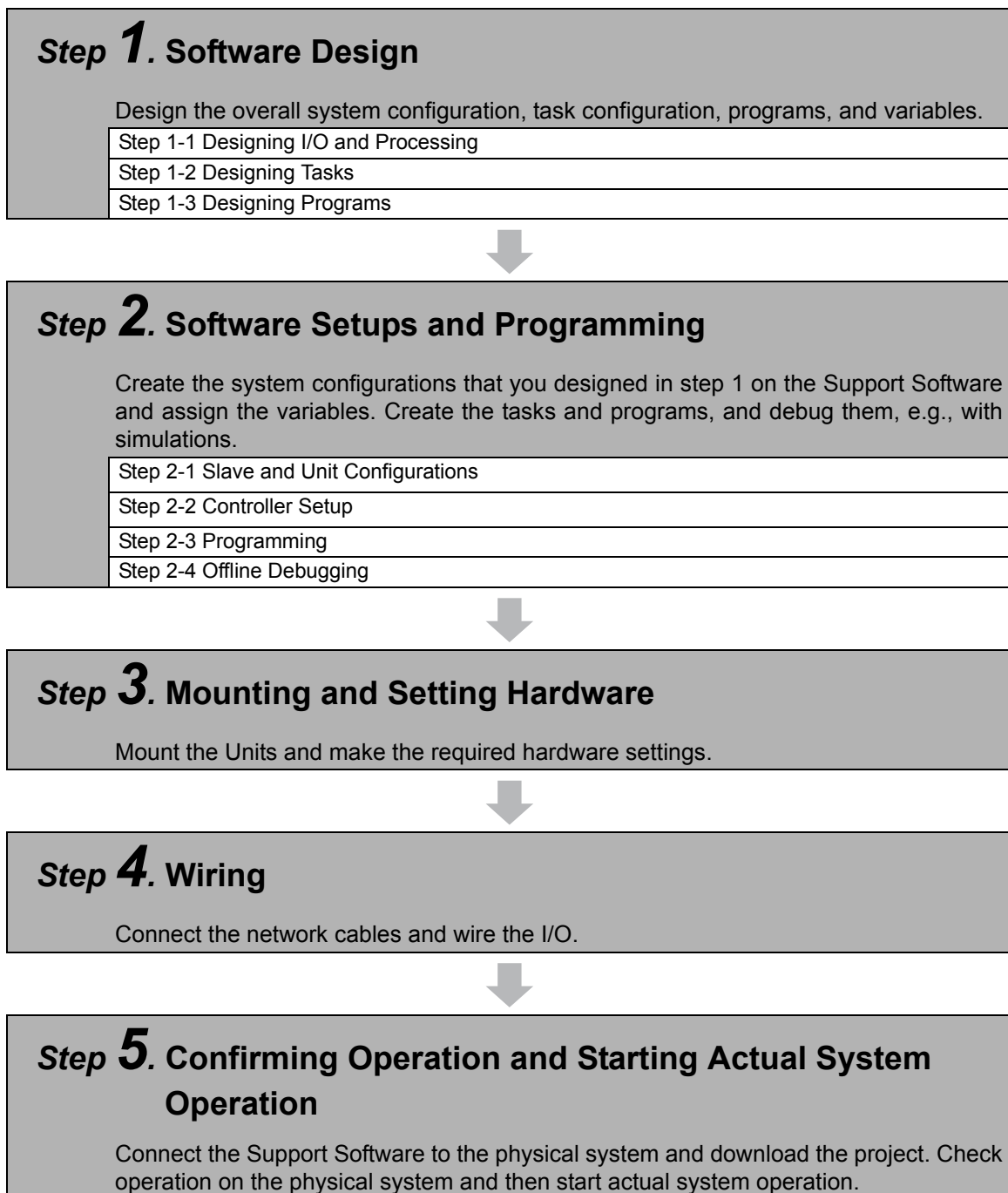

1-3-2 Procedure Details

Step 1. Software Design

Step	Description	Reference
Step 1-1 Designing I/O and Processing	<ul style="list-style-type: none"> External I/O devices and unit configuration Refresh periods for external devices Program contents 	<i>Section 3 Configuration Units</i>



Step 1-2 Designing Tasks	<ul style="list-style-type: none"> Task configuration Relationship between tasks and programs Task periods Slave and Unit refresh times Exclusive control methods for variables between tasks 	<i>NJ/NX-series CPU Unit Software User's Manual (Cat. No. W501)</i>
-------------------------------------	--	---



Step 1-3 Designing Programs		
POU (Program Organization Unit) Design	<ul style="list-style-type: none"> Programs Functions and function blocks Determining the algorithm languages 	<i>NJ/NX-series CPU Unit Software User's Manual (Cat. No. W501)</i>
Variable Design	<ul style="list-style-type: none"> Defining variables that you can use in more than one POU and variables that you use in only specific POUs Defining the variables names for the device variables that you use to access slaves and Units Defining the attributes of variables, such as the Name and Retain attributes Designing the data types of variables 	<i>NJ/NX-series CPU Unit Software User's Manual (Cat. No. W501)</i>



Step 2. Software Setups and Programming

Step	Description	Sysmac Studio Operations	Reference
Project Creation	<ol style="list-style-type: none"> Create a project in the Sysmac Studio. Insert a Controller. 	New Project Button Insert – Controller	<i>Sysmac Studio Version 1 Operation Manual (Cat. No. W504)</i>



The following *Controller Configurations and Setup* and the *Programming and Task Settings* can be performed in either order.

Step 2-1 Slave and Unit configurations			
1) Creating the Slave and Unit Configurations	<ol style="list-style-type: none"> Creating the slave configuration and Unit configuration either offline or online. (For online configuration, make the online connection that is described in step 5.) Setting up any Slave Terminals that are used. 	EtherCAT Slave Setting Editor Unit Editor	<i>NJ/NX-series CPU Unit Software User's Manual (Cat. No. W501)</i> <i>NX-series EtherCAT Coupler Unit User's Manual (Cat. No. W519)</i>



2) Assigning Device Variables to I/O Ports	Registering device variables in variable table (Variable names are user defined or automatically created.)	I/O Map	<i>NJ/NX-series CPU Unit Software User's Manual</i> (Cat. No. W501)
---	---	---------	---



(The following step is for motion control.)

3) Creating the Axes and Assigning Them to the Servo Drive/Encoder Input Slaves	Creating the axes and setting them as real axes or virtual axes. Creating <i>axes groups</i> to perform interpolated axes control.	Configurations and Setup – Motion Control Setup	<i>NJ/NX-series CPU Unit Software User's Manual</i> (Cat. No. W501)
--	---	--	---



Step 2-2 Controller Setup	Setting the following parameters from the Sysmac Studio		<i>NJ/NX-series CPU Unit Software User's Manual</i> (Cat. No. W501)
	Setting the initial values for the PLC Function Module	Configurations and Setup – Controller Setup – Operation Settings	
	(To use motion control) Setting the initial settings for the Motion Control Function Module	Configurations and Setup – Motion Control Setup	
	Setting the initial values for the EtherCAT Function Module	Configurations and Setup – EtherCAT	
Setting the initial values for the EtherNet/IP Function Module	Configurations and Setup – Controller Setup – Built-in EtherNet/IP Port Settings		



Step 2-3 Programming			
1) Registering Variables	<ul style="list-style-type: none"> Registering the variables used by more than one POU in the global variable table with Sysmac Studio Registering the local variable table for each program Registering the local variable table for each function block and function 	Global variable Table Editor Local Variable Table Editor	<i>Sysmac Studio Version 1 Operation Manual</i> (Cat. No. W504) <i>NJ/NX-series CPU Unit Software User's Manual</i> (Cat. No. W501)
2) Writing Algorithms for POU's	Writing the algorithms for the POU's (programs, function blocks, and functions) in the required languages	Programming Editor	<i>NJ/NX-series CPU Unit Software User's Manual</i> (Cat. No. W501) <i>NJ/NX-series Instructions Reference Manual</i> (Cat. No. W502) <i>NJ/NX-series Motion Control Instructions Reference Manual</i> (Cat. No. W508)

3) Setting the Tasks	Making task settings	Configurations and Setup – Task Settings	<i>NJ/NX-series CPU Unit Software User's Manual</i> (Cat. No. W501)
-----------------------------	----------------------	---	---



Step 2-4 Offline Debugging	Checking the algorithms and task execution times on the Simulator (virtual controller)		<i>NJ/NX-series CPU Unit Software User's Manual</i> (Cat. No. W501)
-----------------------------------	--	--	---



Step 3. Mounting and Setting Hardware

Step	Description	Reference
1) Mounting	<ul style="list-style-type: none"> Connecting adjacent Units Mounting to DIN Track 	<i>4-3 Mounting Units</i> on page 4-9
2) Setting Hardware	<ul style="list-style-type: none"> Setting the node addresses of the EtherCAT slaves 	Operation manuals for the EtherCAT slaves



Step 4. Wiring

Step	Description	Reference
1) Connecting Ethernet Cable	<ul style="list-style-type: none"> Connecting the built-in EtherCAT port Connecting the built-in EtherNet/IP port 	<i>4-4 Wiring</i> on page 4-31
2) Wiring I/O	<ul style="list-style-type: none"> Wiring I/O to EtherCAT slaves 	Operation manuals for the EtherCAT slaves <i>4-4 Wiring</i> on page 4-31
	<ul style="list-style-type: none"> Checking wiring 	<i>Sysmac Studio Version 1 Operation Manual</i> (Cat. No. W504)
3) Connecting the Computer That Runs the Sysmac Studio	<ul style="list-style-type: none"> Connecting USB Cable Connecting the built-in EtherNet/IP port 	<i>Sysmac Studio Version 1 Operation Manual</i> (Cat. No. W504)



Step 5. Checking Operation and Starting Operation on the Actual System

Step	Description	Sysmac Studio Operations	Reference
1) Online Connection to Sysmac Studio and Project Download	<p>Turn ON the power supply to the Controller and place the Sysmac Studio online. Then, download the project. *1</p> <p>Perform this step before you create the slave configuration or Unit configuration from the mounted Units in step 2-1.</p>	Controller – Communications Setup – Controller – Synchronization	<i>NJ/NX-series CPU Unit Software User's Manual</i> (Cat. No. W501)



2) Operation Check on Controller	<ol style="list-style-type: none"> 1. Check the wiring by using forced refreshing of real I/O from the I/O Map or Watch Tab Page. 2. For motion control, use the MC Test Run operations in PROGRAM mode to check the wiring. Then check the motor rotation directions for jogging, travel distances for relative positioning (e.g., for electronic gear settings), and homing operation. 3. Change the Controller to RUN mode and check the operation of the user program. 	<p style="text-align: center;">---</p>	<i>NJ/NX-series CPU Unit Software User's Manual (Cat. No. W501)</i>
---	---	--	---



3) Actual Controller Operation	Start actual operation.	<p style="text-align: center;">---</p>	<p style="text-align: center;">---</p>
---------------------------------------	-------------------------	--	--

*1. Use the Synchronize Menu of the Sysmac Studio to download the project.

2

System Configuration

This section describes the basic system configuration used for NX-series Controllers.

2-1 Basic System Configuration	2-2
2-1-1 EtherCAT Network Configuration	2-3
2-2 Connecting to the Sysmac Studio	2-6
2-3 Network Configuration	2-7

2-1 Basic System Configuration

An NX-series Controller supports the following two types of configurations.

- Basic Configuration

The basic configurations include the CPU Unit and the Configuration Units that are controlled directly by the CPU Unit. There are two basic configurations.

- a) EtherCAT network configuration

- Other Network Configurations

These are the configurations of the systems that are connected to the CPU Unit's built-in EtherNet/IP port and Communications Units.

- **Basic Controller Configuration**

With an NX-series CPU Unit, you can use an EtherCAT network as a basic system.

With the EtherCAT network system of the NX-series CPU Unit, the period for sequence processing and motion processing in the CPU Unit is the same as the EtherCAT communications period.

This enables high-precision sequence control and motion control with a constant period and little fluctuation.

For information on EtherCAT, refer to the *NJ/NX-series CPU Unit Built-in EtherCAT Port User's Manual* (Cat. No. W505).

2-1-1 EtherCAT Network Configuration

The EtherCAT network configuration consists of an NX-series CPU Unit, an NX-series Power Supply Unit, an End Cover, and the EtherCAT slaves.

You use the built-in EtherCAT master port on the NX-series CPU Unit to connect EtherCAT slaves.

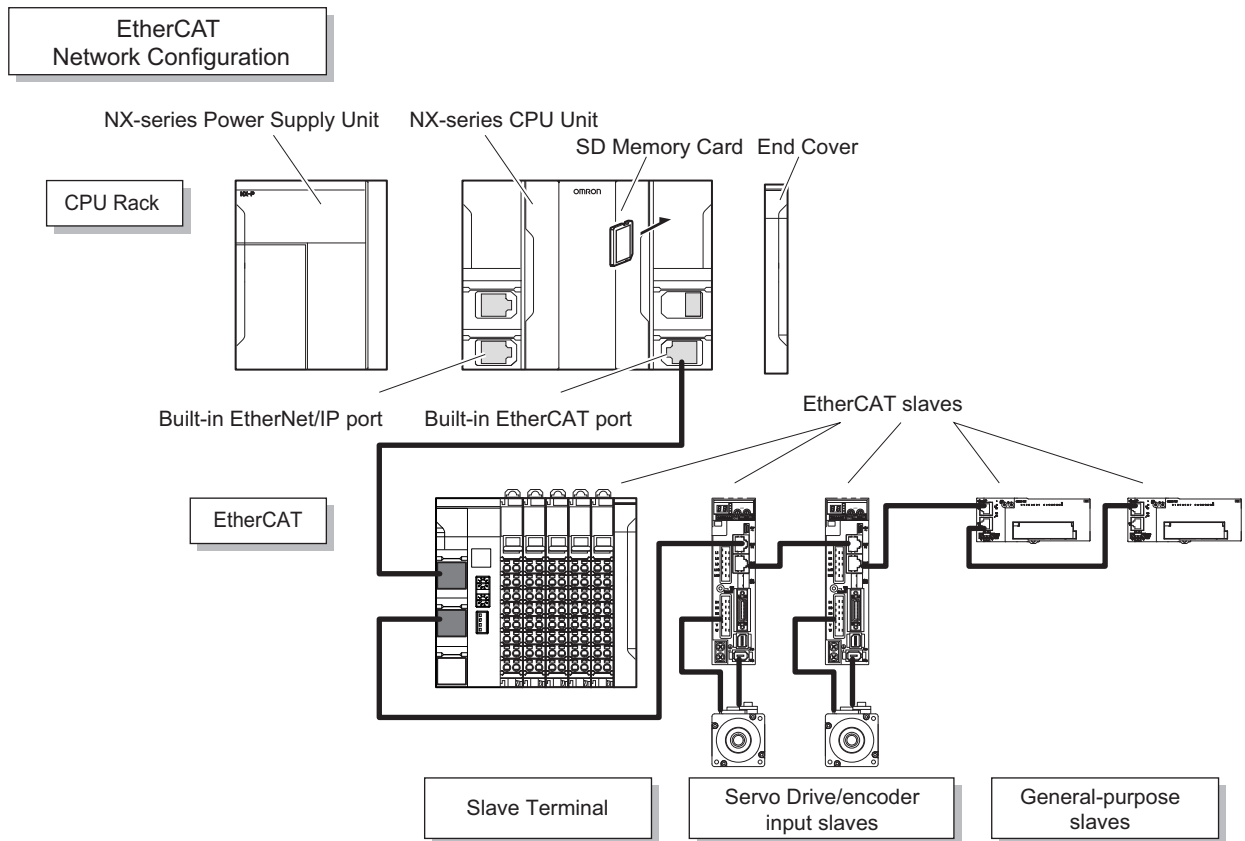

For information on the system configuration of an EtherCAT network, refer to the *NJ/NX-series CPU Unit Built-in EtherCAT Port User's Manual* (Cat. No. W505).

Configuration Units

● NX-series CPU Units

The Unit that serves as the center of control for a Machine Automation Controller. It executes tasks, refreshes I/O for other Units and slaves, etc. The NX-series CPU Unit includes the NX701-□□□□.

Refer to 3-1 CPU Units on page 3-2 for the models and specifications of individual NX-series CPU Units.

● NX-series Power Supply Units

The Unit that supplies power to a CPU Rack including an NX-series CPU Unit. AC type and DC type are provided for the Power Supply Unit.

Refer to *3-3 Power Supply Units* on page 3-11 for the models and specifications of individual NX-series Power Supply Units.



Precautions for Safe Use

Do not use the Power Supply Units in the system beyond the rated supply capacity ranges.

Doing so may result in operation stopping, incorrect operation, or failure to correctly back up required data at power interruptions.

● SD Memory Card

With the NX-series CPU Unit, various data can be saved, backed up, restored and compared using the SD Memory Card.

Refer to *3-2 SD Memory Cards* on page 3-10 for the models and specifications of individual SD Memory Card.

● End Cover

A cover to protect the NX-series CPU Unit.

● EtherCAT Slaves

A device that exchanges data with the EtherCAT master built into NX-series Controller through the EtherCAT network. The device provides non-synced slaves and synced slaves.

Refer to the manuals for the specific EtherCAT slaves for details.

● USB Cable

A cable to connect the CPU Unit and the Sysmac Studio.

Name	Model	Specifications
Connecting cable for peripheral USB port	Commercially available USB cable	USB 2.0 certified cable, A connector - B connector, 5.0 m max.

● Recommended Communications Cables for EtherCAT and EtherNet/IP

For EtherCAT, use a shielded twisted-pair cable (double shielding with aluminum tape and braiding) of Ethernet category 5 (100BASE-TX) or higher, and use straight wiring.





For EtherNet/IP, required specification for the communications cables varies depending on the baud rate.

For 100BASE-TX/10BASE-T, use an STP (shielded twisted-pair) cable of Ethernet category 5 or higher. You can use either a straight or cross cable.

For 1000BASE-T, use an STP (double shielding with aluminum tape and braiding) cable of Ethernet category 5e or higher. You can use either a straight or cross cable.

The following table lists wiring materials used for the EtherCAT and EtherNet/IP communications cables.

In the table, materials indicated available for EtherNet/IP 100BASE-TX are available for both of 100BASE-TX and 10BASE-T.

Product			Manufacturer	Cable length [m]	Model
Products for EtherCAT	Size and number of pairs: AWG27 × 4P ^{*1}	Standard type Cable with Connectors on Both Ends (RJ45/RJ45) 	OMRON Corporation	0.3	XS6W-6LSZH8SS30CM-Y
				0.5	XS6W-6LSZH8SS50CM-Y
				1	XS6W-6LSZH8SS100CM-Y
				10	XS6W-6LSZH8SS1000CM-Y
	Size and number of pairs: AWG22 × 2P ^{*2}	Rugged type Cables with Connectors on Both Ends (RJ45/RJ45) 	OMRON Corporation	0.3	XS5W-T421-AMD-K
				0.5	XS5W-T421-BMD-K
				1	XS5W-T421-CMD-K
		Rugged type Cables with Connectors on Both Ends (M12/RJ45) 	OMRON Corporation	2	XS5W-T421-DMC-K
				5	XS5W-T421-GMC-K
				10	XS5W-T421-JMC-K
		Rugged type Cable with Connectors on Both Ends (M12L/RJ45) 	OMRON Corporation	0.3	XS5W-T422-AMC-K
				0.5	XS5W-T422-BMC-K
1	XS5W-T422-CMC-K				
Products for EtherCAT or EtherNet/IP (100BASE-T/100BASE-TX)	Size and number of pairs: AWG24 × 4P	Cables	Tonichi Kyosan Cable, Ltd.	NETSTAR-C5E SAB 0.5 × 4P	
			Kuramo Electric Co.	KETH-SB	
			SWCC Showa Cable Systems Co.	FAE-5004	
	RJ45 Connectors	Panduit Corporation	MPS588		
Products for EtherCAT or EtherNet/IP (100BASE-TX)	Size and number of pairs: AWG22 × 2P ^{*3}	Cables	Kuramo Electric Co., Ltd.	KETH-PSB-OMR	
			Nihon Electric Wire&Cable Co.,Ltd	PNET/B	
		RJ45 Assembly Connectors 	OMRON Corporation	XS6G-T421-1	
Products for EtherNet/IP (100BASE-TX)	Size and number of pairs: 0.5 mm × 4P	Cable	Fujikura	F-LINK-E 0.5 mm × 4P	
		RJ45 Connector	Panduit Corporation	MPS588	

*1. Cables are available in the following lengths: 0.2, 0.3, 0.5, 1, 1.5, 2, 3, 5, 7.5, 10, 15, and 20 m. Refer to the *XS5/XS6 Industrial Ethernet Connectors Catalog* (Cat. No. G019).

*2. Cables are available in the following lengths: 0.3, 0.5, 1, 2, 3, 5, 10, and 15 m. Refer to the *XS5/XS6 Industrial Ethernet Connectors Catalog* (Cat. No. G019).

*3. We recommend that you use combinations of the above Cables and Connectors.

Note When making cables, connect the shield to the connectors at both ends for EtherCAT. For how to connect the shield for EtherNet/IP, refer to the *NJ/NX-series CPU Unit Built-in EtherNet/IP Port User's Manual* (Cat. No. W506).

2-2 Connecting to the Sysmac Studio

Connect the NX-series CPU Unit and the Sysmac Studio through USB or EtherNet/IP.

Refer to *3-4-2 Connection* on page 3-15 for information on how to make the connection between the NX-series CPU Unit and the Sysmac Studio.

2-3 Network Configuration

You can make networks in the following layers with an NJ/NX-series Controller.

For details on communications networks that you can connect to, refer to the *NJ/NX-series CPU Unit Software User's Manual* (Cat. No. W501).

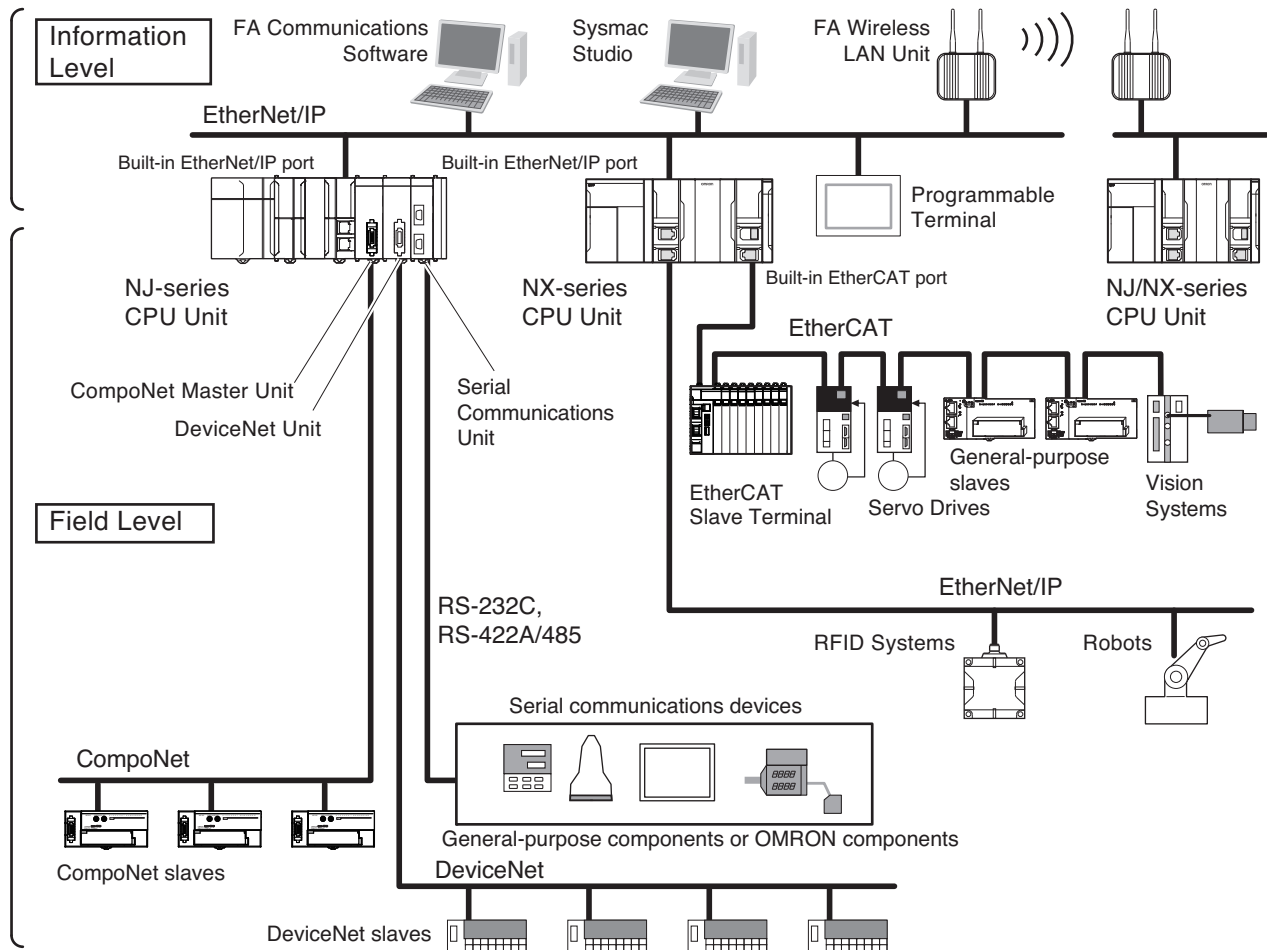

Connection		Connection method
Sysmac Studio		Use USB or the built-in EtherNet/IP port.
Between Controllers	NJ/NX-series Controller or CJ-series PLC	Use the built-in EtherNet/IP port or a port on an EtherNet/IP Unit.* ¹
Devices	Servo Drives, general-purpose slaves and Vision Systems	Use the built-in EtherCAT port.
	Ethernet communications devices	Use the built-in EtherNet/IP port or a port on an EtherNet/IP Unit.* ¹
	Serial communications devices	Mount a Serial Communications Unit* ² and use RS-232C port or RS-422A/485 ports.
	DeviceNet slaves	Mount a DeviceNet Unit* ² and use DeviceNet.
	CompoNet slaves	Mount a CompoNet Master Unit* ² and use CompoNet.
Programmable Terminals		Use the built-in EtherNet/IP port or a port on an EtherNet/IP Unit.* ¹
Servers	Connections to BOOTP server, DNS server, or NTP server	Use the built-in EtherNet/IP port or a port on an EtherNet/IP Unit.* ¹

- *1. Use a CJ-series EtherNet/IP Unit with a unit version of 2.1 or later.
Also, mount the EtherNet/IP Unit to an NJ-series CPU Unit with unit version 1.01 or later, and use Sysmac Studio version 1.02 or higher.
Refer to the *NJ/NX-series CPU Unit Software User's Manual* (Cat. No. W501) for information on version upgrades.
- *2. Mount to an NJ-series CPU Unit.

3

Configuration Units

This section describes configuration devices in the NX-series Unit configuration.

3-1 CPU Units	3-2
3-1-1 Models and Specifications	3-2
3-1-2 Part Names and Functions	3-2
3-2 SD Memory Cards	3-10
3-2-1 Models and Specifications	3-10
3-2-2 Purpose	3-10
3-3 Power Supply Units	3-11
3-3-1 Models and Specifications	3-11
3-3-2 Part Names and Functions	3-12
3-4 Sysmac Studio	3-15
3-4-1 Model Numbers	3-15
3-4-2 Connection	3-15

3-1 CPU Units

This section describes the models and specifications of the NX-series CPU Units as well as the names and functions of the parts.

3-1-1 Models and Specifications

Model	Program capacity	Memory capacity for variables	Number of motion axes
NX701-1700	80 MB	4 MB (Retained during power interruptions) or 256 MB (Not retained during power interruptions)	256 axes
NX701-1600			128 axes

3-1-2 Part Names and Functions

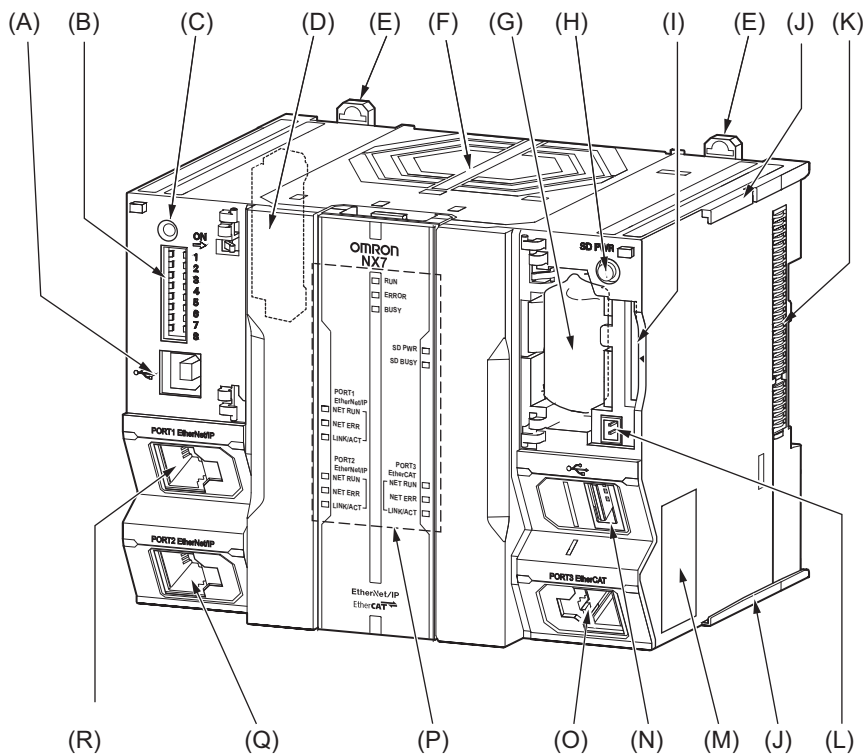

Letter	Name	Function
A	Peripheral USB port	Connects to the Sysmac Studio via a USB cable.
B	DIP switch	Used in Safe Mode ^{*1} or when backing up data ^{*2} . Normally, turn OFF all of the pins.
C	Push switch	Unused. For future expansion, leave it unoperated.
D	Power supply connector	Connects to the Power Supply Unit.
E	DIN Track mounting hooks	These hooks are used to mount the Unit to a DIN Track.
F	Fan Unit	Cools the CPU Unit internally. Refer to <i>Fan Unit</i> on page 3-8.
G	Battery	Battery for backup. Refer to <i>Battery</i> on page 3-8.
H	SD Memory Card power supply switch	Turns OFF the power supply so that you can remove the SD Memory Card. Refer to <i>4-3-6 Installing and Removing the SD Memory Card</i> on page 4-23.
I	SD Memory Card connector	Connects the SD Memory Card to the CPU Unit.
J	Unit hookup guides	These guides are used to mount the End Cover.
K	Connector	Unused. For future expansion, leave it unoperated.
L	Battery connector	Connector to mount the backup battery.
M	ID information indication	Shows the ID information of the CPU Unit. Refer to <i>ID Information Indication</i> on page 3-9.
N	USB host port	Unused. For future expansion, leave it unoperated.
O	Built-in EtherCAT port (port 3)	Connects the built-in EtherCAT with an Ethernet cable.
P	Operation status indicators	Shows the operation status of the CPU Unit. Refer to <i>Operation Status Indicators</i> on page 3-4.
Q	Built-in EtherNet/IP port (port 2)	Connects the built-in EtherNet/IP with an Ethernet cable.
R	Built-in EtherNet/IP port (port 1)	Connects the built-in EtherNet/IP with an Ethernet cable.

*1. To use Safe Mode, set the DIP switch as shown below and then turn ON the power supply to the Controller.

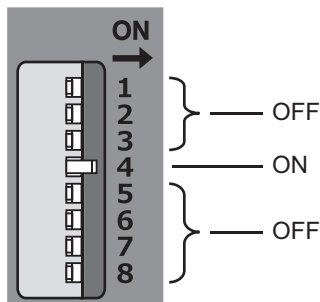

If the power supply to the Controller is turned ON with the CPU Unit in Safe Mode, the CPU Unit will start in PROGRAM mode. Use the Safe Mode if you do not want to execute the user program when the power supply is turned ON or if it is difficult to connect the Sysmac Studio.

For information on Safe Mode, refer to the *NJ/NX-series Troubleshooting Manual* (Cat. No. W503).

*2. Refer to the *NJ/NX-series CPU Unit Software User's Manual* (Cat. No. W501) for details on backing up data.

Operation Status Indicators

There are the indicators to show the operation status of Unit in the center of the front side of the CPU Unit.

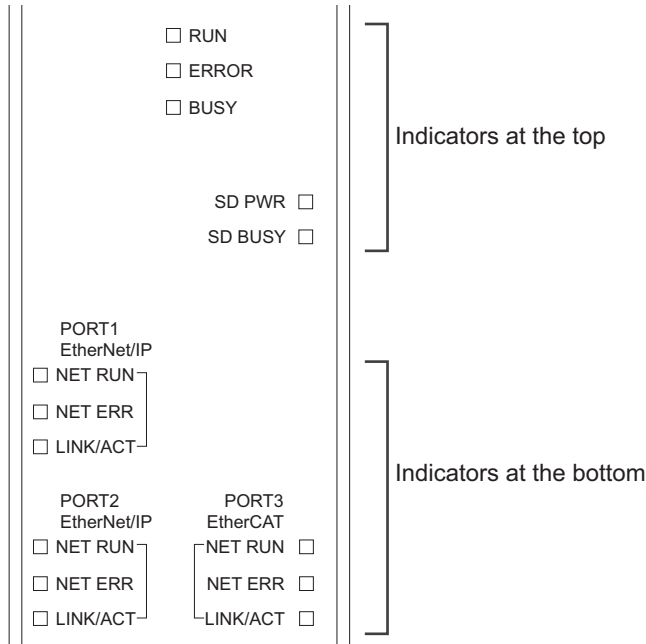



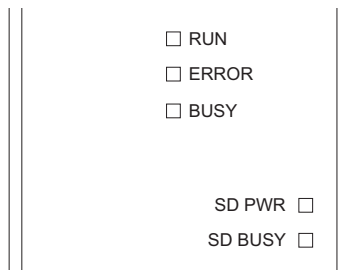











● Indicators at the Top



These indicators show the main operation status of the CPU Unit.

The following table describes these indicators.

Indicator	Color	Status	Meaning
RUN	Green		Lit. The CPU Unit is in normal operation in RUN mode. (The user program is in execution.)
			Flashing at 2-s intervals, then flashing at 0.5-s intervals. The CPU Unit is starting (entering RUN mode or PROGRAM mode at startup).
			Flashing at 2-s intervals continues for 30 seconds or longer. System initialization error occurs.
			Not lit. Operation is stopped in PROGRAM mode, when a CPU Unit reset is in progress, or when any of the following errors occurs. <ul style="list-style-type: none"> • Controller error in the major fault level • CPU error (WDT error)
ERROR	Red		Lit. Self-diagnosis found one of the following errors. <ul style="list-style-type: none"> • Controller error in the major fault level • CPU error
			Flashing at 1-s intervals. Self-diagnosis found one of the following errors. <ul style="list-style-type: none"> • Controller error in the partial fault level (an error in which all control of a Function Module is disabled) • Controller error in the minor fault level (an error in which partial control of a Function Module is disabled) CPU Unit operation will continue for either of these errors. Operation will stop for the Function Module in which a Controller error in the partial fault level occurred. Operation will continue for the Function Module in which a Controller error in the minor fault level occurred.
			Not lit. The CPU Unit is in normal operation, a CPU reset is in progress, or monitored information occurred. (CPU Unit operation will continue.)
BUSY	Yellow		Flashing Built-in non-volatile memory access in progress.
			Not lit. Other than the above.
SD PWR	Green		Lit. Power is being supplied to the SD Memory Card and the SD Memory Card can be used.
			Flashing A backup, restore or verification operation is in progress.*1
			Not lit. The power supply for the SD Memory Card is stopped, an SD Memory Card is not mounted, or the file format of the mounted SD Memory Card is not supported.
SD BUSY	Yellow		Flashing SD Memory Card access in progress.
			Not lit. SD Memory Card access not in progress.

*1. Refer to the *NJ/NX-series CPU Unit Software User's Manual* (Cat. No. W501) for details on backing up data.



Precautions for Safe Use

- Do not turn OFF the power supply to the Controller while the BUSY indicator flashes. While the BUSY indicator is lit, the user program and settings in the CPU Unit are being backed up in the built-in non-volatile memory. The data will not be backed up if the power supply is turned OFF. The next time that the Controller is started, a Controller error in the major fault level will occur and operation will stop.
- Do not turn OFF the power supply or remove the SD Memory Card while SD Memory Card access is in progress (i.e., while the SD BUSY indicator flashes). Data may become corrupted, and the Controller will not operate correctly if it uses corrupted data. To remove an SD Memory Card from the CPU Unit when power is supplied to the CPU Unit, press the SD Memory Card power supply switch and wait for the SD PWR indicator to turn OFF before you remove the SD Memory Card.

You can check the operation status of the CPU Unit with the PWR, RUN, and ERROR indicators at the top of the front panels of the Power Supply Unit and CPU Unit.

Refer to 5-1 *Operation after an Error* on page 5-2 for the procedures to check the operation status of the CPU Unit.

● **Indicators at the Bottom**

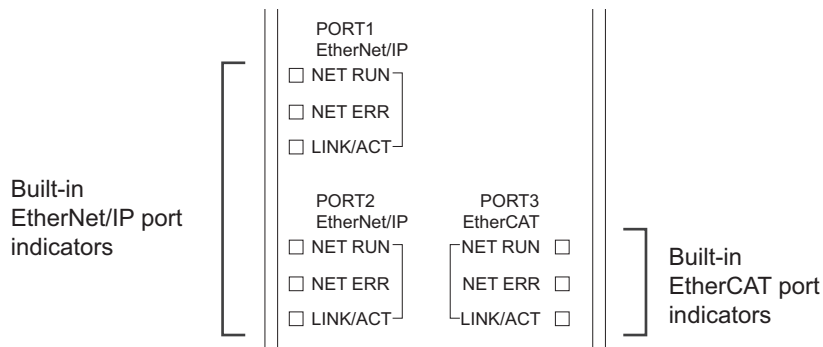







These indicators show the operation status of the built-in ports of the CPU Unit.









Port 1 and port 2 are the indicators for the built-in EtherNet/IP ports, while port 3 is the indicators for the built-in EtherCAT port.

- Built-in EtherNet/IP Ports (Port 1 and Port 2) Indicators

Indicator	Color	Status	Meaning
NET RUN	Green	<input type="checkbox"/>	Not lit. You cannot perform Ethernet communications. • The power supply is OFF or the CPU Unit was reset. • A MAC address error or communications Controller error occurred.
			Flashing Ethernet communications are in progress. • Tag data link connection establishment in progress. • IP address acquisition with BOOTP in progress.
			Lit. Normal startup status.

Indicator	Color	Status	Meaning
NET ERR	Red		Not lit. There are no Ethernet communications errors. • The power supply is OFF or the CPU Unit was reset.
			Flashing An error for which the user can recover operation occurred. • An error occurred in TCP/IP communications or CIP communications. • FTP server setting error, NTP server setting error, etc. • Tag data link setting error, tag data link verification error, etc.
			Lit. An error for which the user cannot recover operation occurred. • A MAC address error or communications Controller error occurred.
LINK/ACT	Yellow		Not lit. A link was not established. • The cable is not connected. • The power supply is OFF or the CPU Unit was reset.
			Flashing The link is established, and data communications are in progress.
			Lit. The link was established.

• Built-in EtherCAT Port (Port 3) Indicators

Indicator	Color	Status	Meaning
NET RUN	Green		Lit. EtherCAT communications are in progress. • Inputs and outputs for I/O data are in operation.
			Flashing EtherCAT communications are established. This indicator shows either of the following conditions. • Only message communications are in operation. • Only message communications and I/O data inputs are in operation.
			Not lit. EtherCAT communications are stopped. • The power supply is OFF or the CPU Unit was reset. • A MAC address error, communications Controller error, or other error occurred.
NET ERR	Red		Lit. A hardware error or unrecoverable error occurred, such as for exception processing.
			Flashing A recoverable error occurred.
			Not lit. There are no errors.
LINK/ACT	Yellow		Lit. A link is established.
			Flashing Data communications are in progress after establishing link. Flashes every time data is sent or received.
			Not lit. The link was not established.

Battery

The following Battery is built in as a standard feature.

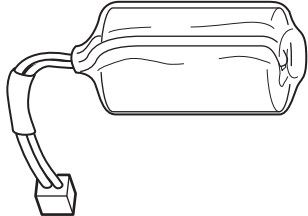
Model	Appearance	Specification
CJ1W-BAT01		<p>Service life: 5 years^{*1}</p> <p>For the battery lifetime, refer to <i>Battery Service Life and Replacement Period</i> on page 6-6.</p> <p>The following values are retained during power interruptions.</p> <ul style="list-style-type: none"> • Values of variables with a Retain attribute • Clock information • Some system-defined variables • Event logs

*1. The Battery installed at the time of purchase is only for monitoring purpose to test the battery backup function. The Battery is exhausted depending on the period from factory checking to actual operation, thus it may not satisfy specified battery lifetime.

Fan Unit

The following Fan Unit is built in as a standard feature.

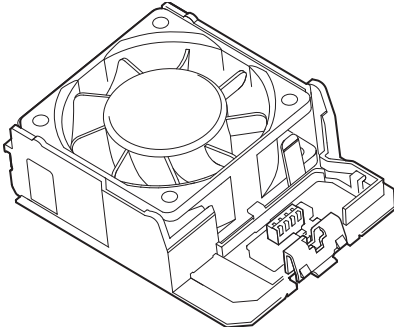
Model	Appearance	Specification
NX-FAN01		<p>Life: 10 years at ambient temperature of 55°C</p> <p>Storage limitation with no power supplied: 1 year</p> <p>Cools the CPU in the CPU Unit.</p>

ID Information Indication

You can check the followings in the ID information indications on the right side of the CPU Unit.

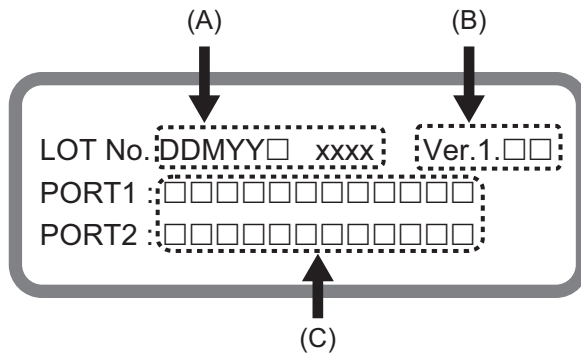

Letter	Name	Function
A	Lot number and serial number	Shows the lot number and the serial number of the CPU Unit. DDMYY: Lot number, □: For use by OMRON, xxxx: Serial number M is 1 to 9 for January to September, X for October, Y for November, and Z for December.
B	Unit version	Shows the unit version of the CPU Unit.
C	MAC addresses	Shows the MAC addresses of the built-in EtherNet/IP ports on the CPU Unit.

3-2 SD Memory Cards

This section describes the models, specifications, and application of the SD Memory Cards.

3-2-1 Models and Specifications

SD cards and SDHC cards are supported, but use one of the following OMRON Cards. OMRON is not responsible for the operation, performance, or write life of any other SD or SDHC card.

Model	Card type	Capacity [GB]	Format	Number of overwrites	Weight
HMC-SD291	SD Card	2	FAT16	100,000	2 g max.
HMC-SD491	SDHC Card	4	FAT32		



Additional Information

Write Protection Key

You will not be able to write to the SD Memory Card if the key is set to the LOCK position. Use this setting to prevent overwriting.



3-2-2 Purpose

You can use the SD Memory Card for the following applications.

- Read and write files in the SD Memory Card with instructions.
- Read and write files in the SD Memory Card from an FTP client on EtherNet/IP.
- Back up, restore, and verify data in the Controller.
- Transfer data from the SD Memory Card to the Controller when the power is turned ON.

Refer to the *NJ/NX-series CPU Unit Software User's Manual* (Cat. No. W501) for details on the functions for SD Memory Cards.

3-3 Power Supply Units

This section describes the models and specifications of the Power Supply Units as well as the names and functions of the parts.

3-3-1 Models and Specifications

NX7-series Power Supply Units

Use an NX7-series Power Supply Unit to supply power to an NX7-series CPU Unit.

Item	Specification	
Model	NX-PA9001	NX-PD7001
Dimensions	80 × 100 × 100 mm (W × H × D)	51 × 100 × 100 mm (W × H × D)
Weight	570 g	290 g
Power supply voltage	100 to 240 VAC (wide-range), 50/60 Hz (85 to 264 VAC, 47 to 63 Hz)	24 VDC (20.4 to 28.8 VDC)
Power consumption	150 VA max.	85 W max.
Inrush current ^{*1}	At 100 VAC: 20 A ^{*2} /8 ms max. for cold start at room temperature At 200 VAC: 40 A ^{*2} /8 ms max. for cold start at room temperature	At 24 VDC: 30 A/2 ms max. for cold start at room temperature 7 A ^{*3} /3 s max. for cold start at room temperature
Output capacity ^{*4}	Total: 90 W max.	Total: 70 W max.
Output terminal (service supply)	Not provided.	
RUN Output	Contact configuration: SPST-NO Switch capacity: 250 VAC, 2 A (resistive load) 120 VAC, 0.5 A (inductive load), 24 VDC, 2A (resistive load)	
Replacement notification function	Not provided.	
Insulation resistance	20 MΩ min. (at 500 VDC) between AC external and GR terminals ^{*5}	--- ^{*6}
Dielectric strength	2,300 VAC 50/60 Hz for 1 min between AC external and GR terminals ^{*5} ^{*7} Leakage current: 5 mA max.	--- ^{*6}

*1. The inrush current may vary depending on the operating condition and other conditions. Therefore, select fuses, breakers, and external power supply devices that have enough margin in characteristic and capacity, considering the condition under which the devices are used.

*2. If the ambient temperature is higher or the Controller is hot-started, the inrush current given in the table may be exceeded by up to twice the given value because the thermistor element with a low-temperature current control characteristic is not sufficiently cool.

*3. Of the inrush current values, the latter value varies depending on the input voltage and may rise to approx. 8.3 A at 20.4 VDC.

*4. Internal components in the Power Supply Unit will deteriorate or be damaged if the Power Supply Unit is used for an extended period of time exceeding the power supply output capacity or if the outputs are shorted.

- *5. Apply the voltage between the Power Supply Unit's L1 or L2 terminal and the GR terminal when testing insulation and dielectric strength. The tests can also be performed with the LG terminal and GR terminal connected to each other. In this case, the leakage current will be 10 mA or less.
- *6. The primary DC power supply and the secondary DC power supply are not isolated.
- *7. Change the applied voltage gradually using the adjuster on the Tester. If the full dielectric strength voltage is applied or turned OFF using the switch on the Tester, the generated impulse voltage may damage the Power Supply Unit.



Precautions for Safe Use

Do not use the Power Supply Units in the system beyond the rated supply capacity range given in the specifications.

Doing so may result in operation stopping, incorrect operation, or failure to correctly back up required data at power interruptions.

3-3-2 Part Names and Functions

NX7-series Power Supply Units

- Front View

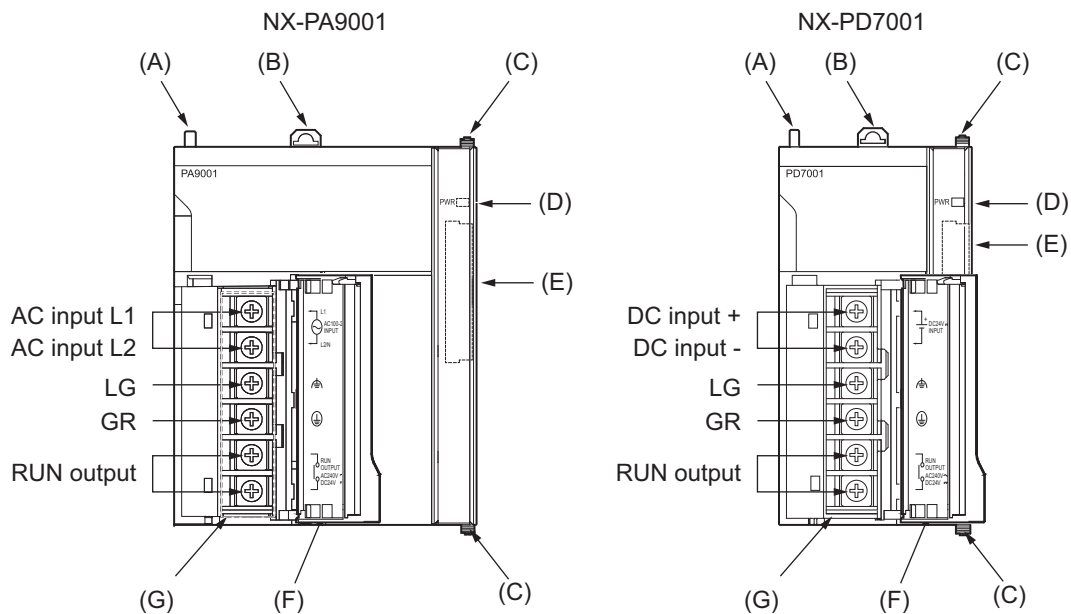

- Back View
Common in NX-PA9001/PD7001

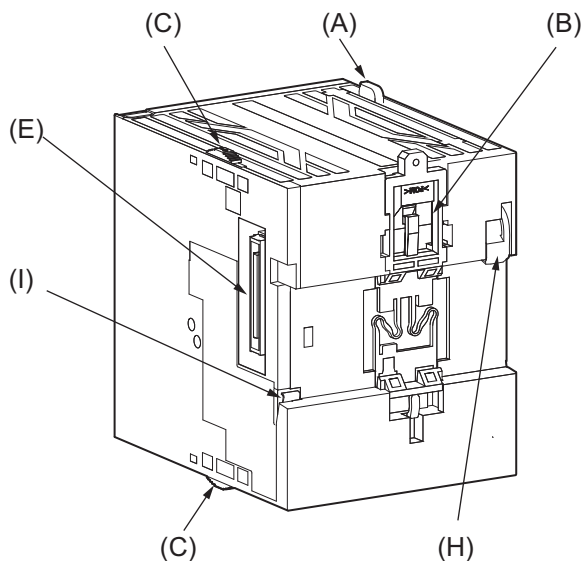

Letter	Name	Function
A	Dropout prevention lock release lever	Releases the dropout prevention lock.
B	DIN Track mounting hooks	These hooks are used to mount the Unit to a DIN Track.
C	Sliders	Holds the Units together.
D	PWR indicator	Indicates that the power supply is operating.
E	Connector	Connects to the CPU Unit.
F	Terminal block cover	Covers the terminal block.
G	Terminal block	The terminal block is used to connect to the power supply.
H	Dropout prevention lock	Prevents the CPU Unit and other devices from accidentally dropping out, when you remove them from the DIN Tracks.
I	DIN Track contact plate	This plate is used to contact the protective ground terminal with a DIN Track.

● Terminal Block

Terminal number	Appearance	Name	Function	
			NX-PA9001	NX-PD7001
(1)		Power supply input	Supply 100 to 240 VAC.*1	Supply 24 VDC.*1
(2)			Ground to a resistance of 100 Ω or less to increase noise resistance and avoid electric shock.*2	Turns ON when the CPU Unit is operating.*3
(3)		LG		
(4)		GR		
(5)		RUN Out-put		
(6)				

*1. For details, refer to 4-4-1 Power Supply Wiring on page 4-31.

*2. For details, refer to 4-4-2 Grounding on page 4-35.

*3. Details of the operation are given in the following table.

Status	Operation
In operation (RUN mode).	ON
The CPU Unit is starting (until entering the operating status that is specified in the Startup Mode setting).	OFF
Operation stopped (PROGRAM mode).	
Controller error in the major fault level occurred.	

3-4 Sysmac Studio

The Sysmac Studio is a Support Software package that provides an integrated development environment to design, program, debug, and maintain SYSMAC NJ/NX-series Controllers.

This section describes the models and connecting methods of the Sysmac Studio.

3-4-1 Model Numbers

The model numbers of the Sysmac Studio Standard Edition are given in the following table. The model numbers are different for the media and licenses.

Product	Configuration software	Media	Number of user licenses	Model
Sysmac Studio Standard Edition	Sysmac Studio	DVD	---	SYSMAC-SE200D
	The following Support Software is also included. Network Configurator CX-Integrator CX-Protocol CX-Designer	Licenses	1	SYSMAC-SE201L
			3	SYSMAC-SE203L
			10	SYSMAC-SE210L

3-4-2 Connection

With an NJ/NX-series CPU Unit, you can connect the Sysmac Studio online in the following ways.

Configuration

● Connecting by USB

- Direct Connection

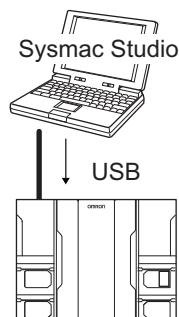

The connection device does not need to be specified.

Note Connect a computer and the CPU Unit with a USB 2.0 certified cable. Do not use a USB hub to connect them.

- Connection to CPU Unit on EtherNet/IP with USB

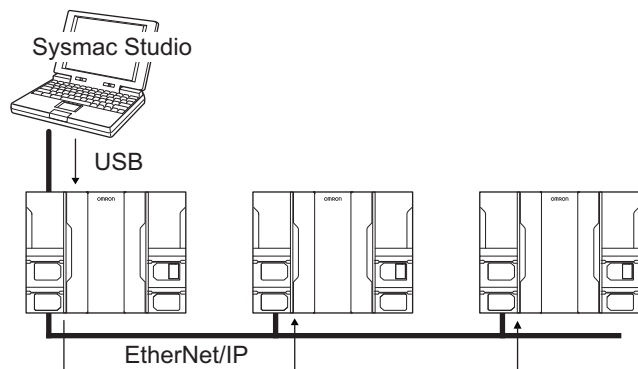

Directly specify the IP address of the remote device or select the remote device from the node list.

● Connection with EtherNet/IP

• 1:1 Connection

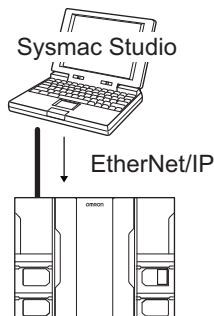

• 1:N Connection

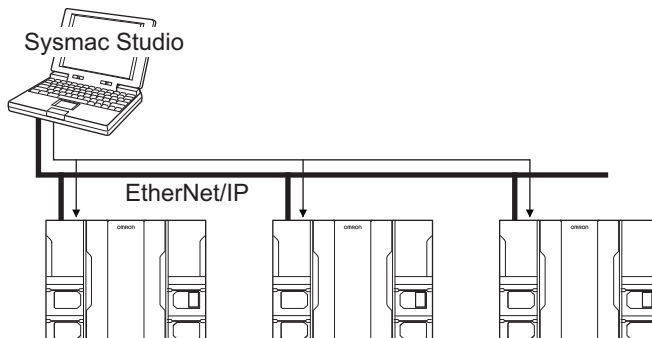

- A direct connection is made from the Sysmac Studio. The IP address and connection device do not need to be specified.*1
- You can make the connection whether or not a switching hub is used.
- Support for Auto-MDI enables the use of cross cables or straight cables if a direct connection is made.

Directly specify the IP address of the remote device or select the remote device from the node list.

*1. With the NX7-series CPU Unit, it is possible only when you connect the Unit to the built-in EtherNet/IP port (port 1).



Additional Information

The Sysmac Studio cannot connect online to an NJ/NX-series CPU Unit in the following type of configuration.

- If the built-in EtherNet/IP port is not used, you cannot connect to an NJ/NX-series CPU Unit on an EtherNet/IP network.

Example: Connection to NJ/NX-series CPU Unit Routing through an EtherNet/IP Unit or Built-in Port

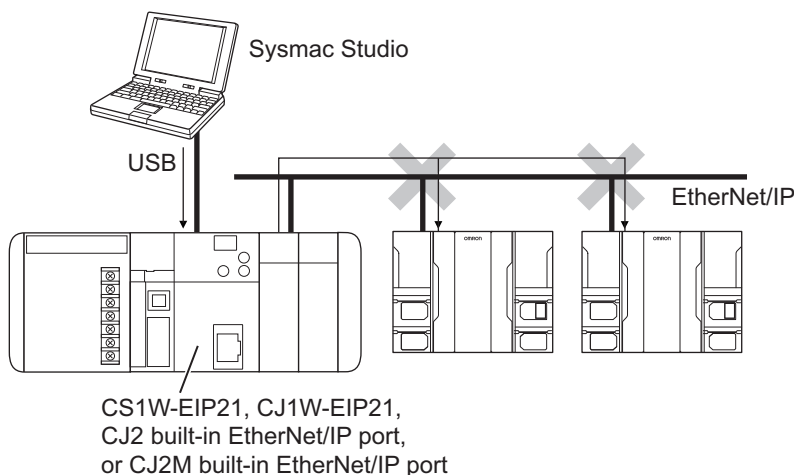

- You cannot route through any networks other than EtherNet/IP networks.

4

Installation and Wiring

This section describes how to install and wire the NX-series CPU Unit as well as details on installation locations.

4

4-1	Processing at Power ON and Power OFF	4-2
4-1-1	Power ON Operation	4-2
4-1-2	Power OFF Operation	4-3
4-1-3	Resetting the Controller from the Sysmac Studio	4-5
4-2	Fail-safe Circuits	4-6
4-2-1	Order of Powering Up the Controller and Controlled System	4-7
4-3	Mounting Units	4-9
4-3-1	Installation in a Control Panel	4-10
4-3-2	Preparations for Installation	4-14
4-3-3	Installing the CPU Module	4-16
4-3-4	Mounting the End Cover	4-20
4-3-5	Mounting the End Plates	4-21
4-3-6	Installing and Removing the SD Memory Card	4-23
4-3-7	Removing the CPU Module	4-27
4-3-8	Assembled Appearance and Dimensions	4-29
4-4	Wiring	4-31
4-4-1	Power Supply Wiring	4-31
4-4-2	Grounding	4-35
4-4-3	Wiring the Built-in EtherCAT Port	4-38
4-4-4	Wiring the Built-in EtherNet/IP Port	4-38
4-5	Control Panel Installation	4-39
4-5-1	Temperature	4-39
4-5-2	Humidity	4-41
4-5-3	Vibration and Shock	4-41
4-5-4	Atmosphere	4-41
4-5-5	Electrical Environment	4-42
4-5-6	Grounding	4-46

4-1 Processing at Power ON and Power OFF

⚠ WARNING

- Do not touch the terminal section while power is ON. Electrical shock may occur.
- Do not disassemble any of the Units. Particularly the Power Supply Units contain parts with high voltages when power is ON or immediately after power is turned OFF. Electrical shock may occur. There are also sharp internal parts that may cause injury.



4-1-1 Power ON Operation



Precautions for Safe Use

It takes approximately 10 to 20 seconds to enter RUN mode after the power supply is turned ON. The outputs during this period will behave according to the slave and Unit specifications. Use the RUN output on the Power Supply Unit, for example, to implement fail-safe circuits so that external devices do not operate incorrectly.

Operation until Operation Ready Status

Once power supply to the Power Supply Unit starts, approximately 10 to 20 seconds elapses before the CPU Unit enters the operation-ready status. This period is called the *startup* status. The *startup* time depends on the slave/Unit configuration^{*1}, user program, SD Memory Card usage, SD Memory Card self-diagnosis usage^{*2}, etc.

While the CPU Unit is in the startup status, the RUN indicator flashes at a one second interval.

- *1. Some EtherCAT slaves can set a maximum standby time of 1 to 200 seconds. For the CPU Unit, however, the operation-ready status exists as soon as the EtherCAT Master Function Module is functioning, regardless of the standby time of the EtherCAT slaves. For the EtherCAT Master Function Module, slaves that do not start within the maximum waiting time are treated as having an error.
- *2. This function performs self-diagnosis on the inserted SD Memory Card. This is executed if the self-diagnosis at startup is enabled in the **Operation Settings** under **Configurations and Setup – Controller Setup** in the Sysmac Studio.

The following processing is performed during the *startup* status.

Process	Description
Self diagnosis at startup	Operation is monitored for the following errors: <i>Power Supply Error, CPU Unit Reset, CPU Unit Watchdog Timer Error</i> . ^{*1}
Data check	The <i>_RetainFail</i> (Retention Failure Flag) system-defined variable changes to TRUE when the values of variables for which the Retain attribute was set to retain the values were not retained after a power interruption.
Recording Power Turned ON and Power Interrupted events	The Power Turned ON and Power Interrupted events are recorded.

*1. Refer to 5-1-2 *Fatal Errors in the CPU Unit* on page 5-3 for information on the following errors: *Power Supply Error, CPU Unit Reset, and CPU Unit Watchdog Timer Error*.

Operating Mode at Startup

The system will immediately enter RUN mode if RUN mode (default) is set as the startup operating mode. The system will immediately enter PROGRAM mode if PROGRAM mode is set as the startup operating mode.

• RUN Mode Set as Startup Mode

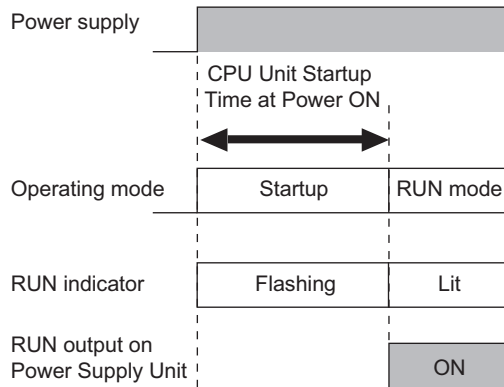

• PROGRAM Mode Set as Startup Mode

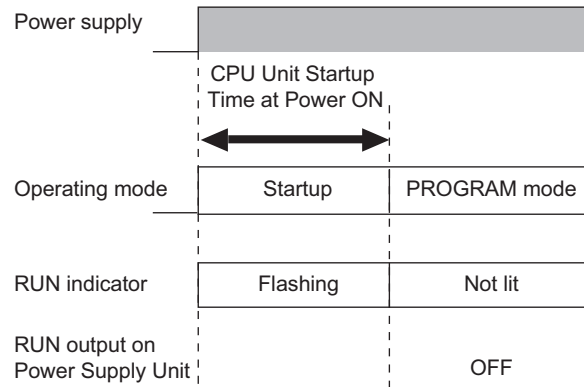

4-1-2 Power OFF Operation

WARNING

The NX-series Controller continues normal operation for a specific period of time even when a momentary power interruption occurs. The Controller may therefore receive incorrect signals from external devices that are affected by the momentary power interruption.

Take suitable actions, such as external fail-safe measures and interlock conditions, to monitor the power supply voltage of the external devices as required.



Different operations will be performed when the power is turned OFF depending on whether the power interruption time is longer than the power OFF detection time, as described below.

The following table gives the voltage conditions for a power interruption.

Power Supply Unit model	Power supply input	Power interruption voltage
NX-PA9001	100 to 200 VAC	85 VAC max.
NX-PD7001	24 VDC	20.4 VDC max.

The setting ranges for the power OFF detection time are given in the following table.

Power supply type	Power OFF detection time
AC power supply	30.5 to 45.5 ms
DC power supply	5.0 to 20.5 ms

Operation at Power OFF Operation

Execution of the user program is ended if a power interruption exceeds the time shown in the table below. The processing after power interruption confirmation (described below) is performed, and then the system (i.e., CPU Unit) stops.

Power supply type	Time required for a power interruption
AC power supply	45.5 ms or longer
DC power supply	20.5 ms or longer

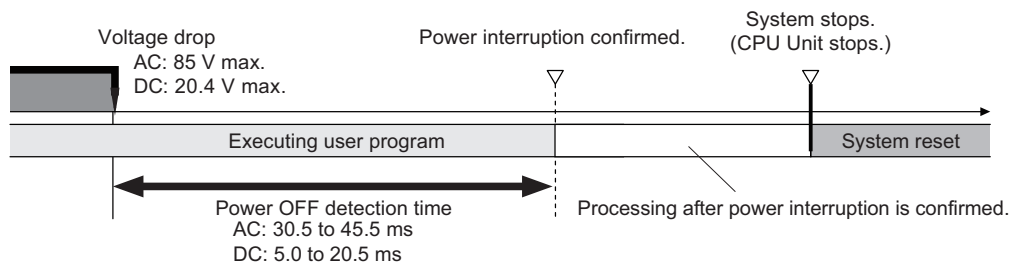

As shown in the following figure, the system (i.e. CPU Unit) will stop even if the voltage recovers after the power interruption detection time.

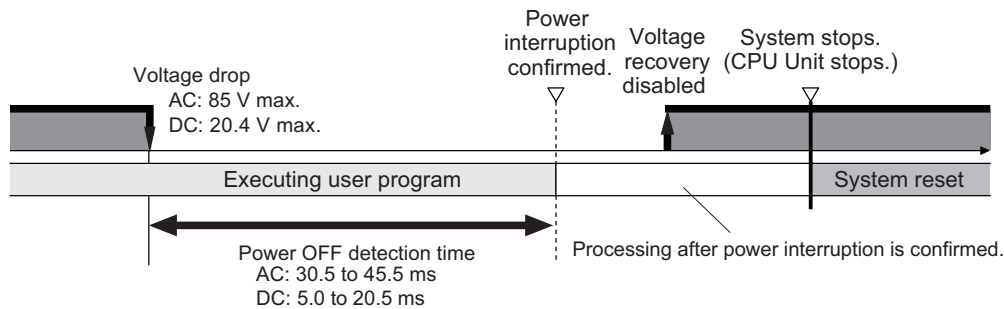

After stopping, the system will restart if the power supply remains recovery.

The table below defines the time that is used in the above two figures.

Item	Description
Power OFF detection time	The time from when the power supply voltage drops until the CPU Unit starts processing after the power interruption is confirmed. The CPU Unit continues to operate normally until the power interruption is confirmed.

Momentary Power Interruption with Continued Operation

Execution of the user program will continue if a momentary power interruption is less than the following times.

Power supply type	Momentary power interruption time with continued operation
AC power supply	30.5 ms max.
DC power supply	5.0 ms max.

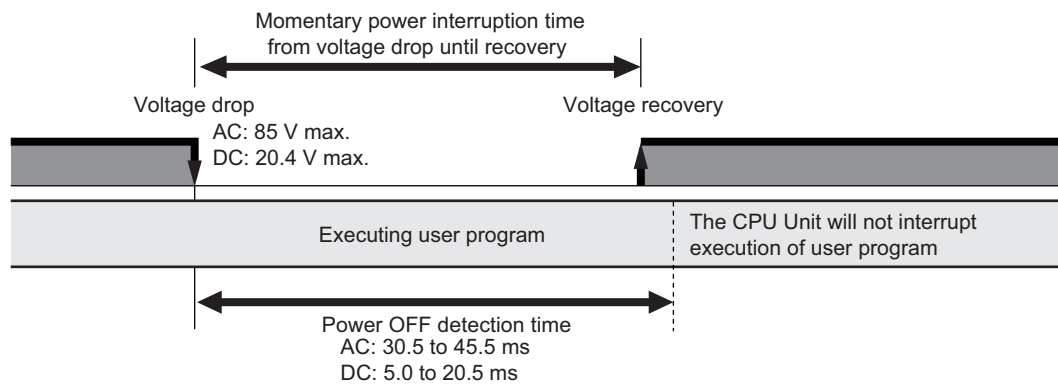

Processing After Power Interruption Is Confirmed

After a power interruption is confirmed, the CPU Unit performs the following processing and then stops.

Item		Description
I/O refresh		Load outputs are turned OFF. Tag data links stop.
Processing	SD Memory Card access in progress	Any writing is interrupted, files are closed, and the Card is unmounted.
	Transferring user program (including online editing)	Interrupted. As a result, an error will occur the next time that the power is turned ON. The Controller will not operate.
	User program execution	User program execution is aborted even during execution of an instruction.
Saving event log		The time that a power interruption occurs and the cause (primary power interruption of Power Supply Unit) of the interruption are recorded.

4-1-3 Resetting the Controller from the Sysmac Studio

You can reset the CPU Unit from the Sysmac Studio.

A reset from the Sysmac Studio performs the same operation as cycling the power supply of the Power Supply Unit.

Resetting is possible, however, only when the CPU Unit is in PROGRAM mode.

Confirm the following status before resetting the CPU Unit.

- Check the status of output loads.
- Make sure that SD Memory Card access is not in progress.

4-2 Fail-safe Circuits

WARNING

Provide safety measures in external circuits to ensure safety in the system if an abnormality occurs due to malfunction of the CPU Unit, other Units, or slaves or due to other external factors affecting operation. Not doing so may result in serious accidents due to incorrect operation.

- Emergency stop circuits, interlock circuits, limit circuits, and similar safety measures must be provided in external control circuits.
- The outputs may remain ON or OFF due to deposition or burning of the output relays or destruction of the output transistors. As a countermeasure for such problems, external safety measures must be provided to ensure safe operation of the system.



• The CPU Unit will turn OFF all outputs from Digital Output Units in the following cases. The slaves will operate according to the settings in the slaves.

- If a power supply error occurs.
- If a CPU error or CPU reset occurs.
- If a Controller error in the major fault level occurs.
- While the CPU Unit is in startup status until RUN mode is entered after the power is turned ON.
- If a system initialization error occurs.



External safety measures must be provided to ensure safe operation of the system in such cases.

- If external power supplies for slaves or other devices are overloaded or short-circuited, the voltage will drop, outputs will turn OFF, and the system may be unable to read inputs. Provide external safety measures in controls with monitoring of external power supply voltage as required so that the system operates safely in such a case.
- Unintended outputs may be performed when an error occurs in variable memory. As a countermeasure for such problems, external safety measures must be provided to ensure safe operation of the system.
- Provide measures in the communications system and user program to ensure safety in the overall system even if errors or malfunctions occur in data link communications or remote I/O communications.
- If a communications interference occurs for remote I/O or if a major fault level error occurs, output status will be determined by the specifications of the external output device. Confirm the operating specifications for communications errors and major fault level errors and implement suitable safety measures. Correctly set all of the settings in the slaves and Units.
- You must implement fail-safe circuits to provide sufficient protection in the event that abnormal signals occur as the result of broken signal lines or momentary power interruptions. Not doing so may result in serious accidents due to incorrect operation.



4-2-1 Order of Powering Up the Controller and Controlled System

Outputs from Units, such as DC Output Units, may malfunction momentarily when the power to the Controller is turned ON. This may cause problems in the system if the Controller power supply is turned ON after the controlled system's power supply. To prevent possible malfunctions, add an external circuit that prevents the power supply to the controlled system from going ON before the power supply to the Controller itself.



Precautions for Safe Use

It takes approximately 10 to 20 seconds to enter RUN mode after the power supply is turned ON. During that time, outputs will be OFF or the values will be according to settings in the Units or slaves. Also, external communications cannot be performed.

Use the RUN output on the Power Supply Unit, for example, to implement fail-safe circuits so that external devices do not operate incorrectly.

Output Unit Failure

It is possible for an output to remain ON due to a malfunction in the internal circuitry of the Output Unit, such as a relay or transistor malfunction. Be sure to add any circuits necessary outside of the Controller to ensure the safety of the system in the event that an output fails to go OFF.

Power Supply Wiring and Emergency Stop Circuit

The following emergency stop circuit controls the power supply to the controlled system so that power is supplied to the controlled system only when the Controller is operating and the RUN output is ON. An external relay (CR1) is connected to the RUN output from the Power Supply Unit as shown in the following diagram.

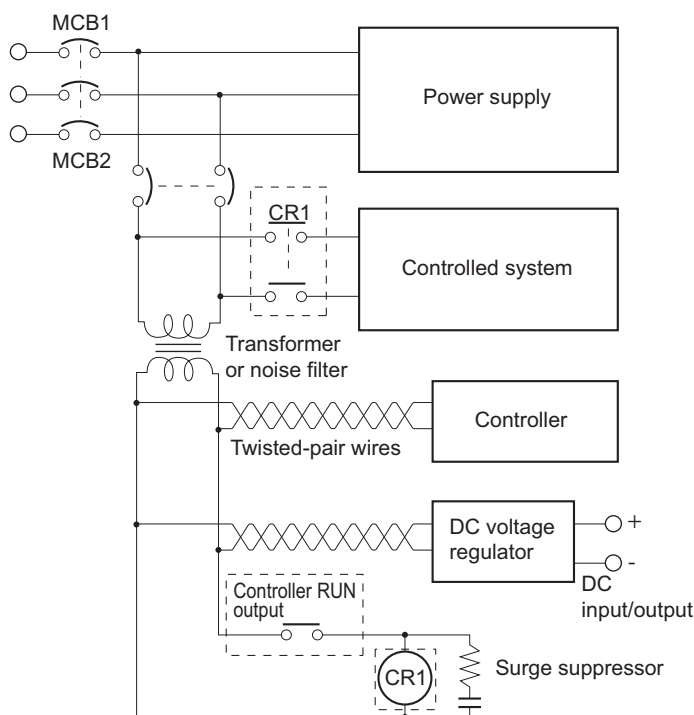

Interlock Circuits

When the Controller controls an operation such as the clockwise and counterclockwise operation of a motor, provide an external interlock such as the one shown in the following example to prevent both the forward and reverse outputs from turning ON at the same time if required by the application.

Example:

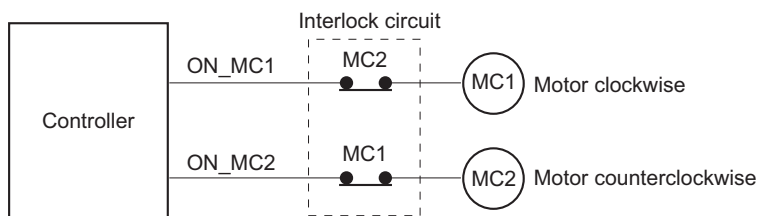

This circuit prevents outputs MC1 and MC2 from both being ON at the same time even if both Controller outputs ON_MC1 and ON_MC2 are ON due to a malfunction.

4-3 Mounting Units

This section describes how to mount Units to the NX-series Controller.

In this description, the combination of the NX-series CPU Unit and the NX-series Power Supply Unit is called a CPU Module.



Precautions for Safe Use

- Always turn OFF the power supply to the Controller before attempting any of the following.
 - Mounting or removing NX Units or CPU Units.
 - Assembling the Units.
 - Setting DIP switches or rotary switches.
 - Connecting cables or wiring the system.
 - Connecting or disconnecting the connectors.
 - Mounting or removing the Fan Unit.
- The Power Supply Unit continues to supply power to the Controller for up to several seconds after the power supply is turned OFF. The PWR indicator remains lit as long as power is supplied. Make sure that the PWR indicator is not lit before you perform any of the above operations.



Precautions for Correct Use

- Follow the instructions in this manual to correctly perform installation.
- Do not operate or store the Units in the following locations. Doing so may result in malfunction or in operation stopping.
 - Locations subject to direct sunlight
 - Locations subject to temperatures or humidity outside the range specified in the specifications
 - Locations subject to condensation as the result of severe changes in temperature
 - Locations subject to corrosive or flammable gases
 - Locations subject to dust (especially iron dust) or salts
 - Locations subject to exposure to water, oil, or chemicals
 - Locations subject to shock or vibration
- Take appropriate and sufficient countermeasures during installation in the following locations.
 - Locations subject to strong, high-frequency noise
 - Locations subject to static electricity or other forms of noise
 - Locations subject to strong electromagnetic fields
 - Locations subject to possible exposure to radioactivity
 - Locations close to power lines

4-3-1 Installation in a Control Panel

Installation in Cabinets or Control Panels

When the NX-series Controller is being installed in a cabinet or control panel, be sure to provide proper ambient conditions as well as access for operation and maintenance.

● Temperature Control

The ambient temperature within the NX-series Controller must be within the operating range of 0 to 55°C. When necessary, take the following steps to maintain the proper temperature.

- Provide enough space for good air flow.
- Do not install the Controller directly above equipment that generates a large amount of heat such as heaters, transformers, or high-capacity resistors.
- If the ambient temperature exceeds 55°C, install a cooling fan or air conditioner.

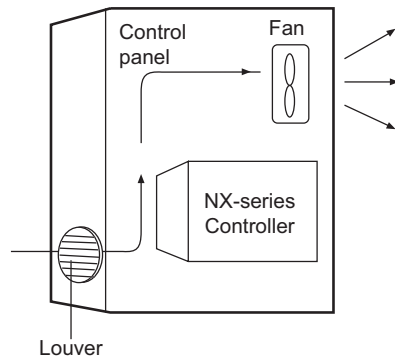

● Accessibility for Operation and Maintenance

- To ensure safe access for operation and maintenance, separate the Controller as much as possible from high-voltage equipment and power machinery.
- It will be easy to operate the Controller if it is mounted at a height of 1.0 to 1.6 m above the floor.

● Improving Noise Resistance

- Do not mount the Controller in a control panel containing high-voltage equipment.
- Install the Controller at least 200 mm away from power lines.

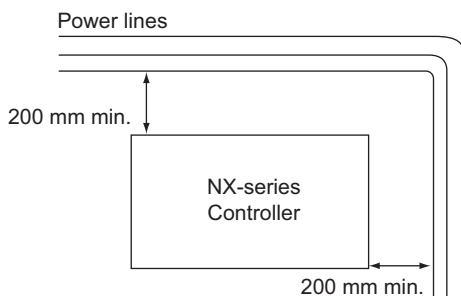

- Ground the mounting plate between the Controller and the mounting surface.

● Controller Orientation

- Each Rack must be mounted in an upright position to provide proper cooling.

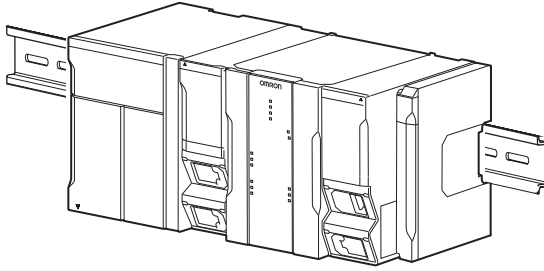

- Do not install a Rack in any of the following positions.

Mounting with the DIN Track on the Bottom

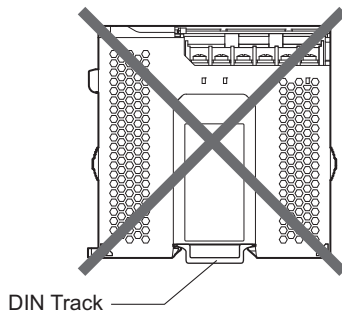

Mounting with the DIN Track on the Top

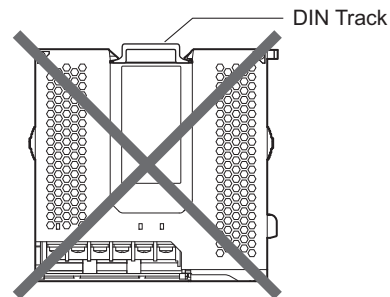

Mounting with the DIN Track Installed Vertically

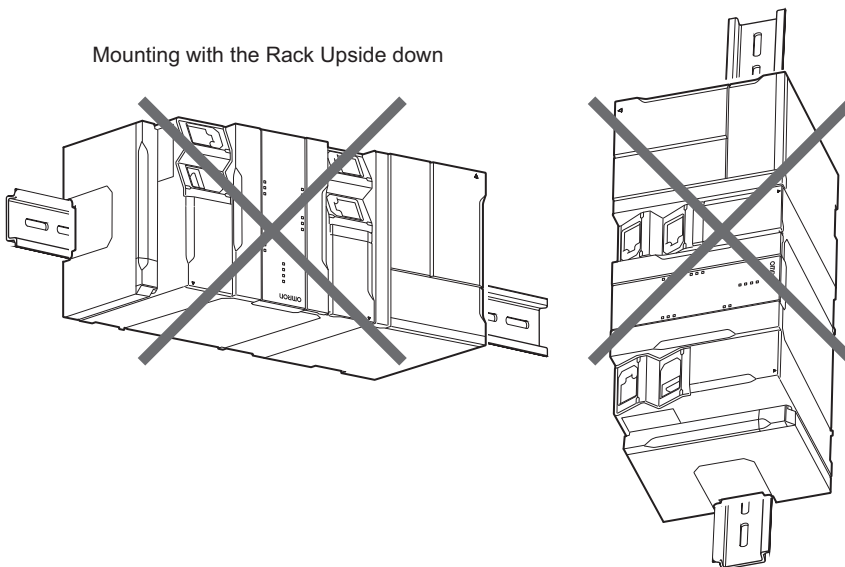

Mounting with the Rack Upside down

Installation Method in Control Panels

An NX-series Controller must be mounted inside a control panel on DIN Track.

- Consider the width of wiring ducts, wiring, ventilation, and Unit replacement when determining the space between the CPU Rack and other devices.



Additional Information

A Controller must be mounted on DIN Track.

It cannot be mounted with screws.

● **Wiring Ducts**

Whenever possible, route I/O wiring through wiring ducts.

Install mounting bracket so that it is easy to fish wire from the I/O Units through the duct. It is handy to have the duct at the same height as the CPU Rack.

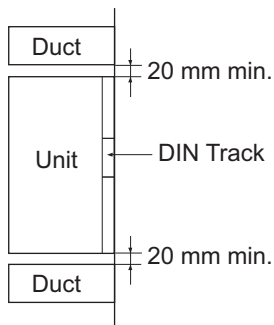

Additional Information

If you want to attach or remove the Fan Unit of CPU Unit while the CPU Rack remains mounted on the control panel, ensure at least 50 mm between the tops of CPU Unit and the wiring duct.

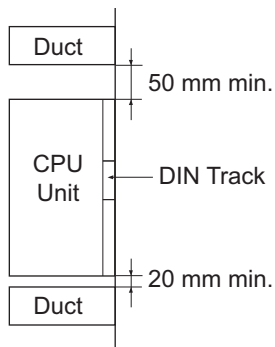

● **Wiring Duct Example**

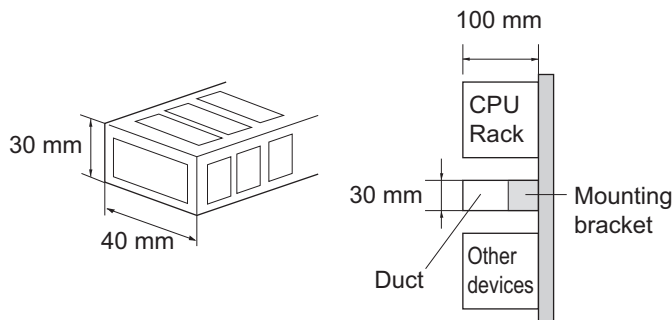



Precautions for Correct Use

Tighten terminal block screws and cable screws to the following torques.

Terminal Screws

M4: 1.2 N·m

M3: 0.5 N·m

Cable Connector Screws

M2.6: 0.2 N·m

● Routing Wiring Ducts

Install the wiring ducts at least 20 mm away from the tops of the Rack and any other objects (e.g., ceiling, wiring ducts, structural supports, devices, etc.) to provide enough space for air circulation and replacement of Units.

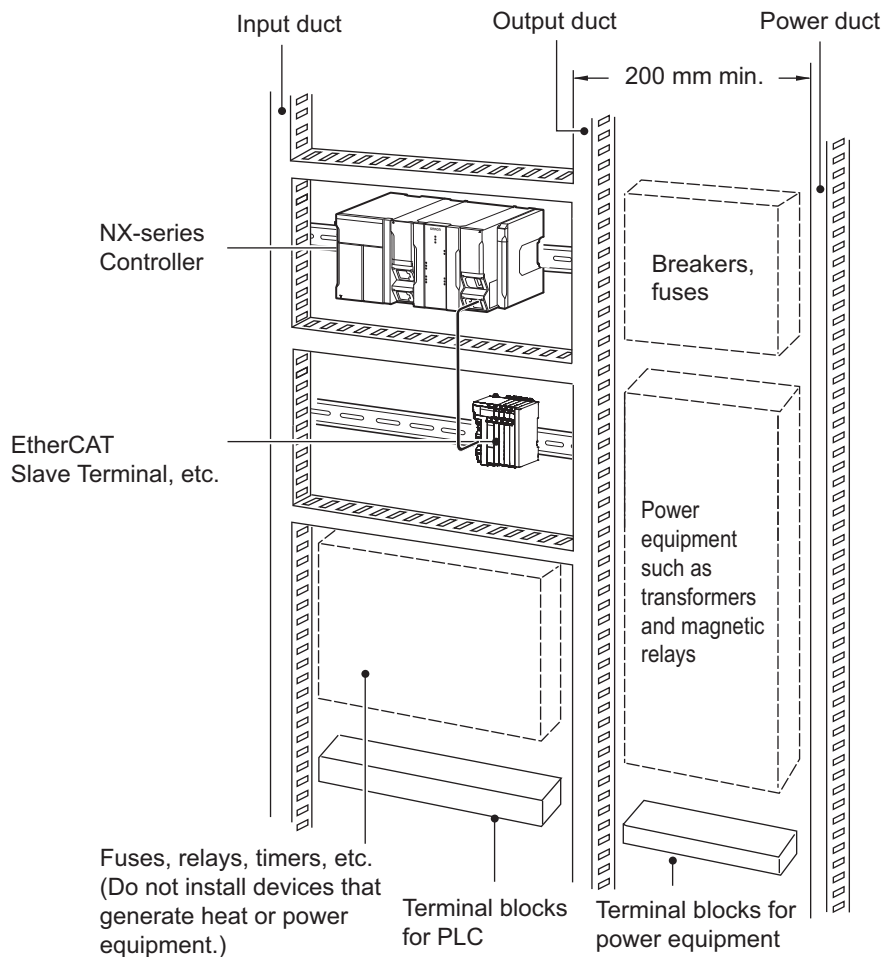

4-3-2 Preparations for Installation

We recommend using the following products to install the Unit on a DIN Track.

Name	Model	Manufacturer	Remarks
35-mm DIN Track	PFP-50N	OMRON Corporation	<ul style="list-style-type: none"> Length: 50 cm Material: Aluminum Surface treatment: Insulated
	PFP-100N	OMRON Corporation	<ul style="list-style-type: none"> Length: 100 cm Material: Aluminum Surface treatment: Insulated
	NS 35/ 7,5 PERF	Phoenix Contact	<ul style="list-style-type: none"> Length: 75.5, 95.5, 115.5, or 200 cm Material: Steel Surface treatment: Conductive
	NS 35/ 15 PERF	Phoenix Contact	<ul style="list-style-type: none"> Length: 75.5, 95.5, 115.5, or 200 cm Material: Steel Surface treatment: Conductive
End Plate	PFP-M	OMRON Corporation	Two End Plates are required for each CPU Rack.
	CLIPFIX 35	Phoenix Contact	Two End Plates are required for each CPU Rack.

Not all of the combinations of the DIN Tracks and End Plates listed above are possible.

Confirm applicability of the combinations in the following table.

DIN Track model	PFP-M (OMRON)	CLIPFIX 35 (Phoenix Contact)
PFP-50N	Possible.	Possible.
PFP-100N	Possible.	Possible.
NS 35/ 7,5 PERF	Possible.	Possible.
NS 35/ 15 PERF	Not possible.	Possible.

Also, use screws and washers of the following sizes to fix the DIN Tracks.

(a): Dimensions from the screw head to the fastening surface

DIN Track model	Applicable screw size	(a)
PFP-50N	M4	4.1 mm max.
NS 35/ 7,5 PERF	M6	4.6 mm max.
NS 35/ 15 PERF	M6	10 mm max.

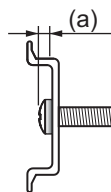

If you use any DIN Track other than those listed in the table above, refer to the dimensions shown in 4-3-8 Assembled Appearance and Dimensions on page 4-29 and use proper screws and washers.

● **DIN Tracks**

PFP-100N/50N DIN Track

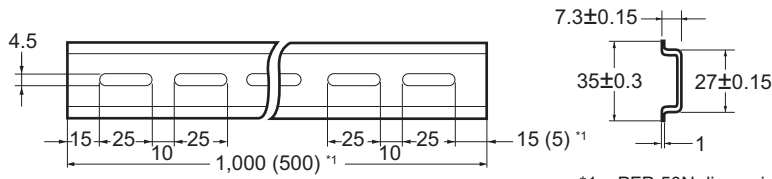

*1. PFP-50N dimensions are given in parentheses.

NS 35/ 7,5 PERF

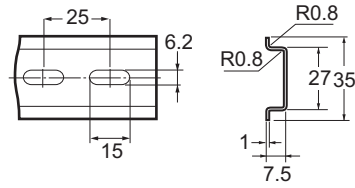

NS 35/ 15 PERF

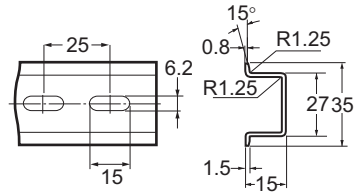

● **End Plate**

PFP-M (Two)

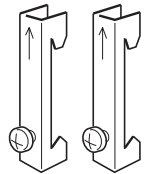

CLIPFIX 35 (Two)

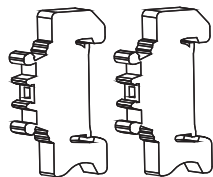

4-3-3 Installing the CPU Module

This section describes how to install the CPU Module.



Precautions for Safe Use

- Do not apply labels or tape to the Unit. When the Unit is installed or removed, adhesive or scraps may adhere to the pins in the NX bus connector, which may result in malfunctions.
- Do not touch the pins in the NX bus connector on the Unit. Dirt may adhere to the pins in the NX bus connector, which may result in malfunctions.

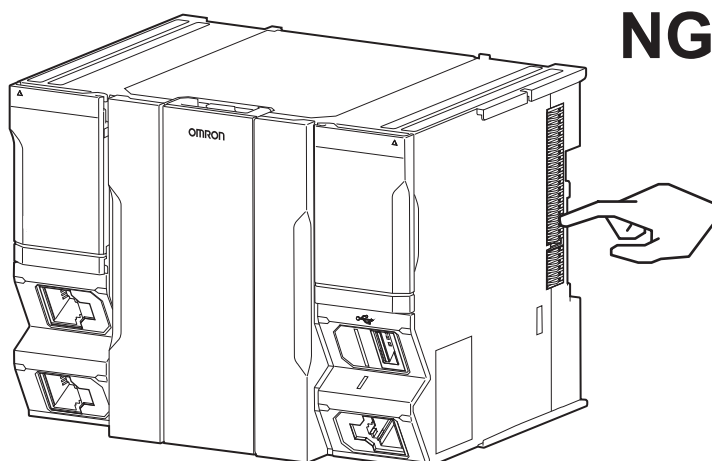

- Do not write on the CPU Unit with ink within the restricted region that is shown in the following figure. Also do not get this area dirty. When the Unit is installed or removed, ink or dirt may adhere to the pins in the NX bus connector, which may result in malfunctions in the Unit.

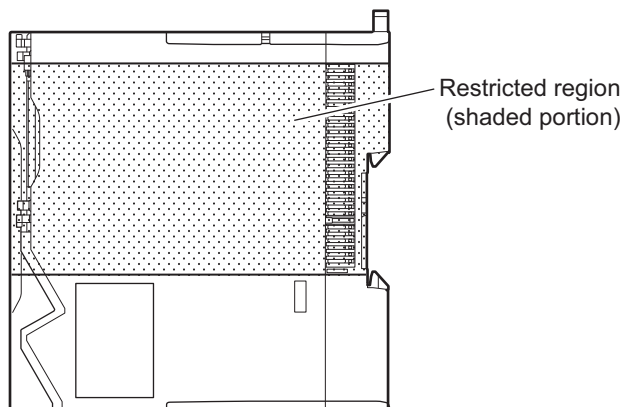

Precautions for Correct Use

- When you install the Unit, be careful not to touch or bump the pins in the NX bus connector.
- When you handle the Unit, be careful not to apply stress to the pins in the NX bus connector. If the Unit is installed and the power supply is turned ON when the pins in the NX bus connector are deformed, contact failure may cause malfunctions.

1 Install the DIN Track.

- Using a PFP-50N/100N DIN Track

Use one M4 screw for each three holes in the DIN Track. There must be a screw for each interval of 105 mm or less. The screw tightening torque is 1.2 N·m.

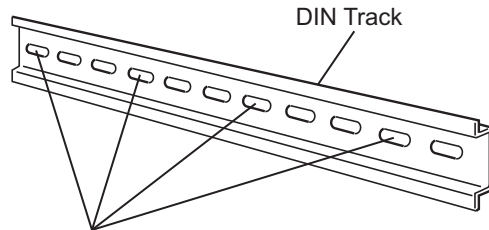

Use one screw for each three holes.

- Using an NS 35/ 7,5 PERF or NS 35/ 15 PERF DIN Track

Use one M6 screw for each four holes in the DIN Track. There must be a screw for each interval of 100 mm or less. The screw tightening torque is 5.2 N·m.

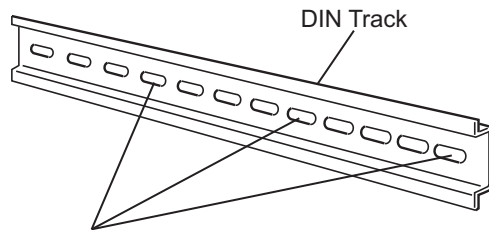

Use one screw for each four holes.

2 Connect the Power Supply Unit and the CPU Unit and lock them with the sliders.

- (1) Join the Units so that the connectors fit exactly.
- (2) The yellow sliders one each at the top and bottom of each Unit lock the Units together. Move the sliders toward the back of the Units as shown below until they click into place.

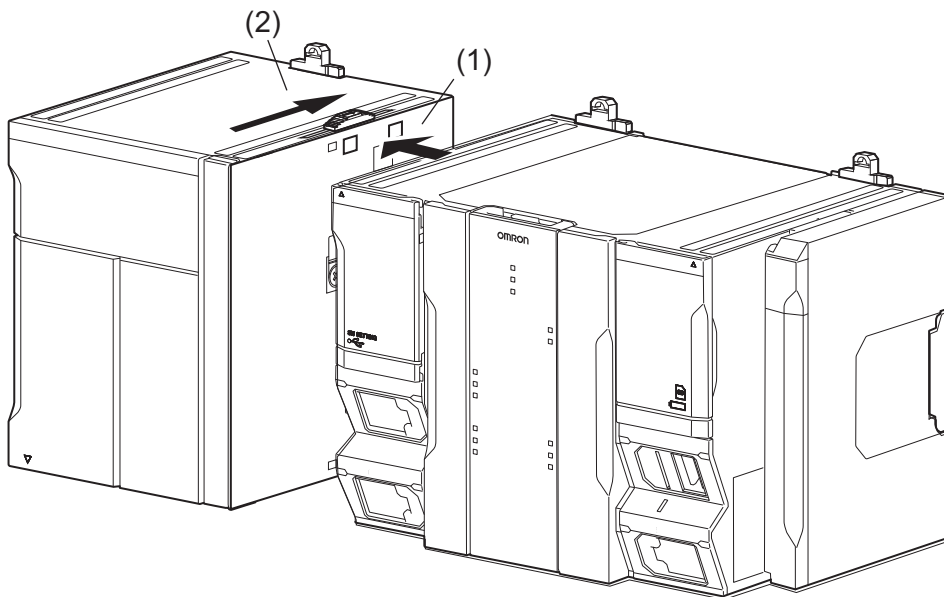

- 3** Make sure that the DIN Track mounting hooks on each Unit of the CPU Module are in the unlocked position.

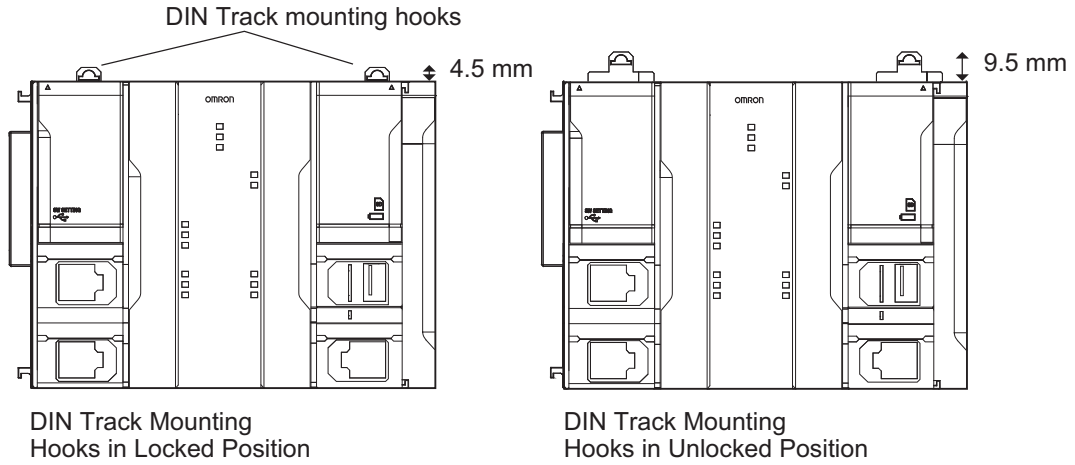

If the DIN Track mounting hooks are pulled up, they are in the unlocked position.

If the DIN Track mounting hooks are pressed down, they are in the locked position.

Use a flat-blade screwdriver to pull up the DIN Track mounting hook on the Unit to release the locked position.

- 4** Mount the CPU Module on the DIN Track and lock it.
 (1) Press the CPU Module straight against the DIN Track.

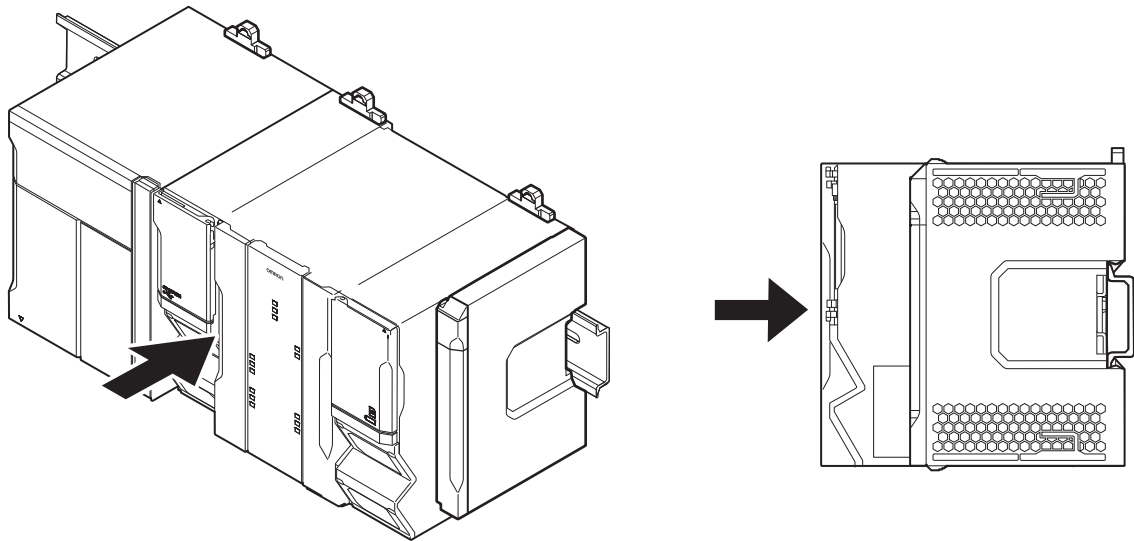

- (2) Press the DIN Track mounting hooks down to the locked position.

After mounting, check to be sure that the CPU Module and the End Cover securely mounted on the DIN Track.

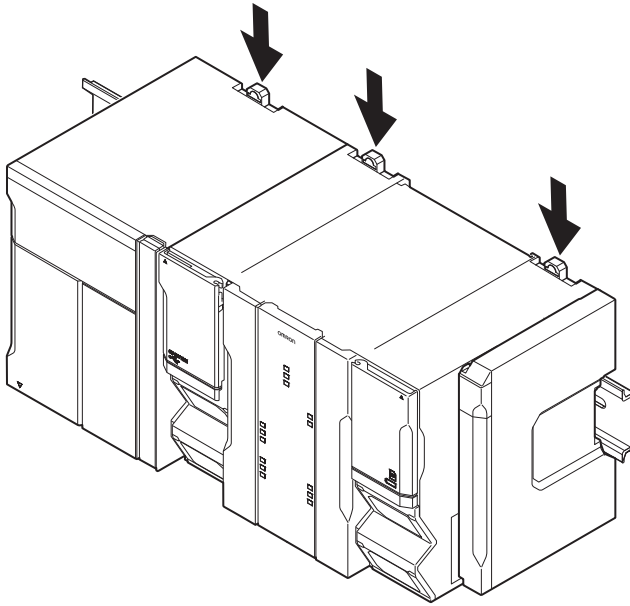

4-3-4 Mounting the End Cover

Use the following procedure to mount the End Cover if you removed it when mounting the Unit or if it is displaced from the CPU Unit.



Precautions for Correct Use

Always mount an End Cover to the end of the CPU Rack to protect the last Unit on the CPU Rack. Not mounting the End Cover may result in malfunction or failure of the CPU Unit.

- 1 From the front of the CPU Unit, slide the End Cover along the Unit hookup guides on the Unit.

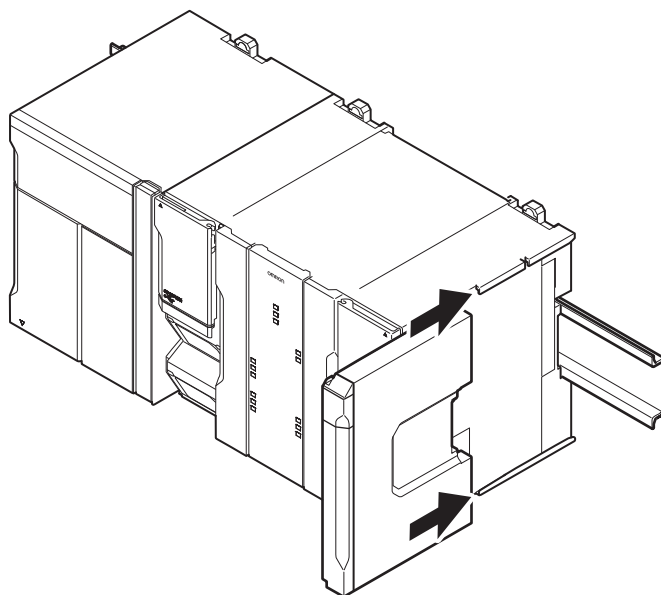

- 2 Press the End Cover firmly against the DIN Track until you hear it lock into place on the DIN Track.
After you mount the End Cover, check to be sure that it is securely mounted on the DIN Track.

4-3-5 Mounting the End Plates

After you mount the End Cover, always secure the Unit with End Plates at both sides.



Precautions for Correct Use

After you mount the Unit on the DIN Track, always secure it with End Plates at both sides. If you do not secure it, the Unit may be damaged or malfunction.

● Using PFP-M (OMRON)

To mount an End Plate, 1) hook the bottom of it on the bottom of the DIN Track and 2) rotate the End Plate to hook the top of it on the top of the DIN Track.

Then tighten the screw to lock the End Plate in place.

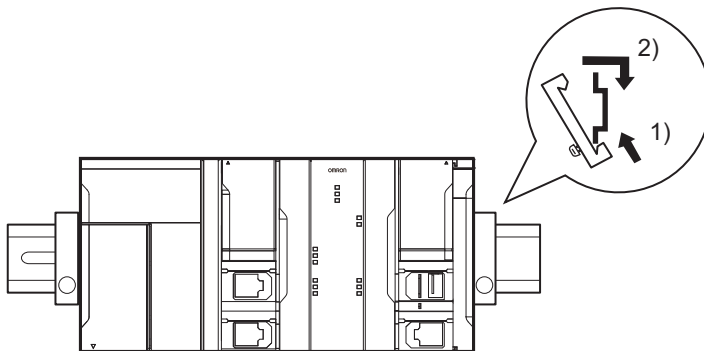

● Using CLIPFIX 35 (Phoenix Contact)

To mount an End Plate, 1) hook the top of it on the top of the DIN Track and 2) rotate the Plate to hook the bottom of it on the bottom of the DIN Track. Press in until you hear the End Plate lock into place.

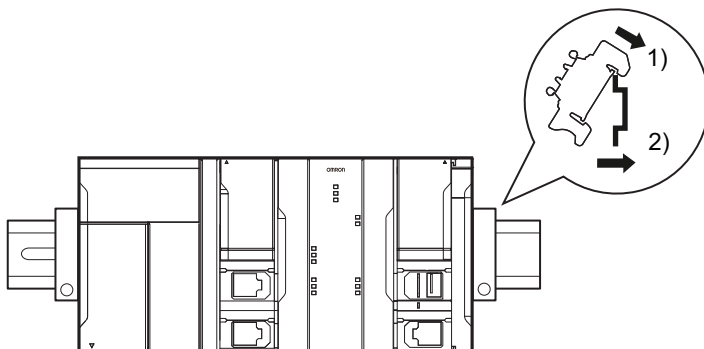

To remove an End Plate 1) insert the tip of a flat-blade screwdriver into groove “a” and 2) use “b” as a fulcrum and lift the end of the screwdriver, as shown in the following diagram.

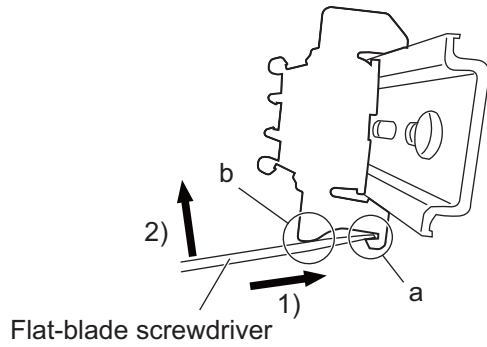

4-3-6 Installing and Removing the SD Memory Card

Before Using an SD Memory Card

- Observe the following precautions while the SD Memory Card is being accessed.
The SD Memory Card may become unusable if these precautions are not followed.
 - a) Make sure that the SD BUSY indicator is OFF (i.e., the SD Memory Card is not being accessed) before you turn OFF the power supply to the Controller.
The SD BUSY indicator is lit when the SD Memory Card is accessed from the user program or from a computer through FTP.
 - b) Never remove the SD Memory Card while the CPU is accessing the SD Memory Card.
Press the SD Memory Card power supply switch and wait for the SD BUSY indicator to go OFF before removing the SD Memory Card.
- Never insert the SD Memory Card facing the wrong way.
If the SD Memory Card is inserted forcibly, it may become unusable.
- To format the SD Memory Card (e.g., to delete all of the data), insert the SD Memory Card in the CPU Unit and perform the operation from the Sysmac Studio.
- The SD Memory Card uses flash memory, and so its service life is limited. When the end of the SD Memory Card's service life approaches, the ability to write data is lost, and data is sometimes not retained after writing. The service life depends on the size of the data that is written and on the ambient temperature. For the unlikely event that data is lost, it is recommended to periodically back up data.
- The service life may be extremely short if a non-OMRON SD Memory Card is used. Also, operation may be affected due to deterioration in writing performance.
- If you use an OMRON SD Memory Card, the end of the life of the SD Memory Card can be detected in the following ways.
 - a) `_Card1Deteriorated` (SD Memory Card Life Warning Flag) system-defined variable
 - b) *SD Memory Card Life Exceeded* event in the event log

Installing the SD Memory Card

- 1** Pull the upper side of the right CPU Unit cover forward and remove from the Unit.

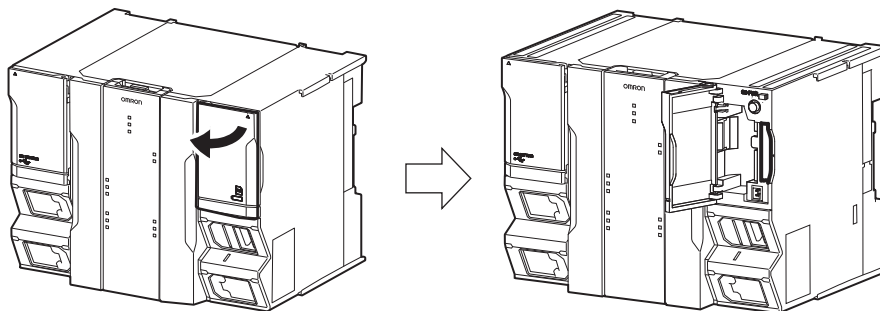

- 2** Insert the SD Memory Card with the label facing to the right.
Insert the SD Memory Card with the label facing the right side of the CPU Unit.

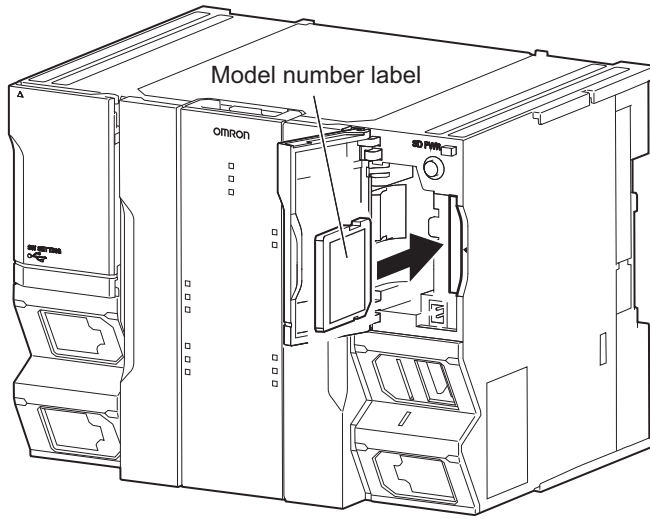

- 3** Push the SD Memory Card securely into the compartment.

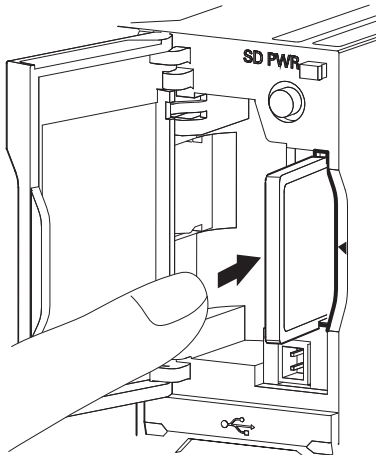

Removing the SD Memory Card

- 1 Press the SD Memory Card power supply switch.

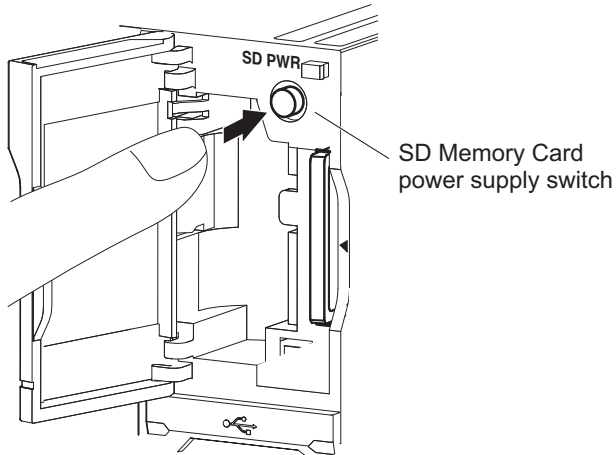

- 2 Press the SD Memory Card after the SD BUSY indicator is no longer lit.

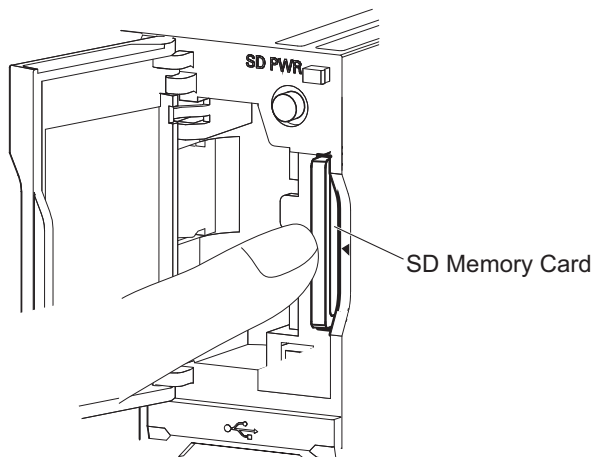

The SD Memory Card will be ejected from the compartment.

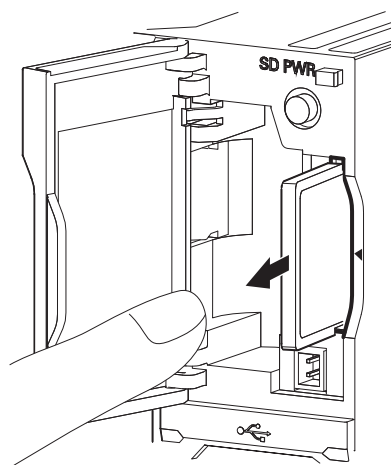

- 3 Pull out the SD Memory Card.

- 4 Close the CPU Unit cover when an SD Memory Card is not being used.

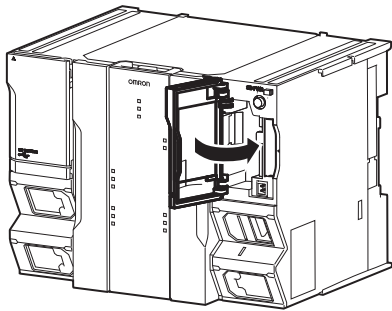

4-3-7 Removing the CPU Module

This section describes how to remove the CPU Module.



Precautions for Safe Use

- Do not apply labels or tape to the Unit. When the Unit is installed or removed, adhesive or scraps may adhere to the pins in the NX bus connector, which may result in malfunctions.
- Do not touch the pins in the NX bus connector on the Unit. Dirt may adhere to the pins in the NX bus connector, which may result in malfunctions.

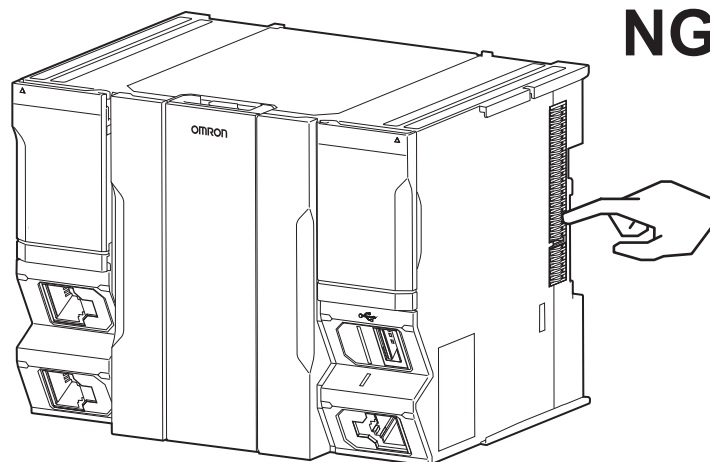

- Do not write on a CPU Unit with ink within the restricted region that is shown in the following figure. Also do not get this area dirty. When the Unit is installed or removed, ink or dirt may adhere to the pins in the NX bus connector, which may result in malfunctions in the Unit.

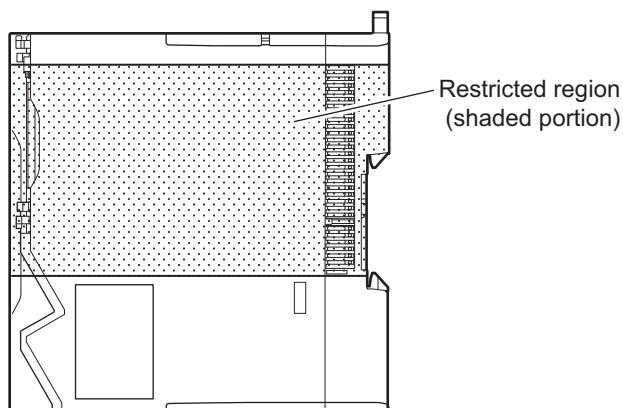

Precautions for Correct Use

When you remove a Unit, be careful not to touch or bump the pins in the NX bus connector.

1 Unlock the DIN Track mounting hook.

Use a flat-blade screwdriver to pull up the DIN Track mounting hook on the CPU Module to unlocked position.

At this point, be sure not to drop the CPU Module.

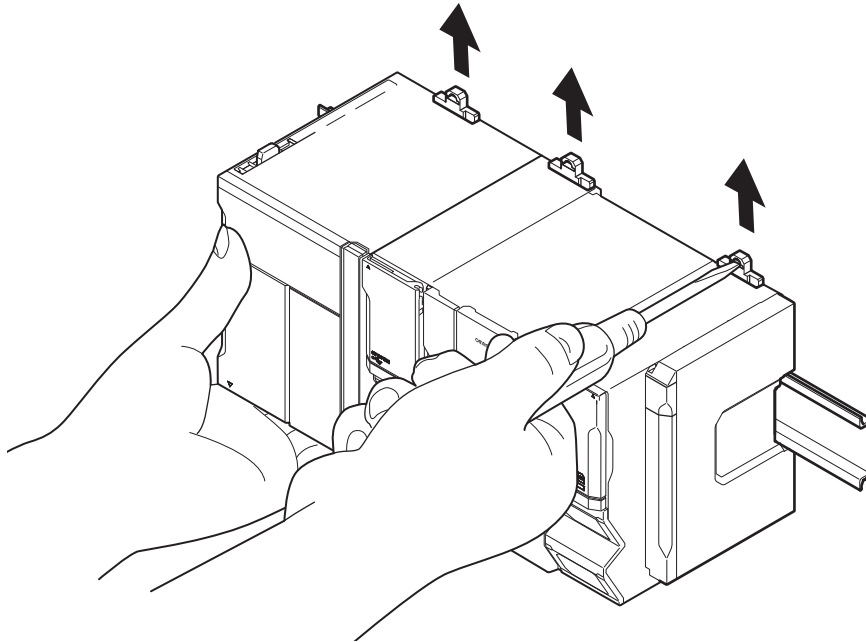

2 Remove the CPU Module from the DIN Track.

(1) Press the dropout prevention lock release lever on the front left side of the Power Supply Unit to release the dropout prevention lock.

(2) Press and hold the release lever, pull the CPU Module straight forward to remove it.

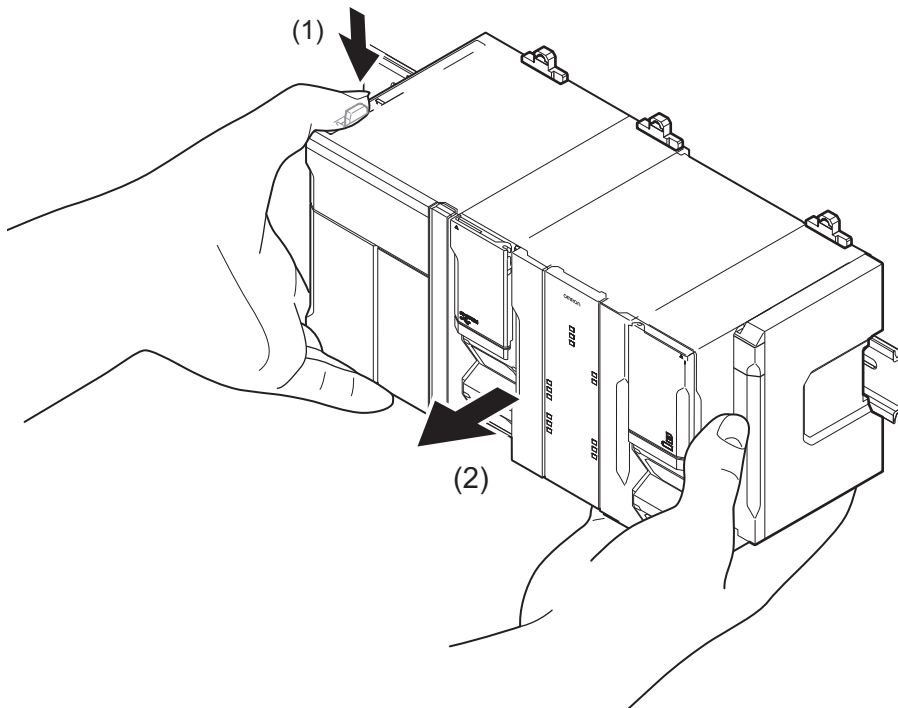

4-3-8 Assembled Appearance and Dimensions

Installation Dimensions

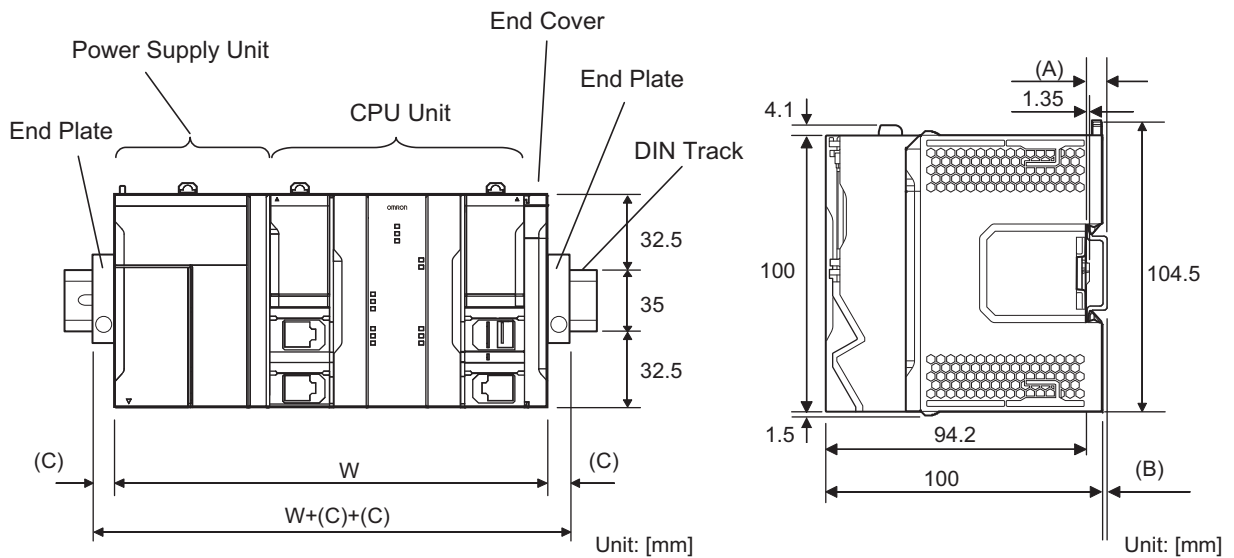

W: Total width of the Power Supply Unit and CPU Unit (the End Cover is included in the CPU Unit width)

- Unit width

Model	Unit width [mm]
NX-PA9001	80
NX-PD7001	51
NX701-1700	144
NX701-1600	144

- DIN Track dimension

DIN Track model	(A) DIN Track dimension	(B) Dimension from the back of the Unit to the back of the DIN Track
PFP-100N	7.3 mm	1.5 mm
PFP-50N	7.3 mm	1.5 mm
NS 35/ 7,5 PERF	7.5 mm	1.7 mm
NS 35/ 15 PERF	15 mm	9.2 mm

- End Plate dimension

End Plate model	(C) End Plate dimension
PFP-M	10 mm
CLIPFIX 35	9.5 mm

Installation Height

With a height of 100 mm, the CPU Unit is the highest component in an NX-series CPU Rack. When a cable is connected (such as a Unit communications cable), however, even greater height is required. Allow sufficient depth in the control panel containing the Controller.

The following figure shows the dimensions from the cables connected to the CPU Rack to the back of the Unit. The unit of dimension is millimeter.

The height from the mounting surface of the DIN Track varies depending on the DIN Track to be used. Refer to *Installation Dimensions* on page 4-29 for the height of individual DIN Track type.

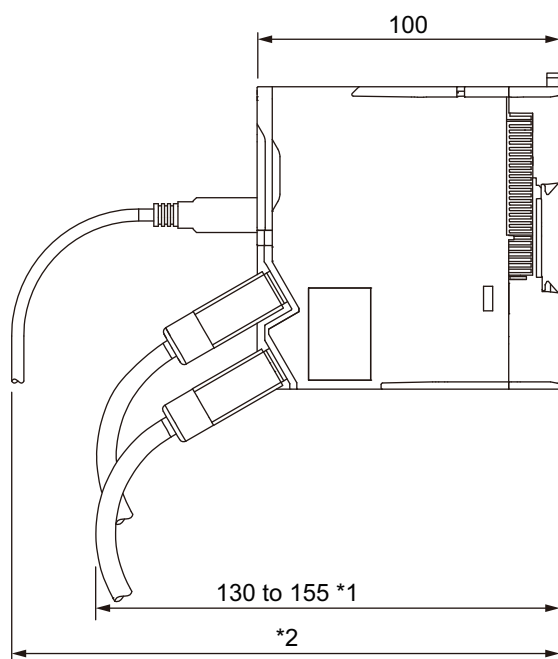

*1. This is the dimension from the back of the Unit to the communications cables.

130 mm: When an MPS588-C Connector is used.

155 mm: When an XS6G-T421-1 Connector is used.

*2. This dimension depends on the specifications of the commercially available USB cable. Check the specifications of the USB cable that is used.

4-4 Wiring

⚠ WARNING

- Do not input a voltage or current that exceeds the specified range into a Unit or slave. If a voltage or current that is outside the specified range is input, the Unit or slave may fail or a fire may occur.



⚠ CAUTION

- Tighten terminal block screws and cable screws to the torques specified in this manual or in the reference manuals. The loose screws may result in fire or malfunction.
- Do not touch devices while power is supplied or immediately after the power supply is turned OFF. You may be burnt.



Precautions for Safe Use

- Use crimp terminals for wiring.
- Do not connect bare stranded wires directly to terminals.



Additional Information

Do not allow wire clippings, shavings, or other foreign material to enter any Unit. Otherwise, Unit burning, failure, or malfunction may occur. Cover the Units or take other suitable countermeasures, especially during wiring work.

4-4-1 Power Supply Wiring

AC Power Supply Units

● NX-PA9001 Power Supply Unit

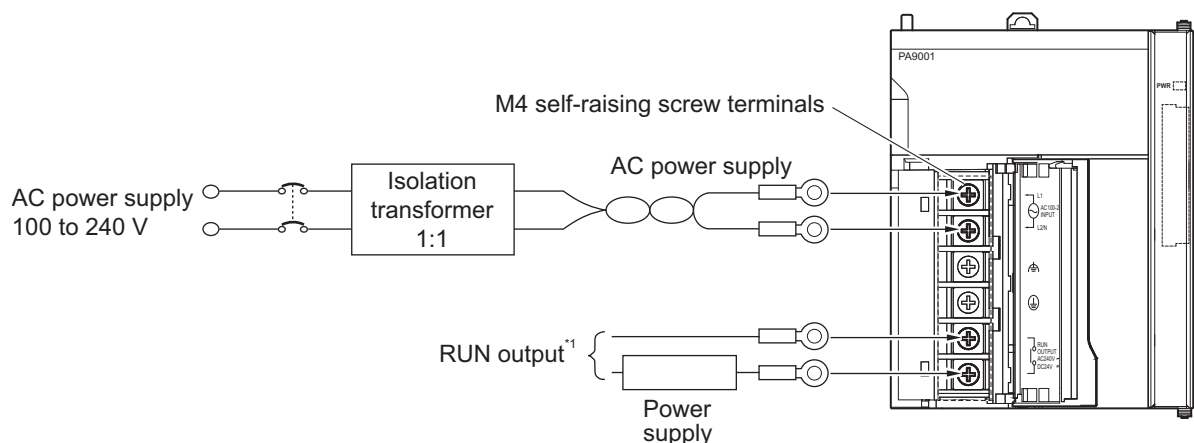

*1. The RUN output is ON when the CPU Unit is in RUN mode and OFF when the CPU Unit is in PROGRAM mode or a Controller error in the major fault level occurs.

● AC Power Supply

- Supply 100 to 240 VAC.
- Use the Power Supply Unit of the voltage and frequency shown in the table below.

Model	Power supply voltage
NX-PA9001	100 to 240 VAC 50/60 Hz (85 to 264 VAC, 47 to 63 Hz)

- If one power supply phase of the equipment is grounded, connect the grounded phase side to the L2/N terminal.

● Isolation Transformer

The Controller's internal noise isolation circuits are sufficient to control typical noise in power supply lines. Noise between the Controller and ground can be significantly reduced by connecting a 1- to-1 isolation transformer. Do not ground the secondary coil of the transformer.

● Power Supply Capacity

The power consumption will be 150 VA maximum per Rack for the NX-PA9001. When you select the power supply, consider that inrush current will flow when the power is turned ON.

Refer to *3-3-1 Models and Specifications* on page 3-11 for inrush current specifications.

● RUN Output

This output is ON when the CPU Unit is operating; it is OFF when the CPU Unit is in PROGRAM mode or a Controller error in the major fault level occurs.

The RUN output can be used to control external systems, such as in an emergency stop circuit that turns OFF the power supply to external systems when the CPU Unit is not operating. (Refer to *4-2 Fail-safe Circuits* on page 4-6 for more information.)

Refer to *NX7-series Power Supply Units* on page 3-11 for switching capacity specifications for contacts.

● Terminal Screws and Crimp Terminals

The terminals on the Power Supply Unit are M4, self-raising terminals with screws.

Use crimp terminals (M4) having the dimensions shown below. Tighten the terminal block screws to the torque of 1.2 N·m.

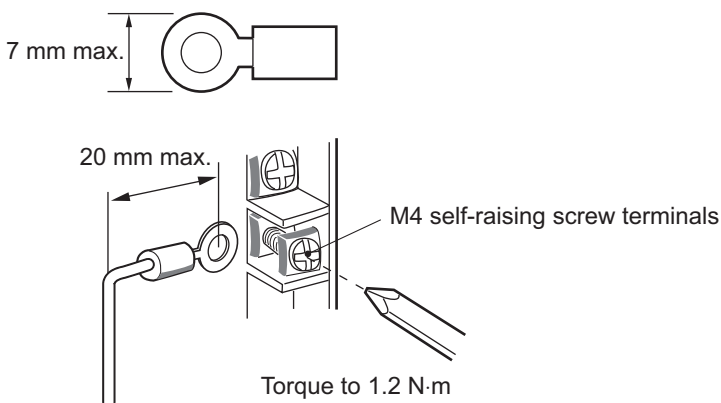

DC Power Supplies

● Precautions When Using A Non-isolated Power Supply Unit NX-PD7001



CAUTION

When you connect a computer or other peripheral device to a Controller that has a non-isolated DC Power Supply Unit NX-PD7001, either ground the 0-V side of the external power supply or do not ground it at all.

If the peripheral devices are grounded incorrectly, the external power supply may be short-circuited. Never ground the 24-V side of the power supply, as shown in the following figure.

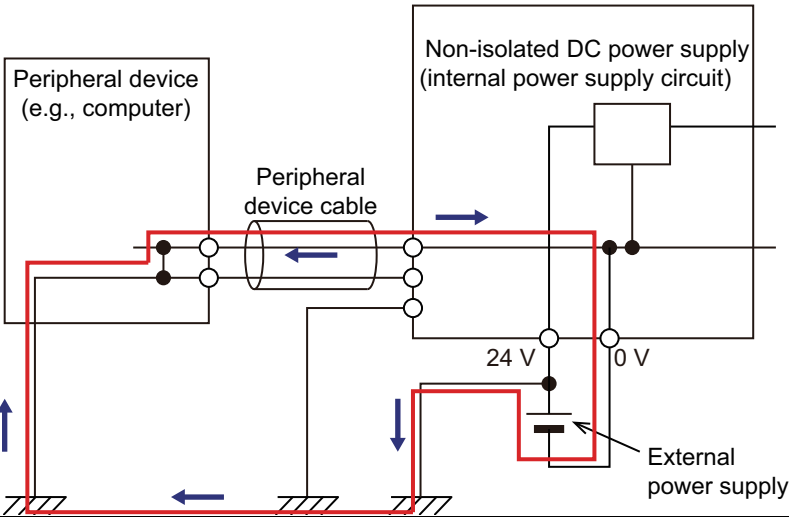

● Wiring for NX-PD7001

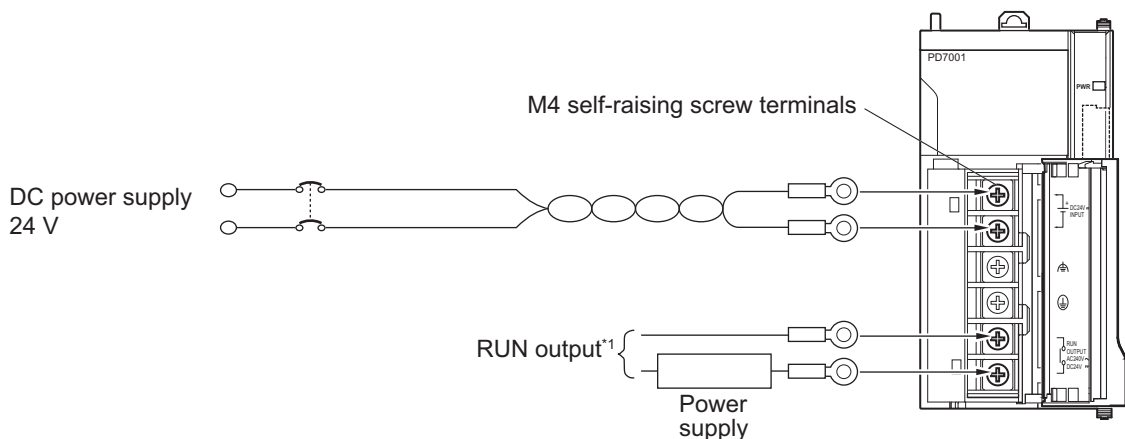

*1. The RUN output is ON when the CPU Unit is in RUN mode and OFF when the CPU Unit is in PROGRAM mode or a Controller error in the major fault level occurs.

● DC Power Supply

- Supply 24 VDC.
- Use the Power Supply Unit of the voltage shown in the table below.

Model	Power supply voltage
NX-PD7001	24 VDC (20.4 to 28.8 VDC)

● Power Supply Capacity

The power consumption will be 85 W maximum per Rack for the NX-PD7001. When you select the power supply, consider that inrush current will flow when the power is turned ON.

Refer to *3-3-1 Models and Specifications* on page 3-11 for inrush current specifications.

We recommend that you use the OMRON S8JX-series or S8VS-series Power Supplies, all of which have the capacity of 180 W or greater.

● RUN Output

This output is ON when the CPU Unit is operating; it is OFF when the CPU Unit is in PROGRAM mode or a Controller error in the major fault level occurs.

The RUN output can be used to control external systems, such as in an emergency stop circuit that turns OFF the power supply to external systems when the CPU Unit is not operating. (Refer to *4-2 Fail-safe Circuits* on page 4-6.)

Refer to *NX7-series Power Supply Units* on page 3-11 for switching capacity specifications for contacts.

● Terminal Screws and Crimp Terminals

The terminals on the Power Supply Unit are M4, self-raising terminals with screws.

Use crimp terminals (M4) having the dimensions shown below. Tighten the terminal block screws to the torque of 1.2 N·m.

Crimp Terminals for DC Power Supplies

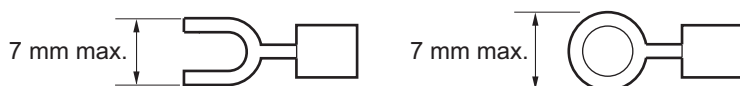

4-4-2 Grounding

This section describes how to ground the CPU Rack.

Units with Ground Terminals and Type of Ground Terminals

● Power Supply Units

Power Supply Units NX-PA9001 and NX-PD7001

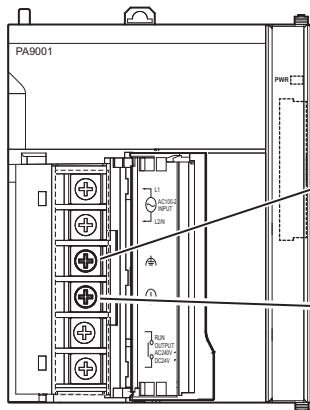

LG (Noise-filter neutral terminal)
Ground this terminal to less than 100 Ω
to improve noise resistance and prevent
electric shock.

GR (Ground terminal)
Ground this terminal to less than 100 Ω
to prevent electric shock.

Terminal name	Grounding type	Symbol	Function
LG	Functional Grounding		Functional grounding is done to protect device and system functions, including prevention of noise from external sources, or prevention of noise from devices or equipment that could have harmful effects on other devices or equipment.
GR	Protective Grounding		Protective grounding is done to ensure safety. It is intended to prevent electrical shock by grounding the electrical potential that is generated by factors such as leakage, induction, or failure.

• Terminal Screws and Crimp Terminals

The terminals on the Power Supply Unit are M4, self-raising terminals with screws.

Use crimp terminals (M4) having the dimensions shown below. Tighten the terminal block screws to the torque of 1.2 N·m.



DIN Track Contact Plates

A Unit that has a ground terminal also has a DIN Track contact plate on the back of the Unit. The DIN Track contact plate is connected internally to the ground terminal on the Unit. This means that the ground terminal will be electrically connected to the DIN Track.

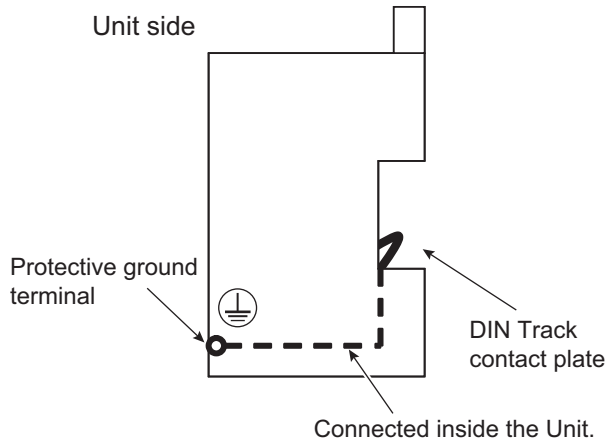

Additional Information

The CPU Unit has no ground terminals, thus no DIN Track Contact Plates.

Therefore, the grounding part of the CPU Unit will be grounded through the Power Supply Unit.

Grounding the CPU Rack

This section describes how to ground the ground terminals on the CPU Rack.

The protective ground terminals on the Power Supply Units, the functional ground terminals that are provided on some Units, and the DIN Track are grounded.

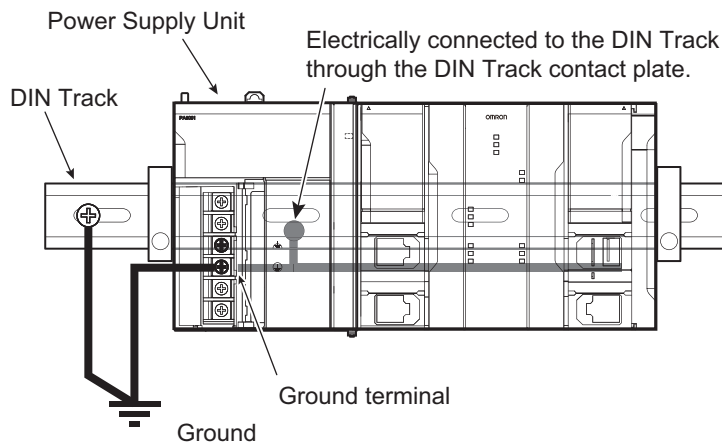

- To help prevent electrical shock, ground the ground terminal (GR: \ominus) of the Power Supply Unit with a ground resistance of less than 100 Ω using a 14-gauge wire (minimum cross-sectional area of 2 mm²).
- The line ground terminal (LG: \oplus) of the Power Supply Unit is a noise filter neutral terminal. If noise is a significant source of errors or electrical shocks are a problem, connect the line ground terminal to the ground terminal and ground both with a ground resistance of less than 100 Ω .
- If the LG and GR terminals of the Power Supply Unit are connected, ground to a resistance of 100 Ω or less to prevent electric shock.
- The ground wire should not be more than 20 m long.

- When wiring an AC Power Supply Unit, if one power supply phase of the equipment is grounded, always connect the grounded phase to the L2/N terminal.

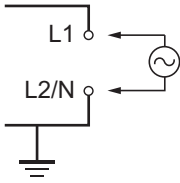

When using the DC Power Supply Unit, you can omit grounding the ground terminals.

- If the DIN Track is made of steel and its surface is not insulated.

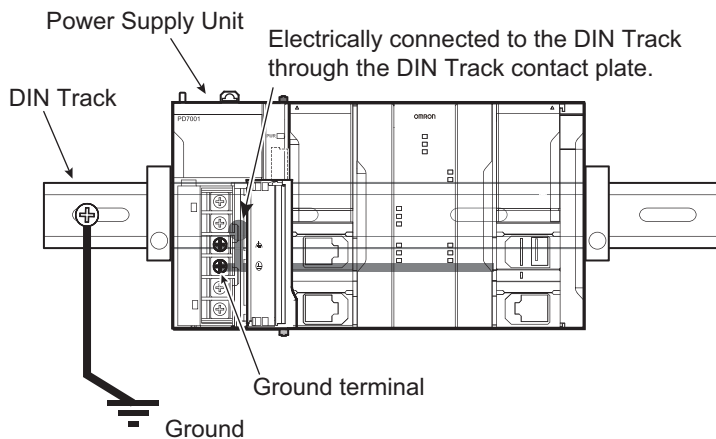

If the surface of the DIN Track is treated to produce an insulating material (e.g., anodized aluminum), the DIN Track contact plate will not be electrically connected to the DIN Track even if they are in physical contact.

Isolating the CPU Rack from the Control Panel

If the ground wire for a Unit with a ground terminal is shared with power equipment, noise will adversely affect the Units.

You can use OMRON NX-AUX01 DIN Track Insulation Spacers with PFP-50N or PFP-100N DIN Tracks to isolate the CPU Rack from the control panel.

● Installing DIN Track Insulation Spacers and DIN Track

Secure the DIN Track Insulation Spacers to the control panel with screws, and then secure the DIN Track to the DIN Track Insulation Spacers. The recommended tightening torque for M4 screws is 1.2 N·m.

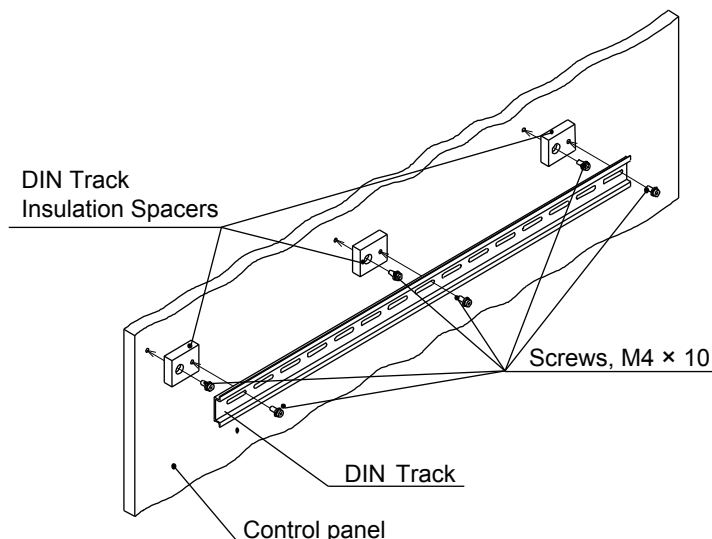

- DIN Track Insulation Spacers
NX-AUX01 (OMRON Corporation)

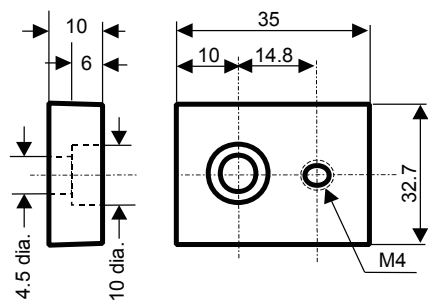

Precautions for Correct Use

If you use DIN Track Insulation Spacers to install a CPU Rack, the height will be increased by approximately 10 mm. Make sure that the CPU Rack and connecting cables do not come into contact with other devices.

4-4-3 Wiring the Built-in EtherCAT Port

For information on wiring the built-in EtherCAT port, refer to the *NJ/NX-series CPU Unit Built-in EtherCAT Port User's Manual* (Cat. No. W505).

4-4-4 Wiring the Built-in EtherNet/IP Port

For information on wiring the built-in EtherNet/IP port, refer to the *NJ/NX-series CPU Unit Built-in EtherNet/IP Port User's Manual* (Cat. No. W506).

4-5 Control Panel Installation

To ensure system reliability and safety, the system must be designed and configured according to the installation environment (temperature, humidity, vibration, shock, corrosive gases, overcurrent, noise, etc.).

4-5-1 Temperature

Panels have been reduced in size due to space-saving and miniaturization in devices and systems, and the temperature inside the panel may be at least 10 to 15°C higher than outside the panel. Implement the following measures against overheating at the installation site and in the panel, and allow a sufficient margin for the temperature.

High Temperatures

Use the following cooling methods as required, taking into account the ambient temperature and the amount of heating inside the panel.

● Natural Cooling

- Natural cooling relies on natural ventilation through slits in the panel, rather than using cooling devices such as fans or coolers. When using this method, observe the following points.
- Do not install the Controller at the top of the panel, where hot air tends to stagnate.
- To provide ventilation space above and below the Controller, leave sufficient distance from other devices, wiring ducts, etc.
- Do not mount the Units in the wrong direction (e.g., vertically or upside down). Doing so may cause abnormal heating in the Controller.
- Do not install the Controller directly above any heat-generating equipment, such as heaters, transformers, and devices with high resistance.
- Do not install the Controller in a location exposed to direct sunlight.

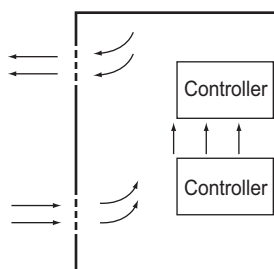

Natural Cooling

● **Forced Ventilation (by Fan at Top of Panel)**

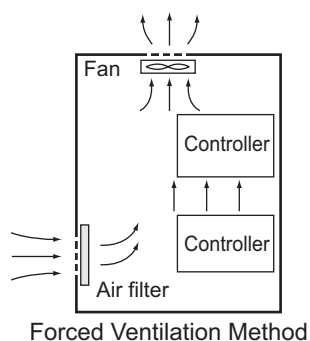

Forced Ventilation Method

● **Forced Air Circulation (by Fan in Closed Panel)**

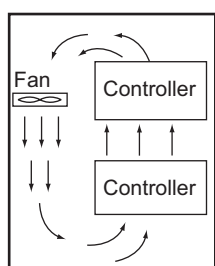

Forced Air Circulation

● **Room Cooling (Cooling the Entire Room Where the Control Panel Is Located)**

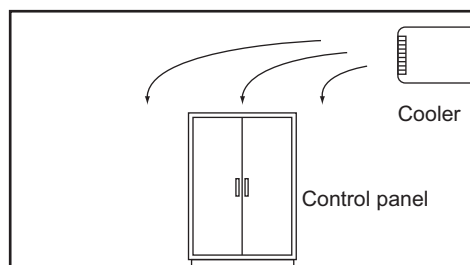

Room Cooling

Low Temperatures

The Controller may not start normally if the temperature is below 0°C when the power is turned ON.

Maintain an air temperature of at least approximately 5°C inside the panel, by implementing measures such as installing a low-capacity space heater in the panel.

Alternatively, leave the Controller power ON to keep the Controller warm.

4-5-2 Humidity

Rapid temperature changes can cause condensation to occur, resulting in malfunctioning due to short-circuiting.

When there is a possibility of this occurring, take measures against condensation, such as leaving the Controller power ON at night or installing a heater in the control panel to keep it warmer.

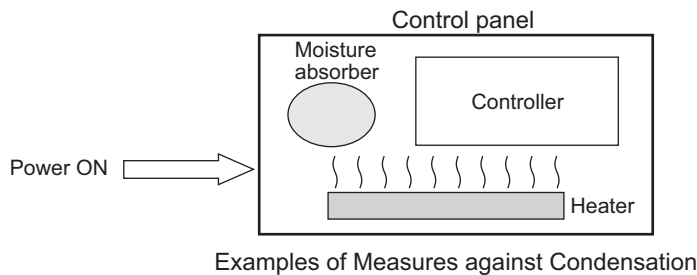

4-5-3 Vibration and Shock

The Controller is tested for conformity with the sine wave vibration test method (IEC 60068-2-6) and the shock test method (IEC 60068-2-27) of the Environmental Testing for Electrotechnical Products. It is designed so that malfunctioning will not occur within the specifications for vibration and shock. If, however, the Controller is to be used in a location in which it will be directly subjected to regular vibration or shock, then implement the following countermeasures:

- Separate the control panel from the source of the vibration or shock.
Or secure the Controller and the panel with rubber padding to prevent vibration.
- Make the building or the floor vibration-resistant.
- To prevent shock when other devices in the panel such as electromagnetic contactors operate, secure either the source of the shock or the Controller with rubber padding.

4-5-4 Atmosphere

Using the Controller in any of the following locations can cause defective contact with connectors and corrosion of components. Implement countermeasures such as purging the air as required.

- In locations exposed to dust, dirt, salt, metal powder, soot, or organic solvents, use a panel with an airtight structure. Be careful of temperature increases inside the panel.
- In locations exposed to corrosive gas, purge the air inside the panel to clear the gas and then pressurize the inside of the panel to prevent gas from entering from outside.
- In locations where flammable gas is present, either use an explosion-protected construction or do not use the Controller.

4-5-5 Electrical Environment

When installing or wiring devices, make sure that there will be no danger to people and that noise will not interfere with electrical signals.

Controller Installation Location

Install the Controller as far away as possible from high-voltage (600 V or higher) and power devices to ensure safe operation and maintenance.

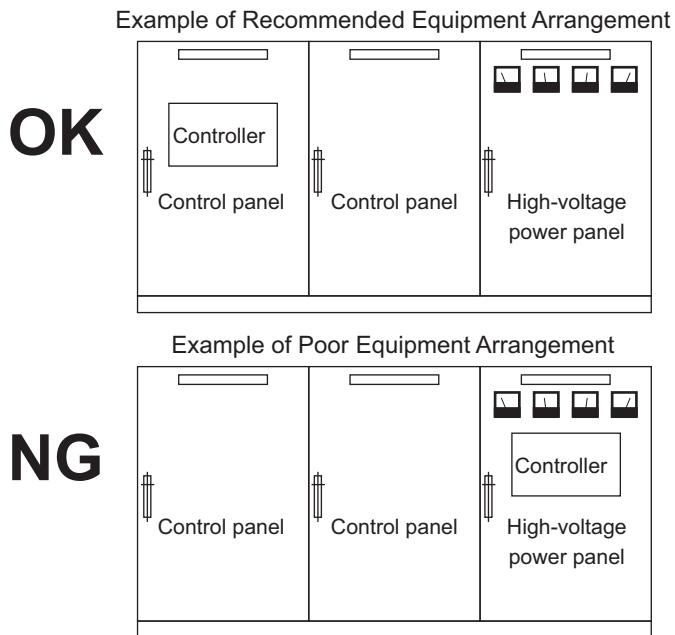

Examples of Equipment Arrangement in Panel with High-voltage Devices

Arrangement of Controller and Units

The coils and contacts in electromagnetic contacts and relays in an external circuit are sources of noise. Do not install them close to the Controller. Locate them at least 100 mm away from the Controller.

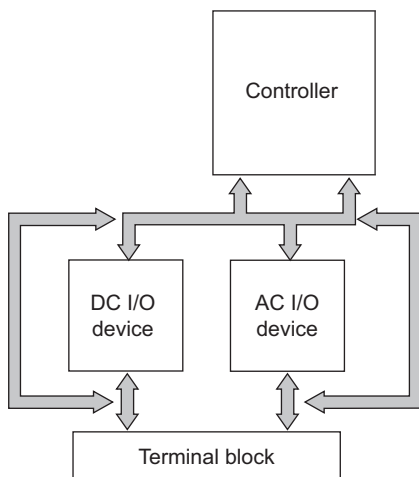

Example of Arrangement in Panel

Wire Layout for the Power Supply System

Observe the following points when wiring the power supply system.

- Separate the Controller power supply from the I/O device power supply and install a noise filter near the Controller power supply feed section.
- Use an isolating transformer to significantly reduce noise between the Controller and the ground. Install the isolating transformer between the Controller power supply and the noise filter, and do not ground the secondary coil of the transformer.
- Keep the wiring between the transformer and the Controller as short as possible, twist the wires well, and keep the wiring separate from high-voltage and power lines.

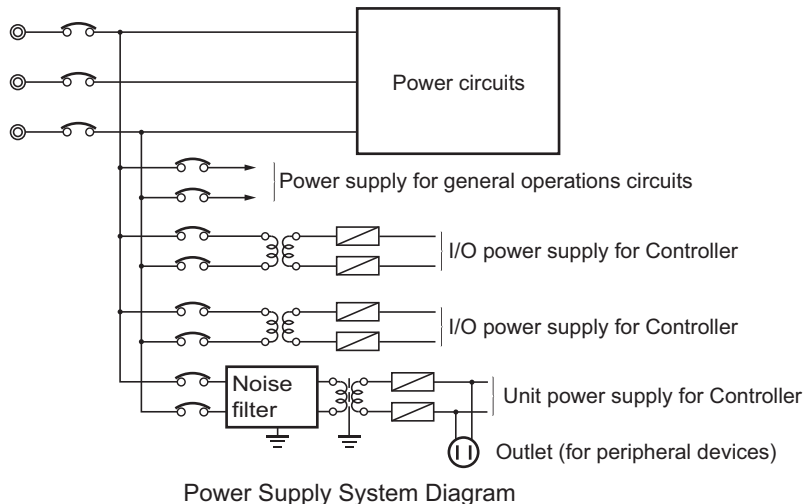

Wiring External I/O Signal Lines

Observe the following points when wiring external I/O signal lines.

- To absorb reverse electromotive force when an inductive load is connected to an output signal, connect a surge suppressor near the inductive load in an AC circuit, or connect a diode near the inductive load in a DC circuit.

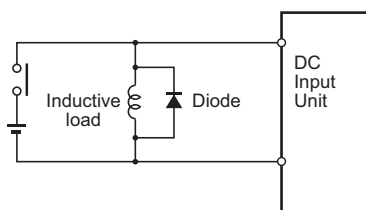

Connect a diode in a DC circuit.

Input Signal Noise Countermeasures

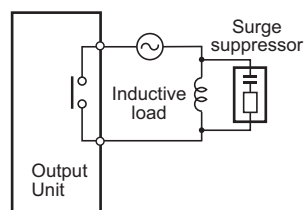

Connect a surge suppressor in an AC circuit.

Output Signal Noise Countermeasures

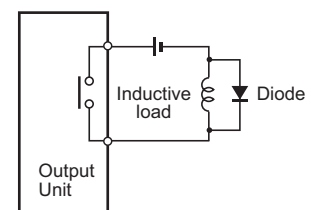

Connect a diode in a DC circuit.

- Never bundle output signal lines with high-voltage or power lines, and do not route them in close proximity or parallel to such lines.
If output signal lines must be routed in close proximity to such lines, place them in separate ducts or conduits. Be sure to ground the ducts or conduits.

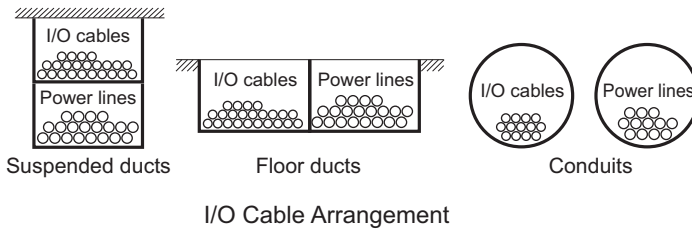

- If the signal lines and power lines cannot be routed in separate ducts, use shielded cable. Connect the shield to the ground terminal at the Controller, and leave it unconnected at the input device.
- Wire the lines so that common impedance does not occur.
Such wiring will increase the number of wires, so use common return circuits.
Use thick wires with sufficient allowance for the return circuits, and bundle them with lines of the same signal level.
- For long I/O lines, wire the input and output signal lines separately.
- Use twisted-pair wires for pilot lamps (and particularly lamps with filaments).
- Use countermeasures, such as CR surge absorbers and diodes, for input device and output load device noise sources, as required.

External Wiring

Wiring, and noise countermeasures in particular, are based on experience, and it is necessary to closely manage wiring based on experience and information in the manuals.

● Wiring Routes

Each of the following combinations includes different signal types, properties, or levels. They will cause the signal-to-noise ratio to drop due to factors such as electrical induction. As a general rule when wiring, either use separate cables or separate wiring routes for these items. Future maintenance operations and changes to the system will also be made easier by carefully organizing the wiring from the start.

- Power lines and signal lines
- Input signals and output signals
- Analog signals and digital signals
- High-level signals and low-level signals
- Communications lines and power lines
- DC signals and AC signals
- High-frequency devices (such as Inverters) and signal lines (communications)

● Wiring

Observe the following points when wiring power supply and signal cables.

- When routing signal cables with differing characteristics through the same duct, always keep them separated.
- As much as possible, avoid routing multiple power supply lines through the same duct. If it cannot be avoided, then construct a partition between them in the duct and ground the partition.

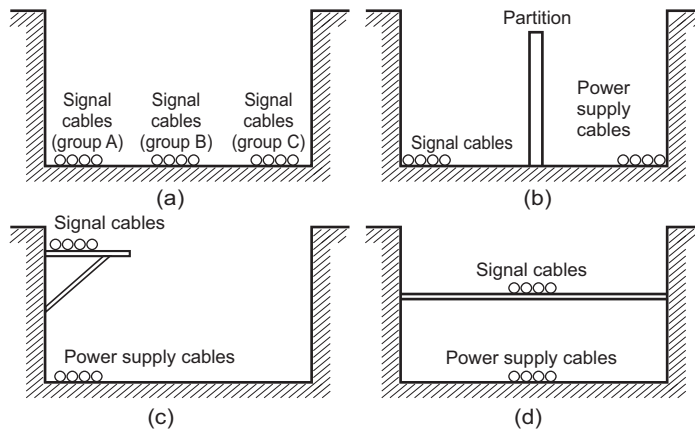

Partitioning Methods for Signal and Power Supply Cables

- To avoid overheating the conduits when using conduits for wiring, do not place wires for a single circuit in separate conduits.

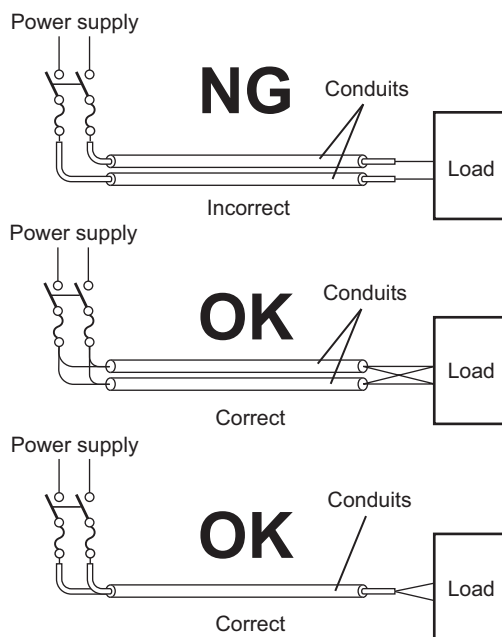

Parallel Wiring (Single Phase)

- Power cables and signal cables adversely affect each other. Do not wire them in parallel.
- Noise induction may occur if the Controller is installed in a panel that includes high-voltage devices. Wire and install them as far apart as possible. (Refer to *Controller Installation Location* on page 4-42.)

- Either install the Controller a minimum of 200 mm away from high-voltage lines or power lines, or place the high-voltage lines or power lines in metal tubing and completely ground the metal tubing to 100 Ω or less.

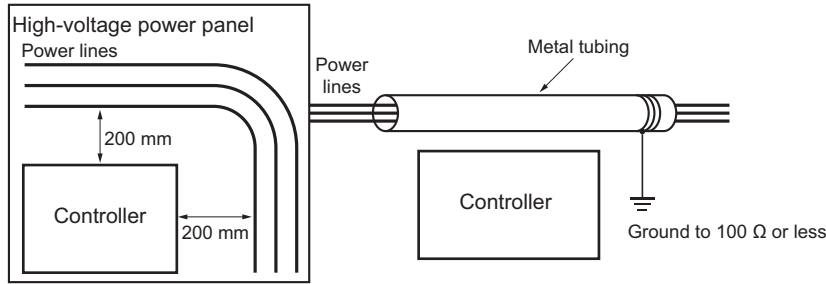

Example: Separating Controller from Power Lines

● **Other Precautions**

- Basic I/O Units have both plus and minus commons, so pay attention to the polarity when wiring.

4-5-6 Grounding

This section describes the earthing methods and precautions.

Considerations for Earthing Methods

Local potential fluctuations due to lightning or noise occurred by power devices will cause potential fluctuations between ground terminals of devices. This potential fluctuation may result in device malfunction or damage. To prevent this, it is necessary to suppress the occurrence of a difference in electrical potential between ground terminals of devices. You need to consider the earthing methods to achieve this objective.

The recommended earthing methods for each usage condition are given in the following table.

Specification of communications cables for EtherCAT and EtherNet/IP	Earthing methods			
	Equipotential bonding system	Star earthing		Daisy chain
		Connecting devices and noise sources to separate earth electrodes	Connecting devices and noise sources to a common earth electrode	
The cable shield connected to the connector hood at both ends of the communications cable ^{*1}	Recommended	Recommended	Not recommended	Not recommended
The cable shield connected to the connector hood at only one end of the communications cable ^{*2}	Recommended	Recommended	Not recommended	Not recommended
Neither EtherCAT nor EtherNet/IP used	Recommended	Recommended	Not recommended	Not recommended

*1. Use this cable when using EtherCAT or when using EtherNet/IP with 1000BASE-T.

*2. You can use either of cables when not using EtherCAT or when using EtherNet/IP with 100BASE-TX or 10BASE-T.



Additional Information

- In a country or region where the earthing method is regulated, you must comply with the regulations. Refer to the applicable local and national ordinances of the place where you install the system, or other international laws and regulations.
- For details on wiring EtherCAT or EtherNet/IP, refer to the *NJ/NX-series CPU Unit Built-in EtherCAT Port User's Manual* (Cat. No. W505) or the *NJ/NX-series CPU Unit Built-in EtherNet/IP Port User's Manual* (Cat. No. W506).
- Ethernet switches are used with the EtherNet/IP. For information on the environmental resistance of the Ethernet switch to use, the grounding between Ethernet switches, or the specifications of cables, ask the Ethernet switch manufacturer.

Each of these earthing methods is given below.

● Equipotential Bonding System

Equipotential bonding is an earthing method in which steel frames and building structures, metal ducts and pipes, and metal structures in floors are connected together and make connections to the earth trunk line to achieve a uniform potential everywhere across the entire building. We recommend this earthing method.

The following figure shows an example of an equipotential bonding system.

Connect the main earthing terminal and building structures together with equipotential bonding conductors and embed the mesh ground line in each floor.

Connect the ground line of each control panel to the equipotential bonding system.

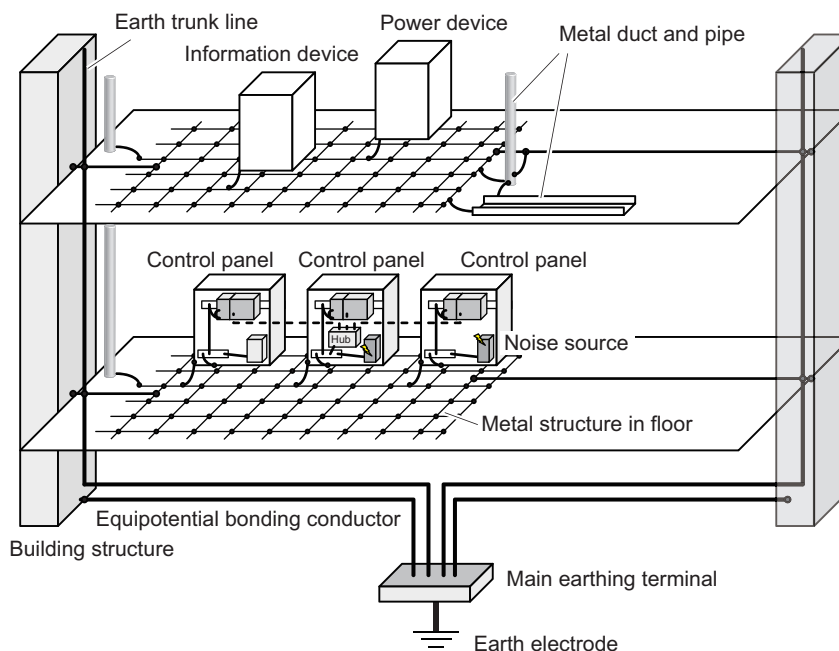

● Star Earthing

If the earthing method used for the building is not equipotential bonding or the earthing system is unknown, choose a) from among the earthing methods given below.

a) Connecting devices and noise sources to separate earth electrodes

This is an earthing method to separately ground an earth electrode of the device that is connected with a communications cable or other devices and an earth electrode of a high-power device that could be a noise source, such as a motor or inverter.

Each earth electrode must be ground to 100 Ω or less.

Connect the ground lines of the device that is connected with a communications cable and other devices as a bundle to a single earth electrode. Be sure that the earth electrode is separated by a minimum of 10 m from any other earth electrode of a device that could be a noise source.

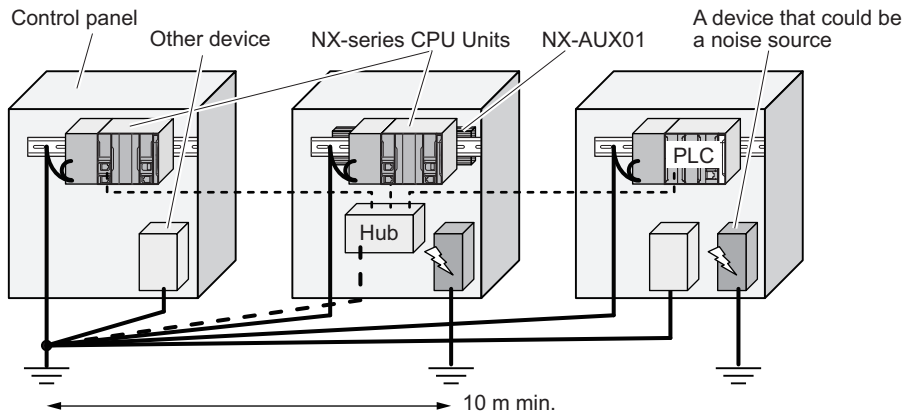

b) Connecting devices and noise sources to a common earth electrode

This is an earthing method to connect the device that is connected with a communications cable, other devices, and a device that could be a noise source, to a common earth electrode.

This earthing method is not recommended because the device that could be a noise source may interfere electromagnetically with other devices.

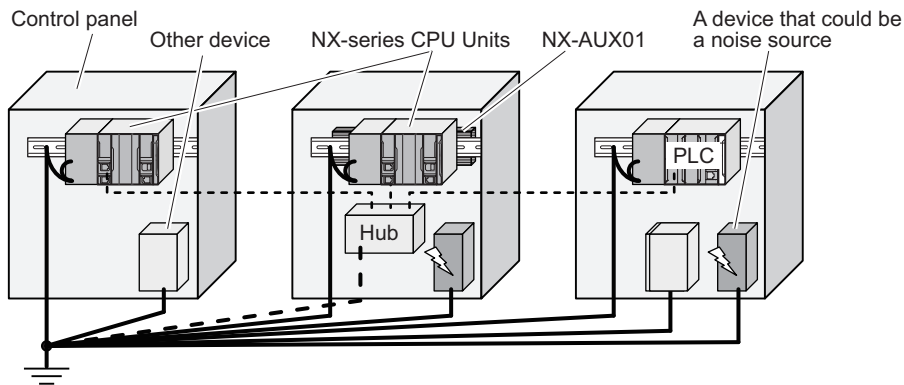

● **Daisy Chain**

This is an earthing method to connect the device that is connected with a communications cable, other devices, and a device that could be a noise source using a daisy-chain topology to a common earth electrode.

This earthing method is not recommended because the device that could be a noise source may interfere electromagnetically with other devices.

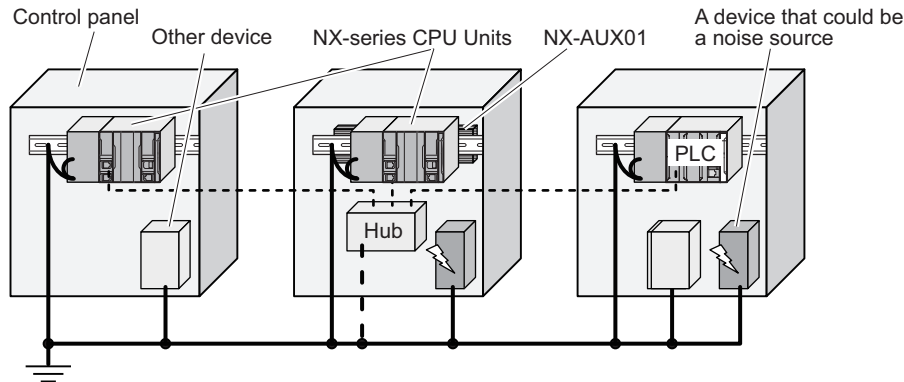

Precautions for Grounding

● General Precautions

- To prevent electrical shock, do not connect devices to ground poles (or steel frames) with non-equalized potential to which multiple devices are connected.
- Use a ground pole as close to the Controller as possible and keep the ground line as short as possible.
- If the same ground is used for both the signal lines and the enclosure, isolate the channel base (a grounded metal plate inside a control panel) with an insulating material.

Refer to *Isolating the CPU Rack from the Control Panel* on page 4-37 for how to isolate the NX-series Controllers.

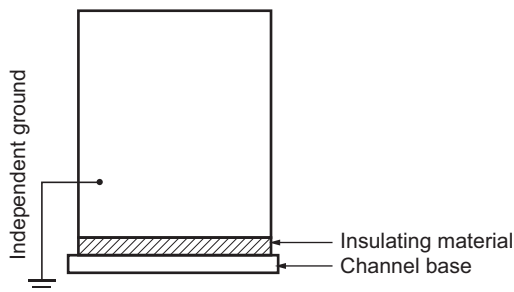

Example: Insulating and Grounding an Enclosure

- To prevent influence from leakage current from other electrical devices, electrically isolate the panel in which the Controller is housed from other devices.
- If high-frequency equipment is present, then ground not only the high-frequency equipment but also the panel itself in which the Controller is housed.
- As shown in the following diagram, when using shielded cable for I/O wiring, connect the shield near the Controller to the enclosure ground terminal.

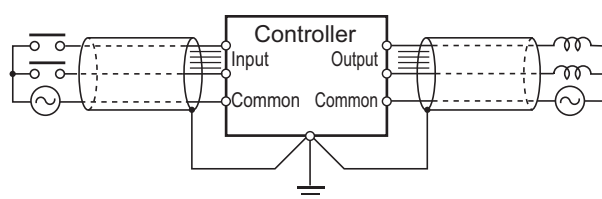

Follow the instructions in the Communications Unit manual for preparing shielded communications cable.



Shielded Cable Ground

● **Controller Ground Terminals**

The Controller has the following two ground terminals.

Terminal name	Grounding type	Symbol	Connection
LG	Functional Grounding		Ground this terminal when power supply noise causes malfunctioning.
GR	Protective Grounding		Always ground this terminal to prevent electrical shock.

When the functional ground terminal is correctly grounded, it is generally effective in suppressing power supply common noise. Occasionally, however, grounding this terminal will result in picking up more noise, so be careful when using it.

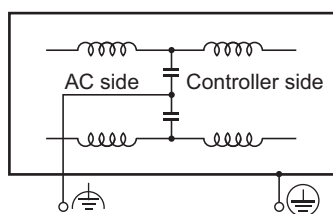

Controller Ground Terminals

- **When wiring to an AC Power Supply Unit, if one power supply phase of the equipment is grounded, always connect the grounded phase to the L2/N terminal.**

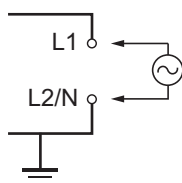

5

Troubleshooting

This section describes the confirmation methods and corrections for errors that occur in the NX-series Controller and describes hardware-related errors that can occur in the PLC Function Module.

5-1	Operation after an Error	5-2
5-1-1	Overview of NX-series Status	5-2
5-1-2	Fatal Errors in the CPU Unit	5-3
5-1-3	Non-fatal Errors in the CPU Unit	5-4
5-2	Troubleshooting	5-11
5-2-1	Checking to See If the CPU Unit Is Operating	5-11
5-2-2	Troubleshooting Flowchart for Non-fatal Errors	5-12
5-2-3	Error Table	5-13
5-2-4	Error Descriptions	5-23

5-1 Operation after an Error

This section describes the error status of the NX-series Controller and the operation that occurs after an error is detected. Refer to *5-2 Troubleshooting* for details on corrections for specific errors. Refer to the *NJ/NX-series Troubleshooting Manual (Cat. No. W503)* for all of the errors that may occur in an NX-series Controller.

5-1-1 Overview of NX-series Status

You can check the operating status of the CPU Unit with the PWR, RUN, and ERROR indicators on the front panels of the Power Supply Unit and CPU Unit.

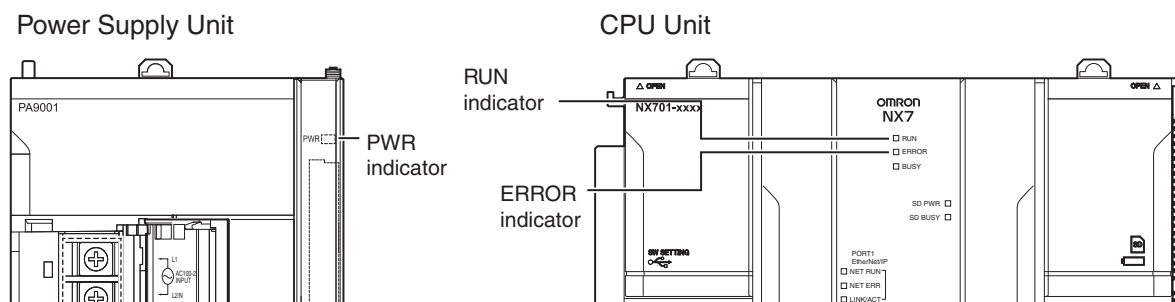

The following table shows the status of front-panel indicators, the status of user program execution, and the ability to connect communications to the Sysmac Studio or an HMI during startup, during normal operation, and when errors occur.

CPU Unit operating status		Power Supply Unit	CPU Unit		User program execution status	Communications with Sysmac Studio or an HMI
		PWR (green)	RUN (green)	ERROR (red)		
Startup		Lit	Flashing (2-s intervals followed by 0.5-s intervals)	Not lit	Stopped.	Not possible.
Normal operation	RUN mode	Lit	Lit	Not lit	Continues.	Possible.
	PROGRAM mode	Lit	Not lit	Not lit	Stopped.	
Fatal error in CPU Unit	Power Supply Error^{*1}	Not lit	Not lit	Not lit	Stopped.	Not possible.
	CPU Unit Reset^{*1}	Lit	Not lit	Not lit	Stopped.	
	CPU Unit Error^{*1}	Lit	Not lit or Flashing (2-s intervals or 0.5-s intervals)	Lit	Stopped.	
	System Initialization Error^{*1}	Lit	Flashing (2-s intervals) for 30 s or longer	Not lit	Stopped.	
Non-fatal error in CPU Unit	Major fault^{*2}	Lit	Not lit	Lit	Stopped.	Possible. (Communications can be connected from an HMI if EtherNet/IP is operating normally.)
	Partial fault^{*2}	Lit	Lit	Flashing (1-s intervals)	Continues. ^{*3}	
	Minor fault^{*2}	Lit	Lit	Flashing (1-s intervals)	Continues.	
	Observation^{*2}	Lit	Lit	Not lit	Continues.	

*1 Refer to 5-1-2 *Fatal Errors in the CPU Unit* for information on individual errors.

*2 Refer to 5-1-3 *Non-fatal error in CPU Unit* for information on individual errors.

*3 The function module where the error occurred stops.

5-1-2 Fatal Errors in the CPU Unit

Types of Fatal Errors

Some errors are fatal and prevent the CPU Unit from operating. This section describes the errors that cause the operation of the CPU Unit to stop. Communications with the Sysmac Studio or an HMI are not possible if there is a fatal error in the Controller.

● Power Supply Error

Power is not supplied, the voltage is outside of the allowed range, or the Power Supply Unit is faulty.

● CPU Unit Reset

The CPU Unit stopped operation because of a hardware error.

● CPU Unit Error

This error occurs in the CPU Unit. It indicates that there is a hardware failure or that the CPU is running out of control due to temporary data corruption.

● System Initialization Error

This error occurs in the CPU Unit. It indicates a hardware failure.

The RUN indicator will flash at 2-second intervals while the CPU Unit is starting, but if it flashes for 30 seconds or longer, then this error occurs.

Checking for Fatal Errors

You can identify fatal errors based on the status of the PWR indicator on the Power Supply Unit and the RUN and ERROR indicators on the CPU Unit, as well as by the ability to connect communications to the Sysmac Studio.

Indicator			Communications with Sysmac Studio	CPU Unit operating status
PWR (green)	RUN (green)	ERROR (red)		
Not lit	Not lit	Not lit	Not possible.*	Power Supply Error
Lit	Not lit	Not lit		CPU Unit Reset
Lit	Not lit or Flashing (2-s intervals or 0.5-s intervals)	Lit		CPU Unit Error
Lit	Flashing (2-s intervals) for 30 s or longer	Not lit		System Initialization Error

* An online connection to the Sysmac Studio is necessary to differentiate between CPU Unit Resets, CPU Unit Errors, and non-fatal errors in the CPU Unit. Power Supply Errors and System Initialization Errors can be differentiated with the indicators. There is no need to see if you can go online with the CPU Unit from the Sysmac Studio.

5-1-3 Non-fatal Errors in the CPU Unit

Event Levels

Non-fatal errors that occur are managed as Controller events in the NX-series Controller. Controller events are classified into levels according to the degree of the effect that the events have on control. When an event occurs, the Sysmac Studio or HMI will display the level. Refer to the *NJ/NX-series Troubleshooting Manual* (Cat. No. W503) for details on Controller events.

- **Major Fault Level**

These errors prevent control operations for the entire Controller. If a major fault level error is detected, user program execution is stopped immediately and the loads for all slaves (including remote I/O) are turned OFF. With EtherCAT slaves and some NX Units, you can set the slave settings or Unit settings to select whether outputs will go OFF or retain their previous status. You cannot reset major fault level errors from the user program, the Sysmac Studio or an HMI. To recover from a major fault level error, remove the cause of the error, and either cycle the power supply to the Controller or reset the Controller from the Sysmac Studio.
- **Partial Fault Level**

These errors prevent control operations in a certain function module in the Controller. The NX-series CPU Unit continues to execute the user program even after a partial fault level error occurs. You can include error processing in the user program to safely stop any devices in operation. After you remove the cause of the error, execute one of the following to return to normal status.

 - Reset the error from the user program, the Sysmac Studio, or an HMI.
 - Cycle the power supply.
 - Reset the Controller from the Sysmac Studio.
- **Minor Fault Level**

These errors prevent part of the control operations in a certain function module in the Controller. The troubleshooting for minor fault level errors is the same as the processing for partial fault level errors.
- **Observations**

These errors do not affect the control operations of the Controller. Observations serve as warnings to the user so that the error does not develop into an error at a higher level.
- **Information**

Events that are classified as information do not indicate errors.

You can change the event level for some events. Refer to *NJ/NX-series CPU Unit Software User's Manual* (Cat. No. W501) for information on changing event levels. Refer to *5-2 Troubleshooting* in this manual to see the events for which you can change the event level.

● Operation for Each Level

The operation that is performed when an error occurs depends on the error level of the Controller event.

Item	Event level					
	Controller errors				Controller information	
	Major fault level	Partial fault level	Minor fault level	Observation	Information	
Definition	These errors are serious errors that prevent control operations for the entire Controller.	These errors prevent all of the control in a function module other than PLC Function Module.	Errors that prevent a portion of control in one of the function modules.	Errors that do not affect control.	Information level events are not errors, but information provided to the user in the event log.	
Event examples (Only a few examples are provided here. Refer to the <i>NJ/NX-series Troubleshooting Manual (Cat. No. W503)</i> for a complete list of errors.)	<ul style="list-style-type: none"> Non-volatile Memory Data Corrupted (PLC Function) 	<ul style="list-style-type: none"> Motion Control Period Exceeded (Motion Control Function Module) Communications Controller Error (EtherCAT Master Function Module) 	<ul style="list-style-type: none"> Positive Limit Input Detected (Motion Control Function Module) Low Battery Voltage (PLC Function Module) 	<ul style="list-style-type: none"> Packet Discarded Due to Full Receive Buffer (EtherNet/IP Function Module) 	<ul style="list-style-type: none"> Power Turned ON Power Interrupted Memory All Cleared 	
Front-panel indicators*1	PWR (green)	Lit.	Lit.	Lit.	Lit.	Lit.
	RUN (green)	Not lit.	Lit.	Lit.	Lit.	Lit.
	ERROR (red)	Lit.	Flashes at 1-s intervals.	Flashes at 1-s intervals.	Not lit.	Not lit.

Item		Event level				
		Controller errors				Controller information
		Major fault level	Partial fault level	Minor fault level	Observation	Information
Operation of NX-series CPU Unit	RUN output on Power Supply Unit	OFF	ON	ON	ON	ON
	User program execution status	Stops.	Continues.*2	Continues.	Continues.	Continues.
	Outputs turned OFF	Yes	No	No	No	No
	Error reset	Not possible.	Depends on the nature of the error.	Depends on the nature of the error.	---	---
	Event logs	Recorded. (Some errors are not recorded.)	Recorded.	Recorded.	Recorded.	Recorded.
Outputs from EtherCAT slaves and Basic Output Units		Refer to the <i>I/O Operation for Major Fault Level Controller Errors</i> on page 5-7.	<ul style="list-style-type: none"> Errors in EtherCAT Master Function Module: Depends on settings in the slave. Errors in other function modules: Depends on user program. 	Depends on the user program.	Depends on the user program.	Depends on the user program.
Sysmac Studio display (while online)		Error messages are automatically displayed. You can display detailed information in the Troubleshooting Dialog Box.			These items are not displayed in the error display in the Controller Status Pane.	

*1 If multiple Controller errors have occurred, the indicators show the error with the highest error level.

*2 Operation stops in the function module (Motion Control Function Module, EtherCAT Master Function Module, or Ether-Net/IP Function Module) in which the error occurred.

● Operation in the Function Module Where an Error Event Occurred

Function module	Event level			
	Major fault level	Partial fault level	Minor fault level	Observation
PLC Function Module	User program execution stops.	---	Operation continues.	
Motion Control Function Module	All axes stop. (The stop method depends on the error.)	All axes stop. (The stop method depends on the error.)	<ul style="list-style-type: none"> The affected axis/axes group stops. (The stop method depends on the settings.) The motion control instructions that are related to axis operation are not executed. 	<ul style="list-style-type: none"> Axis operation continues. The motion control instructions that are not related to axis operation are not executed.
EtherCAT Master Function Module	I/O refreshing for EtherCAT communications stops. (The slaves operate according to the settings in the slaves.)	EtherCAT communications stop. (The slaves operate according to the settings in the slaves.)	I/O refreshing for EtherCAT communications stops or continues according to the fail-soft operation settings in the master. (If I/O refreshing stops, the slaves operate according to the settings in the slaves.)	I/O refreshing for EtherCAT communications continues.
EtherNet/IP Function Module	Part of the EtherNet/IP communications stop. (Online connection to the Sysmac Studio and communications connection with an HMI are possible. (Output (produce) tags in the tag data links operate according to the tag set settings.)	EtherNet/IP communications stop. (A software connection from the Sysmac Studio or an HMI is not possible.)	Part of EtherNet/IP communications stop. (A software connection from the Sysmac Studio or an HMI is possible if the communications connection is not the cause of the error.)	EtherNet/IP communications continue.

● I/O Operation for Major Fault Level Controller Errors

The following table gives the operation of the CPU Unit and the I/O devices.

Unit	CPU Unit operation	Unit or slave operation
EtherCAT Slave Terminal	The EtherCAT Slave Terminal moves to Safe-Operational state.	Depends on the NX Unit settings.
EtherCAT slave *1	The slave is placed in the Safe-Operational state.	Depends on the slave settings. *2
Servo Drive or NX Unit assigned to an axis	Updating the command values is stopped.	All axes stop immediately.
Devices connected with EtherNet/IP	<ul style="list-style-type: none"> For the originators of tag data links, the variables and I/O memory addresses for input (consume) tags are not refreshed. For the targets of tag data links, operation depends on the settings of the tags sets for the output (produce) tags. *3 	Depends on the specifications of the connected devices.

*1 Excluding Servo Drives assigned to an axis.

*2 Settings and setting methods depend on the slave. Refer to the manual for the slave. For a Servo Drive, operation depends on the setting of object 605E hex (Fault Reaction Option Code).

*3 You can set whether to clear output or maintain the data from before the error occurred. Refer to the *NJ/NX-series CPU Unit Built-in EtherNet/IP Port User's Manual* (Cat. No. W506) for details.

Checking for Non-fatal Errors

Use the following methods to check for non-fatal errors.

Checking method	What you can check
Checking the indicators	You can use the indicators to confirm the Controller error level, the error status of the EtherCAT Master Function Module, and the error status of the EtherNet/IP Function Module.
Checking with the troubleshooting function of Sysmac Studio	You can check for current Controller errors, a log of past Controller errors, error sources, error causes, and corrections.
Checking with the Troubleshooter of an HMI*1	You can check for current Controller errors, a log of past Controller errors, error sources, error causes, and corrections.
Checking with instructions that read function module error status	You can check the highest-level status and highest-level event code in the current Controller errors.
Checking with system-defined variables	You can check the current Controller error status for each function module.

*1 To perform troubleshooting from an HMI, connect the HMI to the built-in EtherNet/IP port on the CPU Unit. Refer to the appendices of the *NJ/NX-series Troubleshooting Manual* (Cat. No. W503) for the applicable range of the HMI Troubleshooter.

This section describes the above checking methods.

Checking the Indicators

● Checking the Level of a Controller Error

You can use the PWR indicator on the Power Supply Unit and the RUN and ERROR indicators on the CPU Unit to determine the event level for an error. The following table shows the relationship between the Controller's indicators and the event level.

Indicator			Event level
PWR (green)	RUN (green)	ERROR (red)	
Lit	Not lit	Lit	Major fault level
Lit	Lit	Flashing (1-s intervals)	Partial fault level
			Minor fault level
Lit	Lit	Not lit	Observation

● Checking the Status of EtherCAT and EtherNet/IP Ports

For the EtherCAT and EtherNet/IP ports, use the EtherCAT and EtherNet/IP NET ERR indicators to determine whether an error that affects process data communications has occurred and whether a minor fault level error or higher-level error has occurred. The indicator lets you check the status given in the following table.

Indicator	Indicated status
EtherCAT NET ERR	EtherCAT Port Status <ul style="list-style-type: none"> • Lit: An error for which normal status cannot be recovered through user actions (i.e., errors for which you must replace the CPU Unit or contact your OMRON representative) has occurred. • Flashing: An error for which normal status can be recovered through user actions has occurred. • Not lit: An error that affects process data communications has not occurred.
EtherNet/IP NET ERR	EtherNet/IP Port Status <ul style="list-style-type: none"> • Lit: An error for which normal status cannot be recovered through user actions (i.e., errors for which you must replace the CPU Unit or contact your OMRON representative) has occurred. • Flashing: An error for which normal status can be recovered through user actions has occurred. • Not lit: There is no minor fault level or higher-level error.

Checking with the Troubleshooting Function of Sysmac Studio

When an error occurs, you can connect the Sysmac Studio online to the Controller to check current Controller errors and the log of past Controller errors.

● Current Errors

Open the Sysmac Studio's Controller Error Tab Page to check the current error's level, source, source details, event name, event code, details, attached information 1 to 4, cause, and correction. Errors are not displayed for observations.

● Log of Past Errors

Open the Sysmac Studio's Controller Log Tab Page to check the time of occurrence, level, source, source details, event name, event code, details, attached information 1 to 4, and corrections for past errors.

Refer to the *Sysmac Studio Version 1 Operation Manual* (Cat. No. W504) for details on troubleshooting with the Sysmac Studio.

Checking with the Troubleshooter of an HMI

If you can connect communications between an HMI and the Controller when an error occurs, you can check for current Controller errors and the log of past Controller errors.

To perform troubleshooting from an HMI, connect the HMI to the built-in EtherNet/IP port on the CPU Unit.



Precautions for Correct Use

Refer to the appendices of the *NJ/NX-series Troubleshooting Manual* (Cat. No. W503) for the applicable range of the HMI Troubleshooter.

● Current Errors

You can check the current error's event name, event code, level, source, source details, details, and attached information 1 to 4. Observations are not displayed as errors.

● Log of Past Errors

You can check the time of occurrence, level, source, source details, event name, event code, details, attached information 1 to 4 for past errors.

Refer to the relevant HMI manual for information on the HMI Troubleshooter.

Checking with Instructions That Read Function Module Error Status

Instructions are provided that allow you to read the error status of each function module from the user program. These instructions get the status and the event code of the error with the highest level.

Applicable function module	Instruction name	Instruction
PLC Function Module	Get PLC Controller Error Status	GetPLCError
Motion Control Function Module	Get Motion Control Error Status	GetMCErr
EtherCAT Function Module	Get EtherCAT Error Status	GetECErr
EtherNet/IP Function Module	Get EtherNet/IP Error Status	GetEIPError

For details on the instructions that get error status, refer to the *NJ/NX-series Instructions Reference Manual* (Cat. No. W502).

Checking with System-defined Variables

You can check the error status variables in the system-defined variables to determine the status of errors in a Controller. You can read the error status variables from an external device by using communications. Refer to *NJ/NX-series CPU Unit Software User's Manual* (Cat. No. W501) for the system-defined variables.

5-2 Troubleshooting

This section provides basic error identification and troubleshooting flowcharts. Use them when an error occurs in the NX-series Controller. This section also describes the hardware errors that are related to the PLC Function Module and corrections for those errors.

5-2-1 Checking to See If the CPU Unit Is Operating

When an error occurs in the NX-series Controller, use the following flowchart to determine whether the error is a fatal error or a non-fatal error.

Whenever possible, set the Sysmac Studio's communications connection in the flowchart to a direct USB connection. If you use Ethernet, there are many reasons that prevent a communications connection for the Sysmac Studio, so time is required to determine if a fatal or non-fatal error has occurred. If a communications connection from the Sysmac Studio is not possible, perform the troubleshooting procedure that is provided in the *NJ/NX-series Troubleshooting Manual* (Cat. No. W503) before you assume that the error is a fatal error.

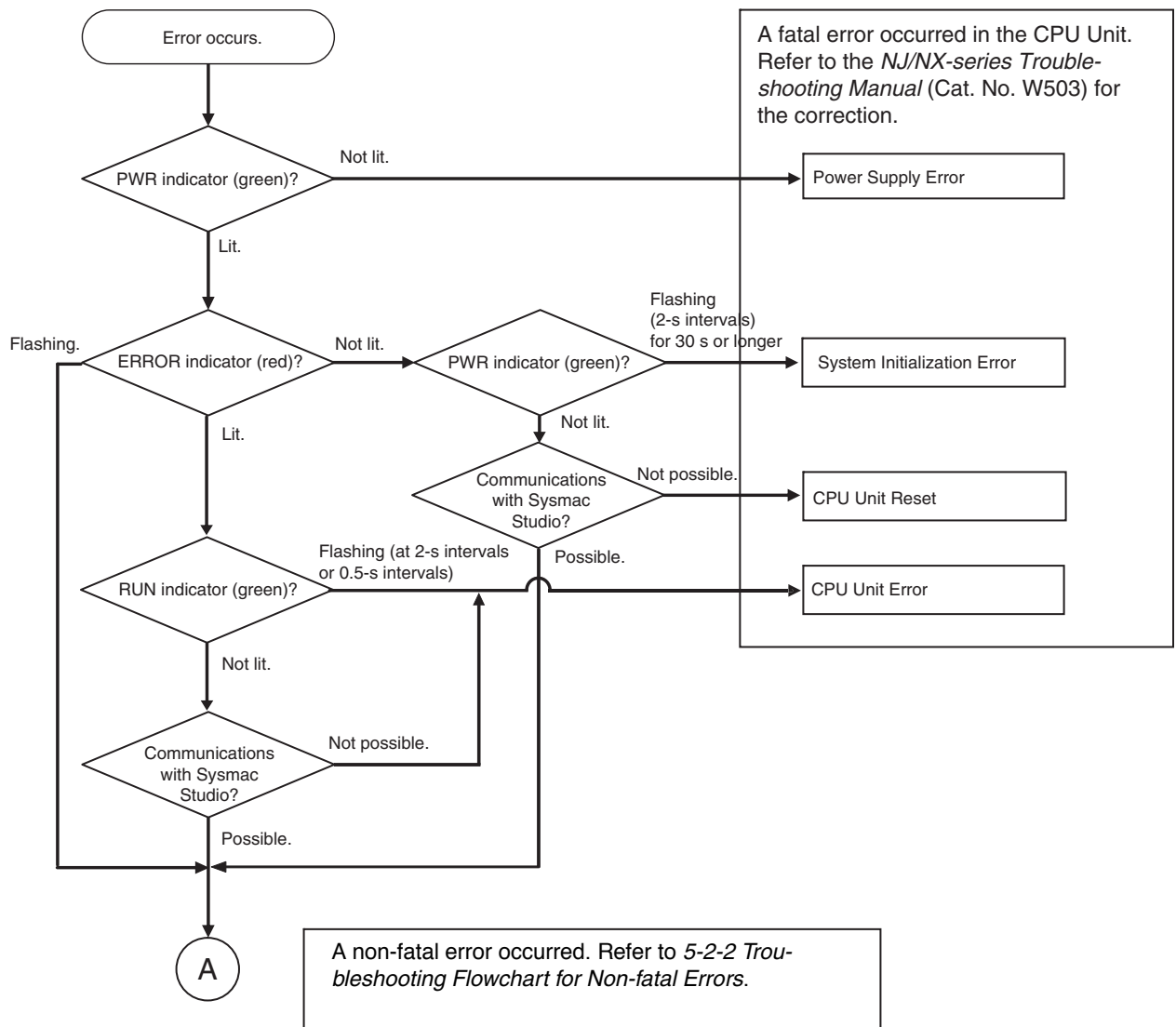

5-2-2 Troubleshooting Flowchart for Non-fatal Errors

For a non-fatal error, use the Sysmac Studio or an HMI to troubleshoot the error with the following flowchart. You can use the indicators to check the following:

- Level
- Whether the error is in the EtherNet/IP port or the EtherCAT port
- If the sources of the error is the EtherNet/IP port or the EtherCAT port, whether you can restore normal status yourself

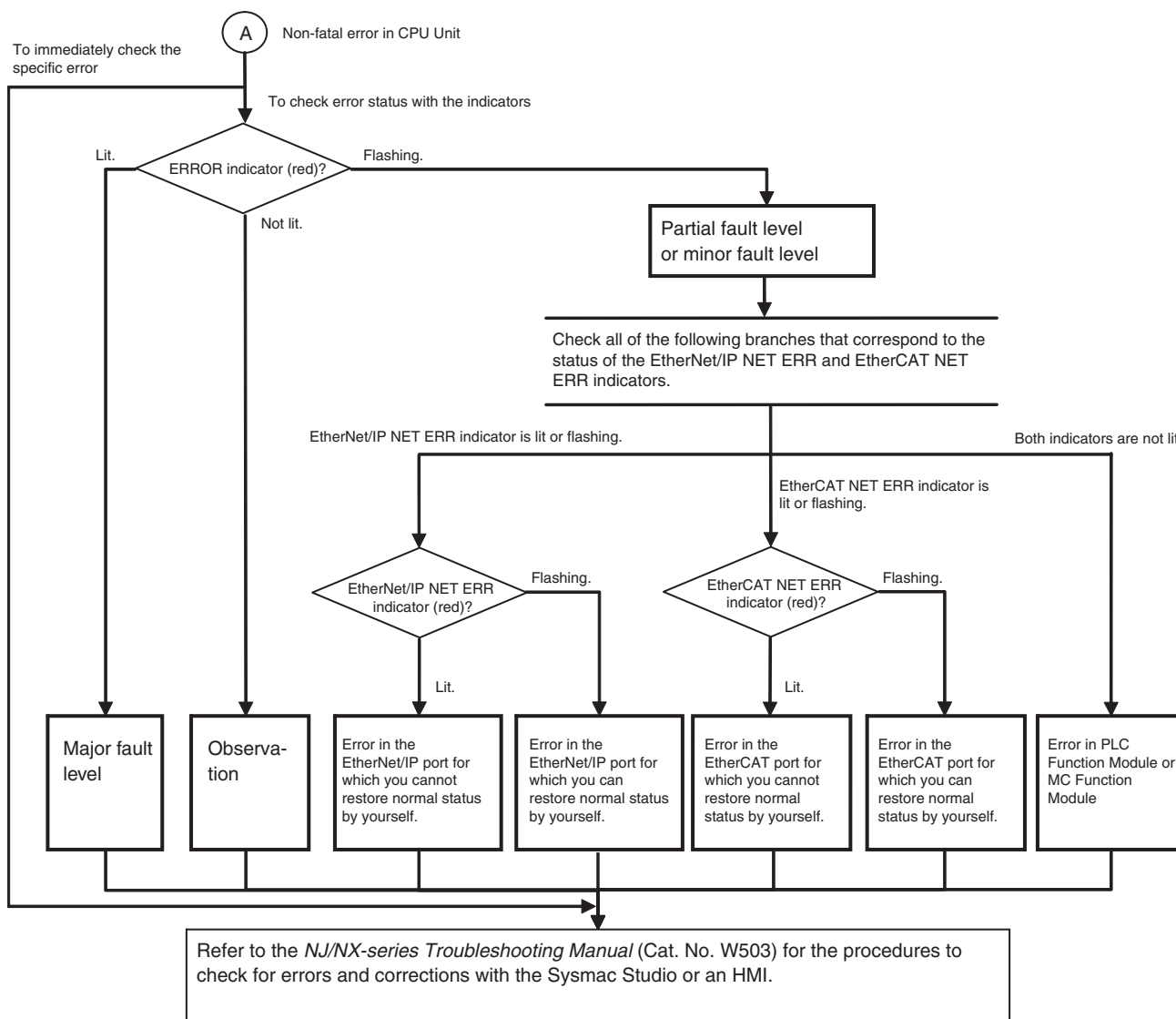

Precautions for Correct Use

Refer to the appendices of the *NJ/NX-series Troubleshooting Manual* (Cat. No. W503) for the applicable range of the HMI Troubleshooter.

5-2-3 Error Table

The hardware errors (i.e., events) and the Controller operation errors (i.e., events) that involve hardware that can occur in the PLC Function Module are given on the following pages. The following abbreviations and symbols are used in the event level column.

Abbreviation	Name
Maj	Major fault level
Prt	Partial fault level
Min	Minor fault level
Obs	Observation
Info	Information

Symbol	Meaning
S	Event levels that are defined by the system.
U	Event levels that can be changed by the user.*

* This symbol appears only for events for which the user can change the event level.

Refer to the *NJ/NX-series Troubleshooting Manual* (Cat. No. W503) for all NX-series event codes.

Errors for Self Diagnosis

Event code	Event name	Meaning	Assumed cause	Level					Reference
				Maj	Prt	Min	Obs	Info	
00090000 hex	DIP Switch Setting Error	An error was detected in the DIP switch setting.	<ul style="list-style-type: none"> There is an error in the DIP switch setting. 	S					page 5-24
000D0000 hex	Internal Bus Check Error	A fatal error was detected on the internal bus.	<ul style="list-style-type: none"> Conductive material has gotten inside. Noise The CPU Unit has failed. 	S					page 5-24
000E0000 hex	Non-volatile Memory Life Exceeded	The specified number of deletions for non-volatile memory was exceeded. Or, the number of bad blocks in memory exceeded the specified value.	<ul style="list-style-type: none"> Non-volatile memory life expired. 	S					page 5-25
00110000 hex	CPU Unit Overheat (Operation Stopped)	Operation was stopped because the temperature inside the CPU Unit was too high.	<ul style="list-style-type: none"> The ambient operating temperature is too high. 	S					page 5-25
10010000 hex	Non-volatile Memory Restored or Formatted	An error was detected in the non-volatile memory check and file system recovery or formatting was executed. Previous files may have been deleted.	<ul style="list-style-type: none"> The Controller power supply was turned OFF while the BUSY indicator was lit. The power supply to the Controller was interrupted momentarily while the BUSY indicator was lit. 	S					page 5-26

Event code	Event name	Meaning	Assumed cause	Level					Reference
				Maj	Prt	Min	Obs	Info	
10020000 hex	Non-volatile Memory Data Corrupted	A file that must be in non-volatile memory is missing or corrupted.	<ul style="list-style-type: none"> The Controller power supply was turned OFF while the BUSY indicator was lit. The power supply to the Controller was interrupted momentarily while the BUSY indicator was lit. The CPU Unit has failed. 	S					page 5-27
10080000 hex	Main Memory Check Error	An error was detected in the memory check of the main memory in the CPU Unit.	<ul style="list-style-type: none"> Conductive material has gotten inside. Noise There is a software error. The CPU Unit has failed. 	S					page 5-28
100A0000 hex	Data Not Saved to Battery-backup Memory	An error occurred in the software and data could not be saved in battery-backup memory during power-OFF processing.	<ul style="list-style-type: none"> An error occurred in the software. 	S					page 5-29
100B0000 hex	Non-volatile Memory Data Corrupted	A file that must be in non-volatile memory is missing or corrupted.	<ul style="list-style-type: none"> The Controller power supply was turned OFF while the BUSY indicator was lit. The power supply to the Controller was interrupted momentarily while the BUSY indicator was lit. The CPU Unit has failed. 	S					page 5-30
100C0000 hex	Event Level Setting Error	The settings in the event level setting file are not correct.	<ul style="list-style-type: none"> The event level settings are not correct because the power supply to the Controller was interrupted or communications with the Sysmac Studio were disconnected during a download of the event level settings. The event level settings are not correct because the power supply to the Controller was interrupted during a Clear All Memory operation. Non-volatile memory failed. 	S					page 5-31
40020000 hex	PLC System Processing Error	A fatal error was detected in the PLC Function Module.	<ul style="list-style-type: none"> An error occurred in the software. 	S					page 5-32
40030000 hex	PLC System Processing Error	A fatal error was detected in the PLC Function Module.	<ul style="list-style-type: none"> An error occurred in the software. 	S					page 5-32
40040000 hex	PLC System Processing Error	A fatal error was detected in the PLC Function Module.	<ul style="list-style-type: none"> An error occurred in the software. 	S					page 5-32
40050000 hex	PLC System Processing Error	A fatal error was detected in the PLC Function Module.	<ul style="list-style-type: none"> An error occurred in the software. 	S					page 5-33
00070000 hex	Real-Time Clock Stopped	The oscillation of the real-time clock stopped. The real-time clock is set to an illegal time.	<ul style="list-style-type: none"> The battery voltage is low. The battery connector has come loose. The Battery is missing. 			S	U		page 5-33
00080000 hex	Real-Time Clock Failed	The real-time clock in the CPU Unit failed.	<ul style="list-style-type: none"> The CPU Unit clock has failed. 			S			page 5-34

Event code	Event name	Meaning	Assumed cause	Level					Reference
				Maj	Prt	Min	Obs	Info	
000B0000 hex	Low Battery Voltage	The voltage of the Battery has dropped.	<ul style="list-style-type: none"> The battery voltage is low. The battery connector has come loose. The Battery is missing. 			S	U		page 5-34
000C0000 hex	CPU Unit Overheat	The temperature inside the CPU Unit exceeded the specified value.	<ul style="list-style-type: none"> The ambient operating temperature is too high. 			S			page 5-35
00120000 hex	Slow Fan	The speed of the fan dropped to a specified level or lower.	<ul style="list-style-type: none"> Something is interfering with fan operation, such as dust, wire scraps, or cuttings. The fan has reached the end of its service life. The fan is faulty. 			S	U		page 5-35
10090000 hex	Battery-backup Memory Check Error	An error was detected in the memory check of the battery-backup memory in the CPU Unit.	<ul style="list-style-type: none"> The battery voltage is low. The battery connector has come loose. The Battery is missing. 			S	U		page 5-36
000F0000 hex	SD Memory Card Invalid Type	The current SD Memory Card is not supported.	<ul style="list-style-type: none"> An SD Memory Card that is not supported was inserted into the CPU Unit. 				S		page 5-36
00100000 hex	SD Memory Card Life Exceeded	The specified number of deletions for the SD Memory Card was exceeded. Or, the number of bad blocks exceeded the specified value.	<ul style="list-style-type: none"> The service life of the SD Memory Card was exceeded. 			U	S		page 5-37
10030000 hex	SD Memory Card Invalid Format	The file format of the SD Memory Card is not FAT16 or FAT32.	<ul style="list-style-type: none"> The file format of the SD Memory Card inserted in the CPU Unit is not FAT16 or FAT32. 				S		page 5-37
10040000 hex	SD Memory Card Restored or Formatted	An error was detected during the file system check and the file system was restored. Files may have been deleted.	<ul style="list-style-type: none"> The Controller power supply was turned OFF while the SD BUSY indicator was lit. The power supply to the Controller was interrupted momentarily while the SD BUSY indicator was lit. The SD Memory Card was removed while the SD PWR indicator was lit. The SD Memory Card is damaged. 			U	S		page 5-38
10060000 hex	SD Memory Card Data Corrupted	A file that must be in the SD Memory Card is missing or corrupted.	<ul style="list-style-type: none"> The Controller power supply was turned OFF while the SD BUSY indicator was lit. The power supply to the Controller was interrupted momentarily while the SD BUSY indicator was lit. The SD Memory Card was removed while the SD PWR indicator was lit. The SD Memory Card is damaged. 			U	S		page 5-39

Event code	Event name	Meaning	Assumed cause	Level					Reference
				Maj	Prt	Min	Obs	Info	
10070000 hex	SD Memory Card Access Power OFF Error	The power supply to the Controller was interrupted during access to the SD Memory Card.	<ul style="list-style-type: none"> The Controller power supply was turned OFF while the SD BUSY indicator was lit. The power supply to the Controller was interrupted momentarily while the SD BUSY indicator was lit. 				S		page 5-39
10310000 hex	Incorrect SD Memory Card Removal	SD Memory Card removal processing failed.	<ul style="list-style-type: none"> The SD Memory Card was removed while the SD PWR indicator was lit. 				S		page 5-40

Errors Related to Controller Operation

Event code	Event name	Meaning	Assumed cause	Level					Reference
				Maj	Prt	Min	Obs	Info	
10200000 hex	User Program/Controller Configurations and Setup Transfer Error	The user program or Controller Configurations and Setup were not transferred correctly.	<ul style="list-style-type: none"> The user program or Controller Configurations and Setup are not correct because the power supply to the Controller was interrupted during a download of the user program or the Controller Configurations and Setup. The user program or Controller Configurations and Setup are not correct because the power supply to the Controller was interrupted during online editing. The user program or Controller Configurations and Setup are not correct because the power supply to the Controller was interrupted during a Clear All Memory operation. The user program or Controller Configurations and Setup are not correct because the power supply to the Controller was interrupted during a restore operation. Non-volatile memory failed. 	S					page 5-41
10210000 hex	Illegal User Program Execution ID	The user program execution IDs set in the user program and in the CPU Unit do not match.	<ul style="list-style-type: none"> The user program execution IDs set in the user program and in the CPU Unit do not match. A user program execution ID is set in the CPU Unit but not in the user program. 	S					page 5-42
10240000 hex	Illegal User Program	The user program is not correct.	<ul style="list-style-type: none"> The limit to the number of nesting levels for functions or function blocks was exceeded. 	S					page 5-42
10250000 hex	Illegal User Program/Controller Configurations and Setup	The upper limit of the usable memory was exceeded or the user program or Controller Configurations and Setup is corrupted.	<ul style="list-style-type: none"> The upper limit of the data size was exceeded. The main memory capacity was exceeded. Non-volatile memory is deteriorating or has failed. 	S					page 5-43

Event code	Event name	Meaning	Assumed cause	Level					Reference
				Maj	Prt	Min	Obs	Info	
10270000 hex	Error in Starting Automatic Transfer	An error was detected in pre-execution checks for automatic transfer.	<ul style="list-style-type: none"> • An SD Memory Card is not inserted. • The SD Memory Card type is not correct. • The format of the SD Memory Card is not correct. • There is no autoloader folder on the SD Memory Card. • There are no backup files in the autoloader folder on the SD Memory Card. • Either the backup files in the autoloader folder on the SD Memory Card are corrupted or required data is not in the backup files on the SD Memory Card. • The unit version of the CPU Unit to which to transfer the files is older than the unit version of the backup files on the SD Memory Card. • The model of the CPU Unit to which to transfer the files is not the same as the model of the CPU Unit of the backup files on the SD Memory Card. • Recovery was executed for the SD Memory Card. • The CPU Unit is write-protected. • The settings in the automatic transfer command file (AutoloadCommand.ini) are not correct. • Reading the data for automatic transfer failed because the SD Memory Card is faulty or not formatted correctly. • The SD Memory Card is damaged. • The database connection service version of the CPU Unit to which to transfer the files is older than the database connection service version of the backup files on the SD Memory Card. • The robot version of the CPU Unit to which to transfer the files is older than the robot version of the backup files on the SD Memory Card. 	S					page 5-44

Event code	Event name	Meaning	Assumed cause	Level					Reference
				Maj	Prt	Min	Obs	Info	
10280000 hex	Error in Executing Automatic Transfer	The automatic transfer ended in an error.	<ul style="list-style-type: none"> It was not possible to read the data for automatic transfer. The SD Memory Card was removed during an automatic transfer. There are no backup files in the autoloader folder on the SD Memory Card. The backup files in the autoloader folder on the SD Memory Card are corrupted. The SD Memory Card is damaged. 	S					page 5-46
40110000 hex	PLC Function Processing Error	A fatal error was detected in the PLC Function Module.	<ul style="list-style-type: none"> An error occurred in the software. 	S					page 5-47
44420000 hex	PLC Function Processing Error	A fatal error was detected in the PLC Function Module.	<ul style="list-style-type: none"> An error occurred in the software. 	S					page 5-47
40120000 hex	PLC Function Processing Error	A fatal error was detected in the PLC Function Module.	<ul style="list-style-type: none"> An error occurred in the software. 		S				page 5-48
40130000 hex	PLC Function Processing Error	A fatal error was detected in part of the PLC Function Module.	<ul style="list-style-type: none"> An error occurred in the software. 			S			page 5-48
10230000 hex	Event Log Save Error	Saving the event log failed.	<ul style="list-style-type: none"> A low battery voltage prevented retention of memory during a power interruption. 				S		page 5-49
10260000 hex	Trace Setting Transfer Failure	The power supply was interrupted while transferring the trace settings.	<ul style="list-style-type: none"> The power supply was interrupted while transferring the trace settings. 				S		page 5-49
10290000 hex	Backup Failed to Start	An error was detected in pre-execution checks for a backup operation.	<ul style="list-style-type: none"> An SD Memory Card is not inserted. The SD Memory Card type is not correct. The format of the SD Memory Card is not correct. The SD Memory Card is write protected. The <i>Prohibiting backing up data to the SD Memory Card</i> parameter is set to prohibit backing up data to an SD Memory Card. Another backup operation is in progress. Synchronization, online editing, or the Clear All Memory operation is in progress. The backup was canceled by the user. The online connection with the Sysmac Studio was disconnected. The SD Memory Card is damaged. 				S		page 5-50

Event code	Event name	Meaning	Assumed cause	Level					Reference
				Maj	Prt	Min	Obs	Info	
102A0000 hex	Backup Failed	The backup operation ended in an error.	<ul style="list-style-type: none"> The capacity of the SD Memory Card is insufficient. It was not possible to save the data that was specified for backup. The SD Memory Card was removed during a backup operation. Failed to back up Unit or slave. The backup was canceled by the user. Execution of the Save Cam Table instruction or changing the CPU Unit name is in progress. The online connection with the Sysmac Studio was disconnected. It was not possible to save the data that was specified for backup to the computer. The SD Memory Card is damaged. 				S		page 5-52

Event code	Event name	Meaning	Assumed cause	Level					Reference
				Maj	Prt	Min	Obs	Info	
102B0000 hex	Restore Operation Failed to Start	An error was detected in pre-execution checks for a restore operation.	<ul style="list-style-type: none"> An SD Memory Card is not inserted. The SD Memory Card type is not correct. The format of the SD Memory Card is not correct. There are no backup files on the SD Memory Card. Either the backup files on the SD Memory Card are corrupted or required data is not in the backup files on the SD Memory Card. The unit version of the CPU Unit to which to restore the files is older than the unit version of the backup files on the SD Memory Card. The model of the CPU Unit to which to restore the files is not the same as the model of the CPU Unit of the backup files on the SD Memory Card. Recovery was executed for the SD Memory Card. The CPU Unit is write-protected. The settings in the restore command file (RestoreCommand.ini) are not correct. A backup operation is in progress. Synchronization, online editing, or the Clear All Memory operation is in progress. The online connection with the Sysmac Studio was disconnected. Reading the data for restoration failed because the SD Memory Card is faulty or not formatted correctly. The SD Memory Card is damaged. The database connection service version of the CPU Unit to which to restore the files is older than the database connection service version of the backup files on the SD Memory Card. The robot version of the CPU Unit to which to restore the files is older than the robot version of the backup files on the SD Memory Card. 				S		page 5-53
102C0000 hex	Restore Operation Failed	The restore operation ended in an error.	<ul style="list-style-type: none"> It was not possible to read the data to restore. The SD Memory Card was removed during a restore operation. Failed to restore Unit or slave. The SD Memory Card is damaged. 				S		page 5-55

Event code	Event name	Meaning	Assumed cause	Level					Reference
				Maj	Prt	Min	Obs	Info	
40140000 hex	PLC System Information	This event provides internal information from the PLC Function Module.	<ul style="list-style-type: none"> This event provides internal information from the PLC Function Module. It is recorded to provide additional information for another event. 				S		page 5-56
40170000 hex	Safe Mode	The Controller started in Safe Mode.	<ul style="list-style-type: none"> The power supply was turned ON to the Controller when Safe Mode was set on the DIP switch on the CPU Unit. 				S		page 5-56
80230000 hex	NX Message Communications Error	An error has occurred in message communications.	<ul style="list-style-type: none"> The communications cable is broken. The communications cable connector is disconnected. The NX message communications load is high. 				S		page 5-57
40150000 hex	PLC System Information	This event provides internal information from the PLC Function Module.	<ul style="list-style-type: none"> This event provides internal information from the PLC Function Module. It is recorded to provide additional information for another event. 					S	page 5-57
44430000 hex	PLC System Information	This event provides internal information from the PLC Function Module.	<ul style="list-style-type: none"> This event provides internal information from the PLC Function Module. It is recorded to provide additional information for another event. 					S	page 5-58
90010000 hex	Clock Changed	The clock time was changed.	<ul style="list-style-type: none"> The clock time was changed. 					S	page 5-58
90020000 hex	Time Zone Changed	The time zone was changed.	<ul style="list-style-type: none"> The time zone was changed. 					S	page 5-58
90050000 hex	User Program/Controller Configurations and Setup Download	The user program and the Controller configurations and setup were downloaded.	<ul style="list-style-type: none"> The user program and the Controller configurations and setup were downloaded. 					S	page 5-59
90070000 hex	Online Edits Transferred	The user program was edited online.	<ul style="list-style-type: none"> The user program was edited online and the edits were transferred to the Controller. 					S	page 5-59
90080000 hex	Variable Changed to TRUE with Forced Refreshing	Changing a variable to TRUE with forced refreshing was specified.	<ul style="list-style-type: none"> Changing a variable to TRUE with forced refreshing was specified by the user. 					S	page 5-60
90090000 hex	Variable Changed to FALSE with Forced Refreshing	Changing a variable to FALSE with forced refreshing was specified.	<ul style="list-style-type: none"> Changing a variable to FALSE with forced refreshing was specified by the user. 					S	page 5-60
900A0000 hex	All Forced Refreshing Cleared	Clearing all forced refreshing values was specified.	<ul style="list-style-type: none"> Clearing all forced refreshing values was specified by the user. 					S	page 5-60
900B0000 hex	Memory All Cleared	All memory was cleared.	<ul style="list-style-type: none"> A user with Administrator rights cleared all of the memory. 					S	page 5-61
900C0000 hex	Event Log Cleared	The event log was cleared.	<ul style="list-style-type: none"> The event log was cleared by the user. 					S	page 5-61
900F0000 hex	Automatic Transfer Completed	The automatic transfer was completed.	<ul style="list-style-type: none"> The automatic transfer was completed. 					S	page 5-61
90110000 hex	Power Turned ON	The power supply was turned ON.	<ul style="list-style-type: none"> The power supply was turned ON. 					S	page 5-62

Event code	Event name	Meaning	Assumed cause	Level					Reference
				Maj	Prt	Min	Obs	Info	
90120000 hex	Power Interrupted	The power supply was interrupted.	<ul style="list-style-type: none"> The power supply was interrupted. 					S	page 5-62
90130000 hex	Operation Started	Operation was started.	<ul style="list-style-type: none"> A command to start operation was received. 					S	page 5-62
90140000 hex	Operation Stopped	Operation was stopped.	<ul style="list-style-type: none"> A command to stop operation was received. 					S	page 5-63
90150000 hex	Reset Executed	A reset was executed.	<ul style="list-style-type: none"> A reset command was received. 					S	page 5-63
90160000 hex	User Program Execution ID Write	The user program execution ID was set or changed in the CPU Unit.	<ul style="list-style-type: none"> A user with Administrator rights changed the user program execution ID that is set in the CPU Unit. 					S	page 5-63
90180000 hex	All Controller Errors Cleared	All current errors were cleared.	<ul style="list-style-type: none"> All current errors were changed by the user. 					S	page 5-64
90190000 hex	Forced Refreshing Cleared	Clearing a forced refreshing value was specified.	<ul style="list-style-type: none"> Clearing a forced refreshing value was specified by the user. 					S	page 5-64
901A0000 hex	Backup Started	A backup operation was started.	<ul style="list-style-type: none"> A backup operation was started. 					S	page 5-64
901B0000 hex	Backup Completed	The backup operation ended normally.	<ul style="list-style-type: none"> The backup operation ended normally. 					S	page 5-65
901C0000 hex	Restore Operation Started	A restore operation started.	<ul style="list-style-type: none"> A restore operation started. 					S	page 5-65
901D0000 hex	Restore Operation Completed	The restore operation ended normally.	<ul style="list-style-type: none"> The restore operation ended normally. 					S	page 5-66

5-2-4 Error Descriptions

This section describes the information that is given for individual errors.

Controller Error Descriptions

The items that are used to describe individual errors (events) are described in the following copy of an error table.

Event name	Gives the name of the error.			Event code	Gives the code of the error.	
Meaning	Gives a short description of the error.					
Source	Gives the source of the error.		Source details	Gives details on the source of the error.	Detection timing	Tells when the error is detected.
Error attributes	Level	Tells the level of influence on control.*1	Recovery	Gives the recovery method.*2	Log category	Tells which log the error is saved in.*3
	User program	Tells what will happen to execution of the user program.*4	Operation	Provides special information on the operation that results from the error.		
Indicators	Gives the status of the built-in EtherNet/IP port and built-in EtherCAT port indicators. Indicator status is given only for errors in the EtherCAT Master Function Module and the EtherNet/IP Function Module.					
System-defined variables	Variable	Data type		Name		
	Lists the variable names, data types, and meanings for system-defined variables that provide direct error notification, that are directly affected by the error, or that contain settings that cause the error.					
Cause and correction	Assumed cause		Correction		Prevention	
	Lists the possible causes, corrections, and preventive measures for the error.					
Attached information	This is the attached information that is displayed by the Sysmac Studio or an HMI.*5					
Precautions/Remarks	Provides precautions, restrictions, and supplemental information. If the user can set the event level, the event levels that can be set, the recovery method, operational information, and other information is also provided.					

*1 One of the following:

Major fault: Major fault level
 Partial fault: Partial fault level
 Minor fault: Minor fault level
 Observation
 Information

*2 One of the following:

Automatic recovery: Normal status is restored automatically when the cause of the error is removed.
 Error reset: Normal status is restored when the error is reset after the cause of the error is removed.
 Cycle the power supply: Normal status is restored when the power supply to the Controller is turned OFF and then back ON after the cause of the error is removed.
 Controller reset: Normal status is restored when the Controller is reset after the cause of the error is removed.
 Depends on cause: The recovery method depends on the cause of the error.

*3 One of the following:

System: System event log
 Access: Access event log

*4 One of the following:

Continues: Execution of the user program will continue.
 Stops: Execution of the user program stops.
 Starts: Execution of the user program starts.

*5 Refer to the appendices of the *NJ/NX-series Troubleshooting Manual* (Cat. No. W503) for the applicable range of the HMI Troubleshooter.

Errors for Self Diagnosis

Event name	DIP Switch Setting Error			Event code	00090000 hex	
Meaning	An error was detected in the DIP switch setting.					
Source	PLC Function Module		Source details	None	Detection timing	At power ON or Controller reset
Error attributes	Level	Major fault	Recovery	Cycle the power supply.	Log category	System
Effects	User program	Stops.	Operation	Stops.*		
System-defined variables	Variable		Data type		Name	
	None		---		---	
Cause and correction	Assumed cause		Correction		Prevention	
	There is an error in the DIP switch setting.		Turn OFF all pins on the DIP switch.		Make sure that the DIP switch settings are correct.	
Attached information	Attached information 1: DIP switch readout value (00000000 hex to 0000000F hex)					
Precautions/Remarks	None					

* For details, refer to *I/O Operation for Major Fault Level Controller Errors* on page 5-7.

Event name	Internal Bus Check Error			Event code	000D0000 hex	
Meaning	A fatal error was detected on the internal bus.					
Source	PLC Function Module		Source details	None	Detection timing	Continuously
Error attributes	Level	Major fault	Recovery	Cycle the power supply.	Log category	System
Effects	User program	Stops.	Operation	Stops.* A connection to the Sysmac Studio may not be possible.		
System-defined variables	Variable		Data type		Name	
	None		---		---	
Cause and correction	Assumed cause		Correction		Prevention	
	Conductive material has gotten inside.		If there is conductive material nearby, blow out the CPU Unit with air.		Do not do any metal working in the vicinity of the control panel. Also, make sure that the operating environment is free of dirt and dust. Close the control panel.	
	Noise <ul style="list-style-type: none"> There is data corruption in bus signals. There is malfunctioning in bus interface circuits. 		If the error occurs even after making the above correction, check the FG, and power supply lines, and other noise entry paths, and implement noise countermeasures as required.		Implement noise countermeasures.	
	The CPU Unit has failed. <ul style="list-style-type: none"> The internal bus is disconnected. 		If this error persists even after you make the above two corrections, replace the CPU Unit.		None	
Attached information	Attached information 1: System information					
Precautions/Remarks	When this error occurs, the CPU Unit stops and the error is recorded in the event log. If cycling the power to the Controller clears the error, you will be able to see whether this error occurred by checking the event log. However, a restart is sometimes not possible depending on the error location.					

* For details, refer to *I/O Operation for Major Fault Level Controller Errors* on page 5-7.

Event name	Non-volatile Memory Life Exceeded			Event code	000E0000 hex	
Meaning	The specified number of deletions for non-volatile memory was exceeded. Or, the number of bad blocks in memory exceeded the specified value.					
Source	PLC Function Module		Source details	None	Detection timing	Continuously
Error attributes	Level	Major fault	Recovery	Cycle the power supply.	Log category	System
Effects	User program	Stops.	Operation	Stops.*		
System-defined variables	Variable		Data type		Name	
	None		---		---	
Cause and correction	Assumed cause		Correction		Prevention	
	Non-volatile memory life expired.		Replace the CPU Unit.		---	
Attached information	None					
Precautions/Remarks	None					

* For details, refer to *I/O Operation for Major Fault Level Controller Errors* on page 5-7.

Event name	CPU Unit Overheat (Operation Stopped)			Event code	00110000 hex	
Meaning	Operation was stopped because the temperature inside the CPU Unit was too high.					
Source	PLC Function Module		Source details	None	Detection timing	Continuously
Error attributes	Level	Major fault	Recovery	Cycle the power supply or reset the Controller.	Log category	System
Effects	User program	Stops.	Operation	Stops.* A connection to the Sysmac Studio is not possible.		
System-defined variables	Variable		Data type		Name	
	None		---		---	
Cause and correction	Assumed cause		Correction		Prevention	
	The ambient operating temperature is too high.		<p>Make sure that the ambient operating temperature stays between 0 and 55°C.</p> <ul style="list-style-type: none"> • Provide enough space for good air flow. • Do not install the Controller directly above equipment that generates a large amount of heat, such as heaters, transformers, or high-capacity resistors. • If the ambient temperature exceeds 55°C, install a cooling fan or air conditioner. 		Make sure that the ambient temperature stays between 0 and 55°C.	
Attached information	None					
Precautions/Remarks	None					

* For details, refer to *I/O Operation for Major Fault Level Controller Errors* on page 5-7.

Event name	Non-volatile Memory Restored or Formatted		Event code	10010000 hex		
Meaning	An error was detected in the non-volatile memory check and file system recovery or formatting was executed. Previous files may have been deleted.					
Source	PLC Function Module		Source details	None	Detection timing	At power ON or Controller reset
Error attributes	Level	Major fault	Recovery	Cycle the power supply or reset the Controller.	Log category	System
Effects	User program	Stops.	Operation	Stops.*		
System-defined variables	Variable		Data type		Name	
	None		---		---	
Cause and correction	Assumed cause		Correction		Prevention	
	<p>The Controller power supply was turned OFF while the BUSY indicator was lit.</p> <p>The power supply to the Controller was interrupted momentarily while the BUSY indicator was lit.</p>		<p>Compare the project with the project on the Sysmac Studio. If they match, cycle the power supply to the Controller or reset the Controller to see if that clears the error. If the error is cleared, check that the device operates correctly.</p> <p>If the comparison shows a mismatch, if the error is not cleared, or if the device does not operate correctly, clear all of memory and then download the project from the Sysmac Studio again. If cycling the power supply to the Controller or resetting the Controller does not clear the error, the memory is corrupted. Replace the CPU Unit.</p> <p>Unexpected operation may occur and can be very dangerous if the power to the Controller is cycled or the Controller is reset before you download the project again.</p>		<p>Do not turn OFF the power supply while the BUSY indicator is lit.</p> <p>Take appropriate measures to ensure that the specified power with the rated voltage and frequency is supplied in places where the power supply is unstable.</p>	
Attached information	Attached information 1: Recovered content (00000000 hex: File system recovery successful, 00000001 hex: Formatted)					
Precautions/Remarks	Make sure that the projects match and that the device operates correctly, or transfer the project again. If you cycle the power to the Controller or reset the Controller before you do this, unexpected operation may occur and can be very dangerous.					

* For details, refer to *I/O Operation for Major Fault Level Controller Errors* on page 5-7.

Event name	Non-volatile Memory Data Corrupted		Event code	10020000 hex		
Meaning	A file that must be in non-volatile memory is missing or corrupted.					
Source	PLC Function Module		Source details	None	Detection timing	At power ON or Controller reset
Error attributes	Level	Major fault	Recovery	Cycle the power supply or reset the Controller.	Log category	System
Effects	User program	Stops.	Operation	Stops.*		
System-defined variables	Variable		Data type		Name	
	None		---		---	
Cause and correction	Assumed cause		Correction		Prevention	
	The Controller power supply was turned OFF while the BUSY indicator was lit.		Clear all of memory and then download the project from the Sysmac Studio.		Do not turn OFF the power supply while the BUSY indicator is lit.	
	The power supply to the Controller was interrupted momentarily while the BUSY indicator was lit.				Take appropriate measures to ensure that the specified power with the rated voltage and frequency is supplied in places where the power supply is unstable.	
	The CPU Unit has failed.		If this error remains even after making the above corrections, replace the CPU Unit.		None	
Attached information	None					
Precautions/Remarks	None					

* For details, refer to *I/O Operation for Major Fault Level Controller Errors* on page 5-7.

Event name	Main Memory Check Error		Event code	10080000 hex		
Meaning	An error was detected in the memory check of the main memory in the CPU Unit.					
Source	PLC Function Module		Source details	None	Detection timing	Continuously
Error attributes	Level	Major fault	Recovery	Cycle the power supply.	Log category	System
Effects	User program	Stops.	Operation	Stops.*		
System-defined variables	Variable		Data type		Name	
	None		---		---	
Cause and correction	Assumed cause		Correction		Prevention	
	Conductive material has gotten inside.		If there is conductive material nearby, blow out the CPU Unit with air.		Do not do any metal working in the vicinity of the control panel. Use the control panel only when it is closed.	
	Noise <ul style="list-style-type: none"> Data corruption in memory Microcomputer malfunctioning Memory write circuit malfunctioning 		If the error did not result from the above causes, cycle the power to the Controller and see if that clears the error. If the error occurs frequently, check the FG, power supply lines, and other noise entry paths, and implement noise countermeasures as required.		Implement noise countermeasures.	
	There is a software error. <ul style="list-style-type: none"> Data corruption was caused by cosmic rays or radiation. 		If the error did not result from the above causes, and cycling the power to the Controller or resetting the Controller does not clear the error, replace the CPU Unit.		None	
	The CPU Unit has failed. <ul style="list-style-type: none"> Memory element failure Memory peripheral circuit failure 				Perform regular inspections.	
Attached information	Attached information 1: System information					
Precautions/Remarks	None					

* For details, refer to *I/O Operation for Major Fault Level Controller Errors* on page 5-7.

Event name	Data Not Saved to Battery-backup Memory		Event code	100A0000 hex		
Meaning	An error occurred in the software and data could not be saved in battery-backup memory during power-OFF processing.					
Source	PLC Function Module		Source details	None	Detection timing	At power ON or Controller reset
Error attributes	Level	Major fault	Recovery	Cycle the power supply.	Log category	System
Effects	User program	Stops.	Operation	Stops.* The variables with a Retain attribute and memory for CJ-series Units in the DM, EM, and Holding Areas do not contain the values from just before the power supply was turned OFF. Unless suitable processing countermeasures are implemented, normal user program execution or normal Unit operation may not be possible when the power is turned ON next time.		
System-defined variables	Variable		Data type		Name	
	None		---		---	
Cause and correction	Assumed cause		Correction		Prevention	
	An error occurred in the software.		Perform the following: <ul style="list-style-type: none"> • Check the values of retained variables and the retained areas in the memory used for CJ-series Units and change them to the correct values. • If the system uses a Servomotor with an absolute encoder, turn ON the power supply, and then turn ON the Servo and check the actual current position of the axis. 		None	
Attached information	None					
Precautions/Remarks	If this error occurs, the values of the following will be the values from the previous time the power supply was turned ON. <ul style="list-style-type: none"> • Retained variables (variables with a Retain attribute or variables in retained areas with AT specifications) • Retained areas in the memory used for CJ-series Units • Absolute encoder home offset data 					

* For details, refer to *I/O Operation for Major Fault Level Controller Errors* on page 5-7.

Event name	Non-volatile Memory Data Corrupted		Event code	100B0000 hex		
Meaning	A file that must be in non-volatile memory is missing or corrupted.					
Source	PLC Function Module		Source details	None	Detection timing	At power ON or Controller reset
Error attributes	Level	Major fault	Recovery	Cycle the power supply or reset the Controller.	Log category	System
Effects	User program	Stops.	Operation	Stops.*		
System-defined variables	Variable		Data type		Name	
	None		---		---	
Cause and correction	Assumed cause		Correction		Prevention	
	The Controller power supply was turned OFF while the BUSY indicator was lit.		Clear all of memory and then download the project from the Sysmac Studio.		Do not turn OFF the power supply while the BUSY indicator is lit.	
	The power supply to the Controller was interrupted momentarily while the BUSY indicator was lit.				Take appropriate measures to ensure that the specified power with the rated voltage and frequency is supplied in places where the power supply is unstable.	
	The CPU Unit has failed.		If this error remains even after making the above corrections, replace the CPU Unit.		None	
Attached information	None					
Precautions/Remarks	None					

* For details, refer to *I/O Operation for Major Fault Level Controller Errors* on page 5-7.

Event name	Event Level Setting Error		Event code	100C0000 hex		
Meaning	The settings in the event level setting file are not correct.					
Source	PLC Function Module		Source details	None	Detection timing	At power ON or Controller reset
Error attributes	Level	Major fault	Recovery	Cycle the power supply or reset the Controller.	Log category	System
Effects	User program	Stops.	Operation	Stops.* ¹		
System-defined variables	Variable		Data type		Name	
	None		---		---	
Cause and correction	Assumed cause		Correction		Prevention	
	The event level settings are not correct because the power supply to the Controller was interrupted or communications with the Sysmac Studio were disconnected during a download of the event level settings.		Perform a Memory All Clear operation and then transfer the event level setting file again.		Do not interrupt the power supply to the Controller or disconnect communications with the Sysmac Studio during a download of the event level settings.	
	The event level settings are not correct because the power supply to the Controller was interrupted during a Clear All Memory operation.				Do not interrupt the power supply to the Controller during a Clear All Memory operation.	
Non-volatile memory failed.		If the error persists even after you make the above correction, replace the CPU Unit.		None		
Attached information	None					
Precautions/Remarks	None					

*1 For details, refer to *I/O Operation for Major Fault Level Controller Errors* on page 5-7.

Event name	PLC System Processing Error		Event code	40020000 hex		
Meaning	A fatal error was detected in the PLC Function Module.					
Source	PLC Function Module		Source details	None	Detection timing	Continuously
Error attributes	Level	Major fault	Recovery	Cycle the power supply.	Log category	System
Effects	User program	Stops.	Operation	Stops.*		
System-defined variables	Variable		Data type		Name	
	None		---		---	
Cause and correction	Assumed cause		Correction		Prevention	
	An error occurred in the software.		Contact your OMRON representative.		None	
Attached information	None					
Precautions/Remarks	None					

* For details, refer to *I/O Operation for Major Fault Level Controller Errors* on page 5-7.

Event name	PLC System Processing Error		Event code	40030000 hex		
Meaning	A fatal error was detected in the PLC Function Module.					
Source	PLC Function Module		Source details	None	Detection timing	Continuously
Error attributes	Level	Major fault	Recovery	Cycle the power supply.	Log category	System
Effects	User program	Stops.	Operation	Stops.*		
System-defined variables	Variable		Data type		Name	
	None		---		---	
Cause and correction	Assumed cause		Correction		Prevention	
	An error occurred in the software.		Contact your OMRON representative.		None	
Attached information	Attached information 1: System information					
Precautions/Remarks	None					

* For details, refer to *I/O Operation for Major Fault Level Controller Errors* on page 5-7.

Event name	PLC System Processing Error		Event code	40040000 hex		
Meaning	A fatal error was detected in the PLC Function Module.					
Source	PLC Function Module		Source details	None	Detection timing	Continuously
Error attributes	Level	Major fault	Recovery	Cycle the power supply.	Log category	System
Effects	User program	Stops.	Operation	Stops.* A connection to the Sysmac Studio is not possible.		
System-defined variables	Variable		Data type		Name	
	None		---		---	
Cause and correction	Assumed cause		Correction		Prevention	
	An error occurred in the software.		Contact your OMRON representative.		None	
Attached information	None					
Precautions/Remarks	None					

* For details, refer to *I/O Operation for Major Fault Level Controller Errors* on page 5-7.

Event name	PLC System Processing Error			Event code	40050000 hex	
Meaning	A fatal error was detected in the PLC Function Module.					
Source	PLC Function Module		Source details	None	Detection timing	Continuously
Error attributes	Level	Major fault	Recovery	Cycle the power supply.	Log category	System
Effects	User program	Stops.	Operation	Stops.* A connection to the Sysmac Studio is not possible.		
System-defined variables	Variable		Data type		Name	
	None		---		---	
Cause and correction	Assumed cause		Correction		Prevention	
	An error occurred in the software.		Contact your OMRON representative.		None	
Attached information	None					
Precautions/Remarks	None					

* For details, refer to *I/O Operation for Major Fault Level Controller Errors* on page 5-7.

Event name	Real-Time Clock Stopped			Event code	00070000 hex	
Meaning	The oscillation of the real-time clock stopped. The real-time clock is set to an illegal time.					
Source	PLC Function Module		Source details	None	Detection timing	At power ON or Controller reset
Error attributes	Level	Minor fault	Recovery	Error reset	Log category	System
Effects	User program	Continues.	Operation	The System Time is not defined. The clock information recorded by CJ-series Units is also not defined.		
System-defined variables	Variable		Data type		Name	
	_CurrentTime		DATE_AND_TIME		System Time	
Cause and correction	Assumed cause		Correction		Prevention	
	The battery voltage is low.		Replace the Battery. Then adjust the real-time clock time.		Regularly replace the Battery.	
	The battery connector has come loose.		Reconnect the connector and make sure it is mated correctly. Then adjust the real-time clock time.		Check for vibration and shock.	
	The Battery is missing.		Install a Battery. Then adjust the real-time clock time.		Install a Battery.	
Attached information	None					
Precautions/Remarks	This error is checked only when the power is turned ON. You can change the event level to the observation level. If you change the level to the observation level, recovery procedures are not required.					

Event name	Real-Time Clock Failed			Event code	00080000 hex	
Meaning	The real-time clock in the CPU Unit failed.					
Source	PLC Function Module		Source details	None	Detection timing	At power ON or Controller reset
Error attributes	Level	Minor fault	Recovery	Cycle the power supply.	Log category	System
Effects	User program	Continues.	Operation	The System Time is not defined. The clock information recorded by CJ-series Units is also not defined.		
System-defined variables	Variable		Data type		Name	
	_CurrentTime		DATE_AND_TIME		System Time	
Cause and correction	Assumed cause		Correction		Prevention	
	The CPU Unit clock has failed.		Replace the CPU Unit.		None	
Attached information	None					
Precautions/Remarks	None					

Event name	Low Battery Voltage			Event code	000B0000 hex	
Meaning	The voltage of the Battery has dropped.					
Source	PLC Function Module		Source details	None	Detection timing	Continuously
Error attributes	Level	Minor fault	Recovery	Error reset	Log category	System
Effects	User program	Continues.	Operation	No affected		
System-defined variables	Variable		Data type		Name	
	_SelfTest_LowBattery		BOOL		Low Battery Flag	
Cause and correction	Assumed cause		Correction		Prevention	
	The battery voltage is low.		Replace the Battery.		Regularly replace the Battery.	
	The battery connector has come loose.		Reconnect the connector and make sure it is mated correctly.		Check for vibration and shock.	
	The Battery is missing.		Install a Battery.		Install a Battery.	
Attached information	None					
Precautions/Remarks	You may lose the user data the next time that the power supply is interrupted. You can change the event level to the observation level. If you change the level to the observation level, recovery procedures are not required.					

Event name	CPU Unit Overheat			Event code	000C0000 hex	
Meaning	The temperature inside the CPU Unit exceeded the specified value.					
Source	PLC Function Module		Source details	None	Detection timing	Continuously
Error attributes	Level	Minor fault	Recovery	Cycle the power supply or reset the Controller.	Log category	System
Effects	User program	Continues.	Operation	Not affected.		
System-defined variables	Variable		Data type		Name	
	_SelfTest_HighTemperature		BOOL		CPU Unit High Temperature Flag	
Cause and correction	Assumed cause		Correction		Prevention	
	The ambient operating temperature is too high.		<p>Make sure that the ambient operating temperature stays between 0 and 55°C.</p> <ul style="list-style-type: none"> • Provide enough space for good air flow. • Do not install the Controller above equipment that generates a large amount of heat, such as heaters, transformers, or high-capacity resistors. • If the ambient temperature exceeds 55°C, install a cooling fan or air conditioner. 		Make sure that the ambient temperature stays between 0 and 55°C.	
Attached information	None					
Precautions/Remarks	None					

Event name	Slow Fan			Event code	00120000 hex	
Meaning	The speed of the fan dropped to a specified level or lower.					
Source	PLC Function Module		Source details	None	Detection timing	Continuously
Error attributes	Level	Minor fault	Recovery	Error reset	Log category	System
Effects	User program	Continues.	Operation	Operation is not affected.		
System-defined variables	Variable		Data type		Name	
	_SelfTest_LowFanRevolution		BOOL		Low Fan Revolution Flag	
Cause and correction	Assumed cause		Correction		Prevention	
	Something is interfering with fan operation, such as dust, wire scraps, or cuttings.		Remove the material that is interfering with fan operation.		Make sure that nothing is interfering with the fan during operation.	
	The fan has reached the end of its service life.		Replace the Fan Unit.*		Regularly replace the Fan Unit.*	
The fan is faulty.						
Attached information	None					
Precautions/Remarks	You can change the event level to the observation level. If you change the level to the observation level, recovery procedures are not required.					

* Refer to NTLPxREF 7-3 *Replacing the Fan Unit* on page 7-3 for the Fan Unit replacement procedure and life.

Event name	Battery-backup Memory Check Error		Event code	10090000 hex		
Meaning	An error was detected in the memory check of the battery-backup memory in the CPU Unit.					
Source	PLC Function Module or Motion Control Function Module		Source details	PLC Function Module: None Motion Control Function Module: MC Common	Detection timing	At power ON or Controller reset
Error attributes	Level	Minor fault	Recovery	Error reset	Log category	System
Effects	User program	Continues.	Operation	The variables with a Retain attribute and memory for CJ-series Units in the DM, EM, and Holding Areas were corrupted. Normal user program execution or normal Unit operation may not be possible.		
System-defined variables	Variable		Data type		Name	
	_RetainFail		BOOL		Retention Failure Flag	
Cause and correction	Assumed cause		Correction		Prevention	
	The battery voltage is low.		Replace the Battery.		Regularly replace the Battery.	
	The battery connector has come loose.		Reconnect the connector and make sure it is mated correctly.		Check for vibration and shock.	
	The Battery is missing.		Install a Battery.		Install a Battery.	
Attached information	None					
Precautions/Remarks	After you implement the above countermeasures, set the correct data for the variables with a Retain attribute and memory for CJ-series Units in the DM, EM, and Holding Areas. You can change the event level to the observation level. If you change the level to the observation level, recovery procedures are not required.					

Event name	SD Memory Card Invalid Type		Event code	000F0000 hex		
Meaning	The current SD Memory Card is not supported.					
Source	PLC Function Module		Source details	None	Detection timing	At power ON, at Controller reset, or when SD Memory Card is inserted
Error attributes	Level	Observation	Recovery	---	Log category	System
Effects	User program	Continues.	Operation	SD PWR indicator is not lit. Power supply to SD Memory Card is stopped.		
System-defined variables	Variable		Data type		Name	
	_Card1Ready		BOOL		SD Memory Card Ready Flag	
Cause and correction	Assumed cause		Correction		Prevention	
	An SD Memory Card that is not supported was inserted into the CPU Unit.		Replace the SD Memory Card with an SD/SDHC card with a capacity of 32 GB or less.		Use an SD/SDHC card with a capacity of 32 GB or less for the SD Memory Card.	
Attached information	None					
Precautions/Remarks	None					

Event name	SD Memory Card Life Exceeded			Event code	00100000 hex	
Meaning	The specified number of deletions for the SD Memory Card was exceeded. Or, the number of bad blocks exceeded the specified value.					
Source	PLC Function Module		Source details	None	Detection timing	At power ON, at Controller reset, or periodically
Error attributes	Level	Observation	Recovery	---	Log category	System
Effects	User program	Continues.	Operation	Not affected.		
System-defined variables	Variable		Data type		Name	
	_Card1Deteriorated		BOOL		SD Memory Card Life Warning Flag	
Cause and correction	Assumed cause		Correction		Prevention	
	The service life of the SD Memory Card was exceeded.		Back up necessary files in the SD Memory Card. Or replace the SD Memory Card.		Regularly replace the SD Memory Card.	
Attached information	None					
Precautions/Remarks	The data on the SD Memory Card may be corrupted. Normal user program operation may not be possible. You can change the event level to the minor fault level. If you change the level to the minor fault level, the Recovery column above will be changed to "Error reset."					

Event name	SD Memory Card Invalid Format			Event code	10030000 hex	
Meaning	The file format of the SD Memory Card is not FAT16 or FAT32.					
Source	PLC Function Module		Source details	None	Detection timing	At power ON, at Controller reset, or when SD Memory Card is inserted
Error attributes	Level	Observation	Recovery	---	Log category	System
Effects	User program	Continues.	Operation	SD PWR indicator is not lit. You can format the SD Memory Card from the Sysmac Studio.		
System-defined variables	Variable		Data type		Name	
	_Card1Ready		BOOL		SD Memory Card Ready Flag	
Cause and correction	Assumed cause		Correction		Prevention	
	The file format of the SD Memory Card inserted in the CPU Unit is not FAT16 or FAT32.		Make sure that the correct SD Memory Card is inserted in the CPU Unit. If an incorrect SD Memory Card is inserted, replace it with the correct one. If the correct SD Memory Card is inserted, format it correctly before you use it.		Use an OMRON SD Memory Card. Do not format the SD Memory Card on a computer.	
Attached information	None					
Precautions/Remarks	None					

Event name	SD Memory Card Restored or Formatted		Event code	10040000 hex	
Meaning	An error was detected during the file system check and the file system was restored. Files may have been deleted.				
Source	PLC Function Module		Source details	None	At power ON or Controller reset
Error attributes	Level	Observation	Recovery	---	System
Effects	User program	Continues.	Operation	If the file is deleted, normal user program operation may not be possible.	
System-defined variables	Variable		Data type		Name
	None		---		---
Cause and correction	Assumed cause		Correction		Prevention
	The Controller power supply was turned OFF while the SD BUSY indicator was lit.		Check that the correct file is on the SD Memory Card, or that the device operates correctly. If the correct file is not on the SD Memory Card, or if the device does not operate correctly, download the correct file to the SD Memory Card. Cycle the power supply to the Controller or reset the Controller and confirm that the system operates correctly.		Do not turn OFF the power supply while the SD BUSY indicator is lit.
	The power supply to the Controller was interrupted momentarily while the SD BUSY indicator was lit.				Take appropriate measures to ensure that the specified power with the rated voltage and frequency is supplied in places where the power supply is unstable.
	The SD Memory Card was removed while the SD PWR indicator was lit.				Do not remove the SD Memory Card while the SD PWR indicator is lit.
	The SD Memory Card is damaged.		If this error occurs even though the above problem does not exist, replace the SD Memory Card and download the correct files to it.		None
Attached information	None				
Precautions/Remarks	The error is detected at power ON or at a Controller reset only when SD Memory Card diagnosis at startup is enabled. You can change the event level to the minor fault level. If you change the level to the minor fault level, the Recovery column above will be changed to "Error reset."				

Event name	SD Memory Card Data Corrupted			Event code	10060000 hex
Meaning	A file that must be in the SD Memory Card is missing or corrupted.				
Source	PLC Function Module		Source details	None	Detection timing At power ON or Controller reset
Error attributes	Level	Observation	Recovery	---	Log category System
Effects	User program	Continues.	Operation	SD PWR indicator is not lit. You can format the SD Memory Card from the Sysmac Studio. Normal user program operation may not be possible.	
System-defined variables	Variable		Data type		Name
	_Card1Ready		BOOL		SD Memory Card Ready Flag
Cause and correction	Assumed cause		Correction		Prevention
	The Controller power supply was turned OFF while the SD BUSY indicator was lit.		Format the SD Memory Card and download the correct file.		Do not turn OFF the power supply while the SD BUSY indicator is lit.
	The power supply to the Controller was interrupted momentarily while the SD BUSY indicator was lit.				Take appropriate measures to ensure that the specified power with the rated voltage and frequency is supplied in places where the power supply is unstable.
	The SD Memory Card was removed while the SD PWR indicator was lit.		If the error cannot be cleared with the above corrections, replace the SD Memory Card with one that operates normally.		Do not remove the SD Memory Card while the SD PWR indicator is lit.
The SD Memory Card is damaged.		None			
Attached information	None				
Precautions/Remarks	The error is detected at power ON or at a Controller reset only when SD Memory Card diagnosis at startup is enabled. You can change the event level to the minor fault level. If you change the level to the minor fault level, the Recovery column above will be changed to "Error reset."				

Event name	SD Memory Card Access Power OFF Error			Event code	10070000 hex
Meaning	The power supply to the Controller was interrupted during access to the SD Memory Card.				
Source	PLC Function Module		Source details	None	Detection timing At power ON or Controller reset
Error attributes	Level	Observation	Recovery	---	Log category System
Effects	User program	Continues.	Operation	Operation is controlled by the user program when the file is corrupted.	
System-defined variables	Variable		Data type		Name
	_Card1PowerFail		BOOL		SD Memory Card Power Interruption Flag
Cause and correction	Assumed cause		Correction		Prevention
	The Controller power supply was turned OFF while the SD BUSY indicator was lit.		Check that the correct file is on the SD Memory Card, or that the device operates correctly. If the correct file is not on the SD Memory Card, or if the device does not operate correctly, download the correct file to the SD Memory Card. Cycle the power supply to the Controller or reset the Controller and confirm that the system operates correctly. When you have finished the corrections, set the SD Memory Card Access Power Interruption Flag (_Card1PowerFail) to FALSE.		Do not turn OFF the power supply while the SD BUSY indicator is lit.
	The power supply to the Controller was interrupted momentarily while the SD BUSY indicator was lit.				Take appropriate measures to ensure that the specified power with the rated voltage and frequency is supplied in places where the power supply is unstable.
Attached information	None				
Precautions/Remarks	When the measure is completed, change the SD Memory Card Access Power Interruption Flag to FALSE.				

Event name	Incorrect SD Memory Card Removal			Event code	10310000 hex	
Meaning	SD Memory Card removal processing failed.					
Source	PLC Function Module		Source details	None	Detection timing	At SD Memory Card removal
Error attributes	Level	Observation	Recovery	---	Log category	System
Effects	User program	Continues.	Operation	Not affected.		
System-defined variables	Variable		Data type		Name	
	None		---		---	
Cause and correction	Assumed cause		Correction		Prevention	
	The SD Memory Card was removed while the SD PWR indicator was lit.		Check the files on the SD Memory Card to see if they are correct. If the files on the SD Memory Card are not correct, download the correct files to the SD Memory Card.		Press the SD Memory Card power supply switch and confirm that the SD PWR indicator goes out before you remove the SD Memory Card.	
Attached information	None					
Precautions/Remarks	None					

Errors Related to Controller Operation

Event name	User Program/Controller Configurations and Setup Transfer Error		Event code	10200000 hex		
Meaning	The user program or Controller Configurations and Setup were not transferred correctly.					
Source	PLC Function Module		Source details	None or I/O bus master	Detection timing	At power ON or Controller reset
Error attributes	Level	Major fault	Recovery	Cycle the power supply or reset the Controller.	Log category	System
Effects	User program	Stops.	Operation	Stops.*		
System-defined variables	Variable		Data type		Name	
	None		---		---	
Cause and correction	Assumed cause		Correction		Prevention	
	The user program or Controller Configurations and Setup are not correct because the power supply to the Controller was interrupted during a download of the user program or the Controller Configurations and Setup.		Clear all of memory and then download the project from the Sysmac Studio. If attached information is registered, cycle the power supply to the Controller and then implement the above correction.		Do not turn OFF the power supply to the Controller during a download of the user program or the Controller Configurations and Setup.	
	The user program or Controller Configurations and Setup are not correct because the power supply to the Controller was interrupted during online editing.		If you cannot perform a Clear All Memory operation from the Sysmac Studio, transfer the project to the Controller with a restore operation from an SD Memory Card.		Do not interrupt the power supply to the Controller during online editing.	
	The user program or Controller Configurations and Setup are not correct because the power supply to the Controller was interrupted during a Clear All Memory operation.				Do not interrupt the power supply to the Controller during a Clear All Memory operation.	
	The user program or Controller Configurations and Setup are not correct because the power supply to the Controller was interrupted during a restore operation.				Do not interrupt the power supply to the Controller during a restore operation.	
Non-volatile memory failed.		If the error persists even after you make the above correction, replace the CPU Unit.		None		
Attached information	Attached Information 1: Cause Details None: Power was interrupted during a download, during online editing, or during restoration. Downloading/Predownloading: For other causes, the timing of error occurrence (during download or during download preparations) is given.					
Precautions/Remarks	None					

* For details, refer to *I/O Operation for Major Fault Level Controller Errors* on page 5-7.

Event name	Illegal User Program Execution ID		Event code	10210000 hex		
Meaning	The user program execution IDs set in the user program and in the CPU Unit do not match.					
Source	PLC Function Module		Source details	None	Detection timing	At user program download, power ON, or Controller reset
Error attributes	Level	Major fault	Recovery	Cycle the power supply or reset the Controller.	Log category	System
Effects	User program	Stops.	Operation	Stops.*		
System-defined variables	Variable		Data type		Name	
	None		---		---	
Cause and correction	Assumed cause		Correction		Prevention	
	The user program execution IDs set in the user program and in the CPU Unit do not match.		Set the same user program execution ID in the user program and CPU Unit.		Set the same user program execution ID in the user program and CPU Unit. Keep a record of the user program execution IDs set in the user program and in the CPU Unit. They are not displayed.	
	A user program execution ID is set in the CPU Unit but not in the user program.		If user program execution ID is not set in the user program, clear the user program execution ID set in the CPU Unit by clearing all memory in the CPU Unit.			
Attached information	None					
Precautions/Remarks	None					

* For details, refer to *I/O Operation for Major Fault Level Controller Errors* on page 5-7.

Event name	Illegal User Program		Event code	10240000 hex		
Meaning	The user program is not correct.					
Source	PLC Function Module		Source details	None	Detection timing	At download, power ON, or Controller reset
Error attributes	Level	Major fault	Recovery	Cycle the power supply or reset the Controller.	Log category	System
Effects	User program	Stops.	Operation	Stops.*		
System-defined variables	Variable		Data type		Name	
	None		---		---	
Cause and correction	Assumed cause		Correction		Prevention	
	The limit to the number of nesting levels for functions or function blocks was exceeded.		Find the location in the user program that exceeds the limit to the number of nesting levels for functions or function blocks and reduce the number of nesting levels to within the limit. Then, download the user program again.		Write the user program so that the limit to the number of nesting levels for functions or function blocks is not exceeded. Use the program check on the Sysmac Studio to confirm that the limit to the number of nesting levels is not exceeded.	
Attached information	None					
Precautions/Remarks	None					

* For details, refer to *I/O Operation for Major Fault Level Controller Errors* on page 5-7.

Event name	Illegal User Program/Controller Configurations and Setup		Event code	10250000 hex		
Meaning	The upper limit of the usable memory was exceeded or the user program or Controller Configurations and Setup is corrupted.					
Source	PLC Function Module		Source details	None	Detection timing	At download, power ON, or Controller reset
Error attributes	Level	Major fault	Recovery	Cycle the power supply or reset the Controller.	Log category	System
Effects	User program	Stops.	Operation	Stops.*		
System-defined variables	Variable		Data type		Name	
	None		---		---	
Cause and correction	Assumed cause		Correction		Prevention	
	The upper limit of the data size was exceeded.		If an event on restrictions on the number of items used occurred at the same time as this event, correct the user program and settings so that the number of items used is not exceeded and then download the data again.		None	
	The main memory capacity was exceeded.		If an event on restrictions on the number of items used did not occur at the same time as this event, perform the Clear All Memory operation, cycle the power supply, and then confirm that this event was cleared. If it was cleared, reduce the size of the project, e.g., by sharing programming, and then download the project again.			
	Non-volatile memory is deteriorating or has failed.		If this error persists even after you implement the above two corrections, replace the CPU Unit.			
Attached information	None					
Precautions/Remarks	None					

* For details, refer to *I/O Operation for Major Fault Level Controller Errors* on page 5-7.

Event name	Error in Starting Automatic Transfer		Event code	10270000 hex	
Meaning	An error was detected in pre-execution checks for automatic transfer.				
Source	PLC Function Module		Source details	None	At power ON
Error attributes	Level	Major fault	Recovery	Cycle the power supply or reset the Controller.	System
Effects	User program	Stops.	Operation	Stops.*1	
System-defined variables	Variable		Data type		Name
	None		---		---
Cause and correction	Assumed cause		Correction		Prevention
	An SD Memory Card is not inserted.		Insert an SD Memory Card.		Insert an SD Memory Card.
	The SD Memory Card type is not correct.		Replace the SD Memory Card with an SD or SDHC card.		Use an SD or SDHC card.
	The format of the SD Memory Card is not correct.		Format the SD Memory Card with the Sysmac Studio and then create an autoload folder and place the backup files in it.		Use a formatted SD Memory Card, create an autoload folder on the SD Memory Card, and place the backup files in it. Also, do not remove the SD Memory Card or turn OFF the power supply while the SD BUSY indicator is lit.
	There is no autoload folder on the SD Memory Card.		Create an autoload folder on the SD Memory Card and place the backup files in it.		
	There are no backup files in the autoload folder on the SD Memory Card.		Place the backup files in the autoload folder on the SD Memory Card.		
	Either the backup files in the autoload folder on the SD Memory Card are corrupted or required data is not in the backup files on the SD Memory Card.		Replace the backup files in the autoload folder on the SD Memory Card. If this error occurs again even after replacing the files, create the backup files again and place them in the autoload folder.		
The unit version of the CPU Unit to which to transfer the files is older than the unit version of the backup files on the SD Memory Card.		Replace the CPU Unit with a CPU Unit that has a unit version that is the same as or newer than the unit version of the CPU that was used to create the backup files. Or, place the backup files with the correct unit version for the CPU Unit in the autoload folder.			
				Make sure that the unit version of the CPU Unit and the unit version of the backup files are compatible.	

Cause and correction	The model of the CPU Unit to which to transfer the files is not the same as the model of the CPU Unit of the backup files on the SD Memory Card.	Replace the CPU Unit with a CPU Unit that has the same model as the CPU Unit that was used to create the backup files. Or, place the backup files with the same model of CPU Unit in the autoload folder.	Make sure that the model of the CPU Unit is the same as the model of the CPU Unit that was used to create the backup files.
	Recovery was executed for the SD Memory Card.	If there are no backup files or no automatic transfer command file in the autoload folder, place the files in the folder again.	None
	The CPU Unit is write-protected.	If you use automatic transfers, select the <i>Do not use</i> Option for the <i>Write protection at startup</i> setting of the CPU Unit.	If you use automatic transfers, select the <i>Do not use</i> Option for the <i>Write protection at startup</i> setting of the CPU Unit.
	The settings in the automatic transfer command file (AutoloadCommand.ini) are not correct.	Make sure that the required files are set to "Yes" in the automatic transfer command file.	Make sure that the required files are set to "Yes" in the automatic transfer command file.
	Reading the data for automatic transfer failed because the SD Memory Card is faulty or not formatted correctly.	Perform the same corrective measures as for when the format of the SD Memory Card is not correct or the SD Memory Card is damaged.	Perform the same preventive measures as for the following events: SD Memory Card Invalid Format or Faulty SD Memory Card.
	The SD Memory Card is damaged.	If none of the above causes applies, replace the SD Memory Card.	Do not remove the SD Memory Card or turn OFF the power supply while the SD BUSY indicator is lit. Or, replace the SD Memory Card periodically according to the write life of the SD Memory Card.
	The database connection service version of the CPU Unit to which to transfer the files is older than the database connection service version of the backup files on the SD Memory Card.	Replace the CPU Unit with a CPU Unit that has a database connection service version that is the same as or newer than the database connection service version of the CPU Unit that was used to create the backup files. Or, place the backup files with the correct database connection service version for the CPU Unit in the autoload folder.	Make sure that the database connection service version of the CPU Unit and the database connection service version of the backup files are compatible.
	The robot version of the CPU Unit to which to transfer the files is older than the robot version of the backup files on the SD Memory Card.	Replace the CPU Unit with a CPU Unit that has a robot version that is the same as or newer than the robot version of the CPU Unit that was used to create the backup files. Or, place the backup files with the correct robot version for the CPU Unit in the autoload folder.	Make sure that the robot version of the CPU Unit and the robot version of the backup files are compatible.
Attached information	<p>Attached Information 1: Error Details</p> <p>0001 hex:An SD Memory Card is not inserted.</p> <p>0002 hex:The SD Memory Card is faulty, the format of the SD Memory Card is not correct, or the SD Memory Card is not the correct type of card.</p> <p>0004 hex:Recovery was executed for the SD Memory Card.</p> <p>0101 hex:There is no autoload folder on the SD Memory Card.</p> <p>0102 hex:There are no backup files in the autoload folder on the SD Memory Card.</p> <p>0103 hex:The backup files are corrupted.</p> <p>0104 hex:The contents of the automatic transfer command file are not correct.</p> <p>0105 hex:The required transfer data is not in the backup file.</p> <p>0201 hex:The unit version of the CPU Unit is old.</p> <p>0202 hex:The model numbers of the CPU Unit are not the same.</p> <p>0203 hex:The CPU Unit is write-protected.</p> <p>0211 hex: The database connection service or robot version of the CPU Unit is old.</p> <p>0301 hex:Reading data for automatic transfer failed or the SD Memory Card is faulty.</p>		
Precautions/Remarks	None		

*1 For details, refer to *I/O Operation for Major Fault Level Controller Errors* on page 5-7.

Event name	Error in Executing Automatic Transfer		Event code	10280000 hex		
Meaning	The automatic transfer ended in an error.					
Source	PLC Function Module		Source details	None	Detection timing	At power ON
Error attributes	Level	Major fault	Recovery	Cycle the power supply or reset the Controller.	Log category	System
Effects	User program	Stops.	Operation	Stops.*1		
System-defined variables	Variable		Data type		Name	
	None		---		---	
Cause and correction	Assumed cause		Correction		Prevention	
	It was not possible to read the data for automatic transfer.		Format the SD Memory Card with the Sysmac Studio and then create an autoloading folder and place the backup files in it.		Do not remove the SD Memory Card or turn OFF the power supply while the SD BUSY indicator is lit. Replace the SD Memory Card periodically according to the write life of the SD Memory Card.	
	The SD Memory Card was removed during an automatic transfer.		Insert an SD Memory Card that contains the backup files in an autoloading folder, and then cycle the power supply to execute the automatic transfer again.		Do not remove the SD Memory Card during the automatic transfer.	
	There are no backup files in the autoloading folder on the SD Memory Card.		Create an autoloading folder in the SD Memory Card and store the backup files in it.		Use a formatted SD Memory Card, create an autoloading folder in the SD Memory Card, and store the backup files in the folder. Do not turn OFF the power supply or remove the SD Memory Card while the SD BUSY indicator is lit.	
	The backup files in the autoloading folder on the SD Memory Card are corrupted.		Store the backup files in the autoloading folder again. If this error occurs again even after replacing the files, create the backup files again and place them in the autoloading folder.			
	The SD Memory Card is damaged.		If none of the above causes applies, replace the SD Memory Card.		Do not remove the SD Memory Card or turn OFF the power supply while the SD BUSY indicator is lit. Replace the SD Memory Card periodically according to the write life of the SD Memory Card.	
Attached information	Attached Information 1: Error Details 0001 hex: The SD Memory Card was removed. 0102 hex: There are no backup files in the autoloading folder on the SD Memory Card. 0103 hex: The backup files are corrupted. 0301 hex: Reading data for automatic transfer failed or the SD Memory Card is damaged.					
Precautions/Remarks	None					

*1 For details, refer to *I/O Operation for Major Fault Level Controller Errors* on page 5-7.

Event name	PLC Function Processing Error			Event code	40110000 hex	
Meaning	A fatal error was detected in the PLC Function Module.					
Source	PLC Function Module		Source details	None	Detection timing	Continuously
Error attributes	Level	Major fault	Recovery	Cycle the power supply.	Log category	System
Effects	User program	Stops.	Operation	Stops.*		
System-defined variables	Variable		Data type		Name	
	None		---		---	
Cause and correction	Assumed cause		Correction		Prevention	
	An error occurred in the software.		Contact your OMRON representative.		None	
Attached information	Attached information 1: System information Attached Information 2: System information Attached information 3: System information Attached information 4: System information					
Precautions/Remarks	None					

* For details, refer to *I/O Operation for Major Fault Level Controller Errors* on page 5-7.

Event name	PLC Function Processing Error			Event code	44420000 hex	
Meaning	A fatal error was detected in the PLC Function Module.					
Source	PLC Function Module		Source details	None	Detection timing	Continuously
Error attributes	Level	Major fault	Recovery	Cycle the power supply or reset the Controller.	Log category	System
Effects	User program	Stops.	Operation	Stops.* ¹		
System-defined variables	Variable		Data type		Name	
	None		---		---	
Cause and correction	Assumed cause		Correction		Prevention	
	An error occurred in the software.		Contact your OMRON representative.		None	
Attached information	Attached information 1: System information Attached Information 2: System information Attached information 3: System information Attached information 4: System information					
Precautions/Remarks	None					

*¹ For details, refer to *I/O Operation for Major Fault Level Controller Errors* on page 5-7.

Event name	PLC Function Processing Error		Event code	40120000 hex		
Meaning	A fatal error was detected in the PLC Function Module.					
Source	PLC Function Module		Source details	None	Detection timing	Continuously
Error attributes	Level	Partial fault	Recovery	Cycle the power supply.	Log category	System
Effects	User program	Stops.	Operation	Stops.*1		
System-defined variables	Variable		Data type		Name	
	None		---		---	
Cause and correction	Assumed cause		Correction		Prevention	
	An error occurred in the software.		Contact your OMRON representative.		None	
Attached information	Attached information 1: System information Attached Information 2: System information Attached information 3: System information Attached information 4: System information					
Precautions/Remarks	None					

*1 Operation is the same as for a major fault level error. For details, refer to *I/O Operation for Major Fault Level Controller Errors* on page 5-7.

Event name	PLC Function Processing Error		Event code	40130000 hex		
Meaning	A fatal error was detected in part of the PLC Function Module.					
Source	PLC Function Module		Source details	None	Detection timing	Continuously
Error attributes	Level	Minor fault	Recovery	Cycle the power supply or reset the Controller.	Log category	System
Effects	User program	Continues.	Operation	Operation is not affected.		
System-defined variables	Variable		Data type		Name	
	None		---		---	
Cause and correction	Assumed cause		Correction		Prevention	
	An error occurred in the software.		Contact your OMRON representative.		None	
Attached information	Attached information 1: System information Attached Information 2: System information Attached information 3: System information Attached information 4: System information					
Precautions/Remarks	None					

Event name	Event Log Save Error			Event code	10230000 hex	
Meaning	Saving the event log failed.					
Source	PLC Function Module		Source details	None	Detection timing	At power ON or Controller reset
Error attributes	Level	Observation	Recovery	---	Log category	System
Effects	User program	Starts.	Operation	Not affected. However, part or all of the past event log cannot be read.		
System-defined variables	Variable		Data type		Name	
	None		---		---	
Cause and correction	Assumed cause		Correction		Prevention	
	A low battery voltage prevented retention of memory during a power interruption.		Replace the Battery.		Replace the battery periodically.	
Attached information	Attached information1: Error Details 0: Failure to save all categories of logs, 1: Failure to save system event log, 2: Failure to save access event log, 100: Failure to save user-defined event log					
Precautions/Remarks	None					

Event name	Trace Setting Transfer Failure			Event code	10260000 hex	
Meaning	The power supply was interrupted while transferring the trace settings.					
Source	PLC Function Module		Source details	None	Detection timing	At power ON or Controller reset
Error attributes	Level	Observation	Recovery	Cycle the power supply or reset the Controller.	Log category	System
Effects	User program	Continues.	Operation	Not affected.		
System-defined variables	Variable		Data type		Name	
	None		---		---	
Cause and correction	Assumed cause		Correction		Prevention	
	The power supply was interrupted while transferring the trace settings.		Transfer the trace settings again.		Do not interrupt the power supply while transferring the trace settings.	
Attached information	None					
Precautions/Remarks	All trace settings are initialized when this error occurs.					

Event name	Backup Failed to Start		Event code	10290000 hex		
Meaning	An error was detected in pre-execution checks for a backup operation.					
Source	PLC Function Module		Source details	None	Detection timing	When backup is specified by the user
Error attributes	Level	Observation	Recovery	---	Log category	System
Effects	User program	Continues.	Operation	Not affected.		
System-defined variables	Variable		Data type		Name	
	None		---		---	
Cause and correction	Assumed cause		Correction		Prevention	
	An SD Memory Card is not inserted.		Insert an SD Memory Card.		Insert an SD Memory Card.	
	The SD Memory Card type is not correct.		Replace the SD Memory Card with an SD or SDHC card.		Use an SD or SDHC card.	
	The format of the SD Memory Card is not correct.		Format the SD Memory Card with the Sysmac Studio.		Use a formatted SD Memory Card. Also, do not remove the SD Memory Card or turn OFF the power supply while the SD BUSY indicator is lit.	
	The SD Memory Card is write protected.		Remove write protection from the SD Memory Card.		Make sure that the SD Memory Card is not write protected.	
	The <i>Prohibiting backing up data to the SD Memory Card</i> parameter is set to prohibit backing up data to an SD Memory Card.		Change the setting of the <i>Prohibiting backing up data to the SD Memory Card</i> parameter to enable backing up data to an SD Memory Card.		Set the <i>Prohibiting backing up data to the SD Memory Card</i> parameter to enable backing up data to an SD Memory Card.	
	Another backup operation is in progress.		Wait for the other backup operation to end and then perform the backup operation again.		Do not attempt to perform other backup operation during a backup operation.	
	Synchronization, online editing, or the Clear All Memory operation is in progress.		Wait for the synchronization, online editing, or the Clear All Memory operation to end and then perform the backup operation again.		Do not attempt to perform a backup operation during a synchronization, online editing, or the Clear All Memory operation.	
	The backup was canceled by the user.		None		None	
The online connection with the Sysmac Studio was disconnected.		Check the cable connections. Go offline and then go back online and execute the backup again.		Check the cable to see if it is disconnected or broken. Make sure the cable is connected properly.		

Cause and correction	The SD Memory Card is damaged.	If none of the above causes applies, replace the SD Memory Card.	Do not remove the SD Memory Card or turn OFF the power supply while the SD BUSY indicator is lit. Replace the SD Memory Card periodically according to the write life of the SD Memory Card.
Attached information	<p>Attached information 1: Operation type</p> <p>0101 hex: Controller to SD Memory Card for switch operation on front of CPU Unit</p> <p>0102 hex: Controller to SD Memory Card for system variable operation</p> <p>0103 hex: Controller to SD Memory Card for Sysmac Studio operation</p> <p>0201 hex: Controller to computer</p> <p>Attached Information 2: Error Details</p> <p>0001 hex: An SD Memory Card is not inserted.</p> <p>0002 hex: The SD Memory Card is faulty, the format of the SD Memory Card is not correct, or the SD Memory Card is not the correct type of card.</p> <p>0003 hex: The SD Memory Card is write protected.</p> <p>0204 hex: SD Memory Card backup is prohibited.</p> <p>0205 hex: Another backup operation is in progress.</p> <p>0206 hex: Synchronization, online editing, or the Clear All Memory operation is in progress.</p> <p>0207 hex: A prohibited character is used in the directory name that is specified in the system-defined variable.</p> <p>0401 hex: The backup was canceled by the user.</p> <p>0501 hex: The online connection with the Sysmac Studio was disconnected.</p>		
Precautions/Remarks	None		

Event name	Backup Failed		Event code	102A0000 hex	
Meaning	The backup operation ended in an error.				
Source	PLC Function Module		Source details	None	Detection timing During backup operation
Error attributes	Level	Observation	Recovery	---	Log category System
Effects	User program	Continues.	Operation	Not affected.	
System-defined variables	Variable		Data type		Name
	None		---		---
Cause and correction	Assumed cause		Correction		Prevention
	The capacity of the SD Memory Card is insufficient.		Replace the SD Memory Card for one with sufficient available space.		Use an SD Memory Card that has sufficient available space.
	It was not possible to save the data that was specified for backup.		Perform the backup operation again when no data write operation to the CPU Unit is in progress.		Do not write to the CPU Unit when a backup operation is in progress.
	The SD Memory Card was removed during a backup operation.		Insert an SD Memory Card.		Insert an SD Memory Card.
	Failed to back up Unit or slave.		Refer to the corrections for the following events: CJ-series Unit Backup Failed (102D0000 hex) or EtherCAT Slave Backup Failed (102F0000 hex).		Refer to the prevention information for the following events: CJ-series Unit Backup Failed (102D0000 hex) or EtherCAT Slave Backup Failed (102F0000 hex).
	The backup was canceled by the user.		None		None
	Execution of the Save Cam Table instruction or changing the CPU Unit name is in progress.		Perform the operation after execution of the Save Cam Table instruction or changing the CPU Unit name is completed.		Do not perform a backup during execution of the Save Cam Table instruction or while changing the CPU Unit name.
	The online connection with the Sysmac Studio was disconnected.		Check the cable connections. Go offline and then go back online and execute the backup again.		Check the cable to see if it is disconnected or broken. Make sure the cable is connected properly.
	It was not possible to save the data that was specified for backup to the computer.		Increase the available space on the hard disk on the computer.		Make sure there is sufficient space available on the hard disk before you perform a backup.
	The SD Memory Card is damaged.		If none of the above causes applies, replace the SD Memory Card.		Do not remove the SD Memory Card or turn OFF the power supply while the SD BUSY indicator is lit. Replace the SD Memory Card periodically according to the write life of the SD Memory Card.
Attached information	<p>Attached information 1: Operation type</p> <p>0101 hex: Controller to SD Memory Card for switch operation on front of CPU Unit</p> <p>0102 hex: Controller to SD Memory Card for system variable operation</p> <p>0103 hex: Controller to SD Memory Card for Sysmac Studio operation</p> <p>0201 hex: Controller to computer</p> <p>Attached Information 2: Error Details</p> <p>0001 hex: The SD Memory Card was removed.</p> <p>0005 hex: There is not sufficient space available on the SD Memory Card.</p> <p>0206 hex: Execution of the Save Cam Table instruction or changing the CPU Unit name is in progress.</p> <p>0302 hex: Saving the backup data failed or the SD Memory Card is faulty.</p> <p>0304 hex: The Unit or slave could not be backed up.</p> <p>0401 hex: The backup was canceled by the user.</p> <p>0501 hex: The online connection with the Sysmac Studio was disconnected.</p> <p>0502 hex: It was not possible to save the data that was specified for backup to the computer.</p>				
Precautions/Remarks	None				

Event name	Restore Operation Failed to Start			Event code	102B0000 hex	
Meaning	An error was detected in pre-execution checks for a restore operation.					
Source	PLC Function Module		Source details	None	Detection timing	When restoring data is specified by the user
Error attributes	Level	Observation	Recovery	---	Log category	System
Effects	User program	---	Operation	Not affected.		
System-defined variables	Variable		Data type		Name	
	None		---		---	
Cause and correction	Assumed cause		Correction		Prevention	
	An SD Memory Card is not inserted.		Insert an SD Memory Card.		Insert an SD Memory Card.	
	The SD Memory Card type is not correct.		Replace the SD Memory Card with an SD or SDHC card.		Use an SD or SDHC card.	
	The format of the SD Memory Card is not correct.		Format the SD Memory Card with the Sysmac Studio and then place the backup files on it.		Use a formatted SD Memory Card and place the backup files on it. Also, do not remove the SD Memory Card or turn OFF the power supply while the SD BUSY indicator is lit.	
	There are no backup files on the SD Memory Card.		Place the backup files in the specified folder on the SD Memory Card.			
	Either the backup files on the SD Memory Card are corrupted or required data is not in the backup files on the SD Memory Card.		Create the backup files again.			
	The unit version of the CPU Unit to which to restore the files is older than the unit version of the backup files on the SD Memory Card.		Replace the CPU Unit with a CPU Unit that has a unit version that is the same as or newer than the unit version of the CPU Unit that was used to create the backup files. Or, specify backup files with the correct unit version for the CPU Unit.		Make sure that the unit version of the CPU Unit and the unit version of the backup files are compatible.	
	The model of the CPU Unit to which to restore the files is not the same as the model of the CPU Unit of the backup files on the SD Memory Card.		Replace the CPU Unit with a CPU Unit that has the same model as the CPU Unit that was used to create the backup files. Or, specify backup files with the correct model for the CPU Unit.		Make sure that the model of the CPU Unit is the same as the model of the CPU Unit that was used to create the backup files.	
	Recovery was executed for the SD Memory Card.		If there are no backup files or no restore command file in the specified folder on the SD Memory Card, place the files in the folder again.		None	
	The CPU Unit is write-protected.		If you use the restore function, select the <i>Do not use</i> Option for the <i>Write protection at startup</i> setting of the CPU Unit.		If you use the restore function, select the <i>Do not use</i> Option for the <i>Write protection at startup</i> setting of the CPU Unit.	
	The settings in the restore command file (RestoreCommand.ini) are not correct.		Make sure that the required files are set to "Yes" in the restore command file.		Make sure that the required files are set to "Yes" in the restore command file.	
	A backup operation is in progress.		Wait for the backup operation to end and then perform the restore operation again.		Do not attempt to perform a restore operation during a backup operation.	
	Synchronization, online editing, or the Clear All Memory operation is in progress.		Wait for the synchronization, online editing, or the Clear All Memory operation to end and then perform the restore operation again.		Do not attempt to perform a restore operation during a synchronization, online editing, or the Clear All Memory operation.	
The online connection with the Sysmac Studio was disconnected.		Check the cable connections. Go offline and then go back online and execute the backup again.		Check the cable to see if it is disconnected or broken. Make sure the cable is connected properly.		
Reading the data for restoration failed because the SD Memory Card is faulty or not formatted correctly.		Perform the same corrective measures as for when the format of the SD Memory Card is not correct or the SD Memory Card is damaged.		Perform the same preventive measures as for the following events: SD Memory Card Invalid Format or Faulty SD Memory Card.		

Cause and correction	The SD Memory Card is damaged.	If none of the above causes applies, replace the SD Memory Card.	Do not remove the SD Memory Card or turn OFF the power supply while the SD BUSY indicator is lit. Replace the SD Memory Card periodically according to the write life of the SD Memory Card.
	The database connection service version of the CPU Unit to which to restore the files is older than the database connection service version of the backup files on the SD Memory Card.	Replace the CPU Unit with a CPU Unit that has a database connection service version that is the same as or newer than the database connection service version of the CPU Unit that was used to create the backup files. Or, specify backup files with the correct database connection service version for the CPU Unit.	Make sure that the database connection service version of the CPU Unit and the database connection service version of the backup files are compatible.
	The robot version of the CPU Unit to which to restore the files is older than the robot version of the backup files on the SD Memory Card.	Replace the CPU Unit with a CPU Unit that has a robot version that is the same as or newer than the robot version of the CPU Unit that was used to create the backup files. Or, specify backup files with the correct robot version for the CPU Unit.	Make sure that the robot version of the CPU Unit and the robot version of the backup files are compatible.
Attached information	<p>Attached information 1: Operation type</p> <p>0101 hex: SD Memory Card to Controller for switch operation on front of CPU Unit</p> <p>0201 hex: Computer to Controller</p> <p>Attached Information 2: Error Details</p> <p>0001 hex: An SD Memory Card is not inserted.</p> <p>0002 hex: The SD Memory Card is faulty, the format of the SD Memory Card is not correct, or the SD Memory Card is not the correct type of card.</p> <p>0004 hex: Recovery was executed for the SD Memory Card.</p> <p>0102 hex: There are no backup files.</p> <p>0103 hex: The backup files are corrupted.</p> <p>0104 hex: The contents of the restore command file are not correct.</p> <p>0105 hex: The required transfer data is not in the backup file.</p> <p>0201 hex: The unit version of the CPU Unit is old.</p> <p>0202 hex: The model numbers of the CPU Unit are not the same.</p> <p>0203 hex: The CPU Unit is write-protected.</p> <p>0205 hex: Another backup operation is in progress.</p> <p>0206 hex: Synchronization, online editing, or the Clear All Memory operation is in progress.</p> <p>0211 hex: The database connection service or robot version of the CPU Unit is old.</p> <p>0301 hex: Reading data for restoration failed or the SD Memory Card is faulty.</p> <p>0501 hex: The online connection with the Sysmac Studio was disconnected.</p>		
Precautions/Remarks	None		

Event name	Restore Operation Failed			Event code	102C0000 hex	
Meaning	The restore operation ended in an error.					
Source	PLC Function Module		Source details	None	Detection timing	During restore operation
Error attributes	Level	Observation	Recovery	---	Log category	System
Effects	User program	---	Operation	Not affected.		
System-defined variables	Variable		Data type		Name	
	None		---		---	
Cause and correction	Assumed cause		Correction		Prevention	
	It was not possible to read the data to restore.		Format the SD Memory Card with the Sysmac Studio and then place the backup files on it.		Do not remove the SD Memory Card or turn OFF the power supply while the SD BUSY indicator is lit. Replace the SD Memory Card periodically according to the write life of the SD Memory Card.	
	The SD Memory Card was removed during a restore operation.		Insert an SD Memory Card that contains the backup files, and then execute the restore operation again.		Do not remove the SD Memory Card during the restore operation.	
	Failed to restore Unit or slave.		Refer to the corrections for the following events: CJ-series Unit Restore Operation Failed (102E0000 hex) or EtherCAT Slave Restore Operation Failed (10300000 hex).		Refer to the prevention information for the following events: CJ-series Unit Restore Operation Failed (102E0000 hex) or EtherCAT Slave Restore Operation Failed (10300000 hex).	
	The SD Memory Card is damaged.		If none of the above causes applies, replace the SD Memory Card.		Do not remove the SD Memory Card or turn OFF the power supply while the SD BUSY indicator is lit. Replace the SD Memory Card periodically according to the write life of the SD Memory Card.	
Attached information	<p>Attached information 1: Operation type</p> <p>0101 hex: SD Memory Card to Controller for switch operation on front of CPU Unit</p> <p>0201 hex: Computer to Controller</p> <p>Attached Information 2: Error Details</p> <p>0001 hex: The SD Memory Card was removed.</p> <p>0102 hex: There are no backup files.</p> <p>0103 hex: The backup files are corrupted.</p> <p>0301 hex: Reading data for restoration failed or the SD Memory Card is faulty.</p> <p>0303 hex: The Unit or slave could not be restored.</p>					
Precautions/Remarks	None					

Event name	PLC System Information			Event code	40140000 hex	
Meaning	This event provides internal information from the PLC Function Module.					
Source	PLC Function Module		Source details	None	Detection timing	Continuously
Error attributes	Level	Observation	Recovery	---	Log category	System
Effects	User program	Continues.	Operation	Operation is not affected.		
System-defined variables	Variable		Data type		Name	
	None		---		---	
Cause and correction	Assumed cause		Correction		Prevention	
	This event provides internal information from the PLC Function Module. It is recorded to provide additional information for another event.		---		---	
Attached information	Attached information 1: System information Attached Information 2: System information Attached information 3: System information Attached information 4: System information					
Precautions/Remarks	None					

Event name	Safe Mode			Event code	40170000 hex	
Meaning	The Controller started in Safe Mode.					
Source	PLC Function Module		Source details	None	Detection timing	At power ON or Controller reset
Error attributes	Level	Observation	Recovery	---	Log category	System
Effects	User program	Stops.	Operation	---		
System-defined variables	Variable		Data type		Name	
	None		---		---	
Cause and correction	Assumed cause		Correction		Prevention	
	The power supply was turned ON to the Controller when Safe Mode was set on the DIP switch on the CPU Unit.		---		---	
Attached information	None					
Precautions/Remarks	If the Controller is started when the CPU Unit is in Safe Mode, the CPU Unit will start in PROGRAM mode even if the startup mode is set to RUN mode.					

Event name	NX Message Communications Error			Event code	80230000 hex	
Meaning	An error has occurred in message communications.					
Source	PLC Function Module EtherCAT Master Function Module EtherNet/IP Function Module		Source details	None	Detection timing	During NX message communications
Error attributes	Level	Observation	Recovery	---	Log category	System
Effects	User program	Continues.	Operation	---		
System-defined variables	Variable		Data type		Name	
	None		---		---	
Cause and correction	Assumed cause		Correction		Prevention	
	The communications cable is broken.		Check the communications cable and replace it if it is broken.		Check the communications cable to see if it is operating properly.	
	The communications cable connector is disconnected.		Reconnect the connector and make sure it is mated correctly.		Make sure the communications cable is connected properly.	
	The NX message communications load is high.		Reduce the number of times that instructions are used to send NX messages. Or, increase the value of the <i>TimeOut</i> input variable to the instruction. If more than one copy of the Sysmac Studio is connected, reduce the frequency of simultaneous operations.		Reduce the number of times that instructions are used to send NX messages. Or, increase the value of the <i>TimeOut</i> input variable to the instruction. If more than one copy of the Sysmac Studio is connected, reduce the frequency of simultaneous operations.	
Attached information	Attached information 1: System information Attached Information 2: Type of communications 0: NX bus 1: EtherCAT 65,535: Unit internal communications (routing)					
Precautions/Remarks	None					

Event name	PLC System Information			Event code	40150000 hex	
Meaning	This event provides internal information from the PLC Function Module.					
Source	PLC Function Module		Source details	None	Detection timing	Continuously
Error attributes	Level	Information	Recovery	---	Log category	System
Effects	User program	Continues.	Operation	Operation is not affected.		
System-defined variables	Variable		Data type		Name	
	None		---		---	
Cause and correction	Assumed cause		Correction		Prevention	
	This event provides internal information from the PLC Function Module. It is recorded to provide additional information for another event.		---		---	
Attached information	Attached information 1: System information Attached Information 2: System information Attached information 3: System information Attached information 4: System information					
Precautions/Remarks	None					

Event name	PLC System Information			Event code	44430000 hex	
Meaning	This event provides internal information from the PLC Function Module.					
Source	PLC Function Module		Source details	None	Detection timing	Continuously
Error attributes	Level	Information	Recovery	---	Log category	System
Effects	User program	Continues.	Operation	Operation is not affected.		
System-defined variables	Variable		Data type		Name	
	None		---		---	
Cause and correction	Assumed cause		Correction		Prevention	
	This event provides internal information from the PLC Function Module. It is recorded to provide additional information for another event.		---		---	
Attached information	Attached information 1: System information Attached information 2: System information Attached information 3: System information Attached information 4: System information					
Precautions/Remarks	None					

Event name	Clock Changed			Event code	90010000 hex	
Meaning	The clock time was changed.					
Source	PLC Function Module		Source details	None	Detection timing	Commands from user
Error attributes	Level	Information	Recovery	---	Log category	Access
Effects	User program	Continues.	Operation	Not affected.		
System-defined variables	Variable		Data type		Name	
	_CurrentTime		DATE_AND_TIME		System Time	
Cause and correction	Assumed cause		Correction		Prevention	
	The clock time was changed.		---		---	
Attached information	Attached information 1: Time before change					
Precautions/Remarks	Clock changes by the Set Time instruction (SetTime) are not recorded in the event log. The time stamp for this event will be for the time after the change.					

Event name	Time Zone Changed			Event code	90020000 hex	
Meaning	The time zone was changed.					
Source	PLC Function Module		Source details	None	Detection timing	When downloading
Error attributes	Level	Information	Recovery	---	Log category	Access
Effects	User program	Continues.	Operation	Not affected.		
System-defined variables	Variable		Data type		Name	
	_CurrentTime		DATE_AND_TIME		System Time	
Cause and correction	Assumed cause		Correction		Prevention	
	The time zone was changed.		---		---	
Attached information	None					
Precautions/Remarks	None					

Event name	User Program/Controller Configurations and Setup Downloaded			Event code	90050000 hex	
Meaning	The user program and the Controller configurations and setup were downloaded.					
Source	PLC Function Module		Source details	None	Detection timing	During user program/Controller configurations and setup download
Error attributes	Level	Information	Recovery	---	Log category	Access
Effects	User program	Continues.	Operation	Operation starts according to the user program and the Controller setup data that were downloaded.		
System-defined variables	Variable		Data type		Name	
	None		---		---	
Cause and correction	Assumed cause		Correction		Prevention	
	The user program and the Controller configurations and setup were downloaded.		---		---	
Attached information	<p>Attached Information 1: Connection method 1: Direct USB connection 2: Direct Ethernet connection 3: Remote USB connection or Ethernet hub connection</p> <p>Attached Information 2: Connecting IP address, Connection through proxy: Proxy IP address (When attached information 1 is 2 or 3)</p>					
Precautions/Remarks	None					

Event name	Online Edits Transferred			Event code	90070000 hex	
Meaning	The user program was edited online.					
Source	PLC Function Module		Source details	None	Detection timing	When transferring online edits is started
Error attributes	Level	Information	Recovery	---	Log category	Access
Effects	User program	Continues.	Operation	Operation is performed according to the changed user program.		
System-defined variables	Variable		Data type		Name	
	None		---		---	
Cause and correction	Assumed cause		Correction		Prevention	
	The user program was edited online and the edits were transferred to the Controller.		---		---	
Attached information	<p>Attached Information 1: Connection method 1: Direct USB connection 2: Direct Ethernet connection 3: Remote USB connection or Ethernet hub connection</p> <p>Attached Information 2: Connecting IP address, Connection through proxy: Proxy IP address (When attached information 1 is 2 or 3)</p>					
Precautions/Remarks	None					

Event name	Variable Changed to TRUE with Forced Refreshing			Event code	90080000 hex	
Meaning	Changing a variable to TRUE with forced refreshing was specified.					
Source	PLC Function Module		Source details	None	Detection timing	Commands from user
Error attributes	Level	Information	Recovery	---	Log category	Access
Effects	User program	Continues.	Operation	Operation is performed according to the forced refreshing values.		
System-defined variables	Variable		Data type		Name	
	None		---		---	
Cause and correction	Assumed cause		Correction		Prevention	
	Changing a variable to TRUE with forced refreshing was specified by the user.		---		---	
Attached information	None					
Precautions/Remarks	None					

Event name	Variable Changed to FALSE with Forced Refreshing			Event code	90090000 hex	
Meaning	Changing a variable to FALSE with forced refreshing was specified.					
Source	PLC Function Module		Source details	None	Detection timing	Commands from user
Error attributes	Level	Information	Recovery	---	Log category	Access
Effects	User program	Continues.	Operation	Operation is performed according to the forced refreshing values.		
System-defined variables	Variable		Data type		Name	
	None		---		---	
Cause and correction	Assumed cause		Correction		Prevention	
	Changing a variable to FALSE with forced refreshing was specified by the user.		---		---	
Attached information	None					
Precautions/Remarks	None					

Event name	All Forced Refreshing Cleared			Event code	900A0000 hex	
Meaning	Clearing all forced refreshing values was specified.					
Source	PLC Function Module		Source details	None	Detection timing	Commands from user
Error attributes	Level	Information	Recovery	---	Log category	Access
Effects	User program	Continues.	Operation	Forced refreshing values are all cleared and operation is performed according to the user program.		
System-defined variables	Variable		Data type		Name	
	None		---		---	
Cause and correction	Assumed cause		Correction		Prevention	
	Clearing all forced refreshing values was specified by the user.		---		---	
Attached information	None					
Precautions/Remarks	None					

Event name	Memory All Cleared			Event code	900B0000 hex	
Meaning	All of memory was cleared.					
Source	PLC Function Module		Source details	None	Detection timing	Commands from user
Error attributes	Level	Information	Recovery	---	Log category	Access
Effects	User program	---	Operation	Operation returns to the factory state.		
System-defined variables	Variable		Data type		Name	
	None		---		---	
Cause and correction	Assumed cause		Correction		Prevention	
	A user with Administrator rights cleared all of the memory.		---		---	
Attached information	None					
Precautions/Remarks	None					

Event name	Event Log Cleared			Event code	900C0000 hex	
Meaning	The event log was cleared.					
Source	PLC Function Module		Source details	None	Detection timing	Commands from user
Error attributes	Level	Information	Recovery	---	Log category	Access
Effects	User program	Continues.	Operation	Not affected.		
System-defined variables	Variable		Data type		Name	
	None		---		---	
Cause and correction	Assumed cause		Correction		Prevention	
	The event log was cleared by the user.		---		---	
Attached information	Attached information 1: Cleared events 0: All log categories were cleared 1: The system event log was cleared. 2: The access event log was cleared. 100: The user-defined event log was cleared.					
Precautions/Remarks	None					

Event name	Automatic Transfer Completed			Event code	900F0000 hex	
Meaning	The automatic transfer was completed.					
Source	PLC Function Module		Source details	None	Detection timing	At power ON
Error attributes	Level	Information	Recovery	---	Log category	System
Effects	User program	Continues.	Operation	Operation starts according to the Controller Configurations and Setup data that was automatically transferred.		
System-defined variables	Variable		Data type		Name	
	None		---		---	
Cause and correction	Assumed cause		Correction		Prevention	
	The automatic transfer was completed.		---		---	
Attached information	None					
Precautions/Remarks	None					

Event name	Power Turned ON			Event code	90110000 hex	
Meaning	The power supply was turned ON.					
Source	PLC Function Module		Source details	None	Detection timing	At power ON
Error attributes	Level	Information	Recovery	---	Log category	System
Effects	User program	----	Operation	Operation starts.		
System-defined variables	Variable		Data type		Name	
	None		---		---	
Cause and correction	Assumed cause		Correction		Prevention	
	The power supply was turned ON.		---		---	
Attached information	None					
Precautions/Remarks	None					

Event name	Power Interrupted			Event code	90120000 hex	
Meaning	The power supply was interrupted.					
Source	PLC Function Module		Source details	None	Detection timing	At power interruption
Error attributes	Level	Information	Recovery	---	Log category	System
Effects	User program	Stops.	Operation	All operations stops.		
System-defined variables	Variable		Data type		Name	
	None		---		---	
Cause and correction	Assumed cause		Correction		Prevention	
	The power supply was interrupted.		---		---	
Attached information	None					
Precautions/Remarks	None					

Event name	Operation Started			Event code	90130000 hex	
Meaning	Operation was started.					
Source	PLC Function Module		Source details	None	Detection timing	When changing to RUN mode
Error attributes	Level	Information	Recovery	---	Log category	System
Effects	User program	Starts.	Operation	User program execution starts.		
System-defined variables	Variable		Data type		Name	
	None		---		---	
Cause and correction	Assumed cause		Correction		Prevention	
	A command to start operation was received.		---		---	
Attached information	None					
Precautions/Remarks	None					

Event name	Operation Stopped			Event code	90140000 hex	
Meaning	Operation was stopped.					
Source	PLC Function Module		Source details	None	Detection timing	When changing to PROGRAM mode
Error attributes	Level	Information	Recovery	---	Log category	System
Effects	User program	Stops.	Operation	User program execution stops.		
System-defined variables	Variable		Data type		Name	
	None		---		---	
Cause and correction	Assumed cause		Correction		Prevention	
	A command to stop operation was received.		---		---	
Attached information	None					
Precautions/Remarks	None					

Event name	Reset Executed			Event code	90150000 hex	
Meaning	A reset was executed.					
Source	PLC Function Module		Source details	None	Detection timing	Commands from user
Error attributes	Level	Information	Recovery	---	Log category	Access
Effects	User program	---	Operation	Operation is started after a reset is executed.		
System-defined variables	Variable		Data type		Name	
	None		---		---	
Cause and correction	Assumed cause		Correction		Prevention	
	A reset command was received.		---		---	
Attached information	None					
Precautions/Remarks	None					

Event name	User Program Execution ID Write			Event code	90160000 hex	
Meaning	The user program execution ID was set or changed in the CPU Unit.					
Source	PLC Function Module		Source details	None	Detection timing	When downloading
Error attributes	Level	Information	Recovery	---	Log category	Access
Effects	User program	Continues.	Operation	Not affected.		
System-defined variables	Variable		Data type		Name	
	None		---		---	
Cause and correction	Assumed cause		Correction		Prevention	
	A user with Administrator rights changed the user program execution ID that is set in the CPU Unit.		---		---	
Attached information	None					
Precautions/Remarks	None					

Event name	All Controller Errors Cleared			Event code	90180000 hex	
Meaning	All current errors were cleared.					
Source	PLC Function Module		Source details	None	Detection timing	Commands from user
Error attributes	Level	Information	Recovery	---	Log category	Access
Effects	User program	Continues.	Operation	Clearing all errors for which the causes have been removed.		
System-defined variables	Variable		Data type		Name	
	None		---		---	
Cause and correction	Assumed cause		Correction		Prevention	
	The user cleared all current errors.		---		---	
Attached information	None					
Precautions/Remarks	None					

Event name	Forced Refreshing Cleared			Event code	90190000 hex	
Meaning	Clearing a forced refreshing value was specified.					
Source	PLC Function Module		Source details	None	Detection timing	Commands from user
Error attributes	Level	Information	Recovery	---	Log category	Access
Effects	User program	Continues.	Operation	Forced refreshing values are cleared and operation is performed according to the user program.		
System-defined variables	Variable		Data type		Name	
	None		---		---	
Cause and correction	Assumed cause		Correction		Prevention	
	Clearing a forced refreshing value was specified by the user.		---		---	
Attached information	None					
Precautions/Remarks	None					

Event name	Backup Started			Event code	901A0000 hex	
Meaning	A backup operation was started.					
Source	PLC Function Module		Source details	None	Detection timing	At start of backup operation
Error attributes	Level	Information	Recovery	---	Log category	System
Effects	User program	Continues.	Operation	Not affected.		
System-defined variables	Variable		Data type		Name	
	None		---		---	
Cause and correction	Assumed cause		Correction		Prevention	
	A backup operation was started.		---		---	
Attached information	Attached information 1: Operation type 0101 hex: Controller to SD Memory Card for switch operation on front of CPU Unit 0102 hex: Controller to SD Memory Card for system variable operation 0103 hex: Controller to SD Memory Card for Sysmac Studio operation 0201 hex: Controller to computer					
Precautions/Remarks	None					

Event name	Backup Completed			Event code	901B0000 hex	
Meaning	The backup operation ended normally.					
Source	PLC Function Module		Source details	None	Detection timing	At end of normal backup operation
Error attributes	Level	Information	Recovery	---	Log category	System
Effects	User program	Continues.	Operation	Not affected.		
System-defined variables	Variable		Data type		Name	
	None		---		---	
Cause and correction	Assumed cause		Correction		Prevention	
	The backup operation ended normally.		---		---	
Attached information	Attached information 1: Operation type 0101 hex: Controller to SD Memory Card for switch operation on front of CPU Unit 0102 hex: Controller to SD Memory Card for system variable operation 0103 hex: Controller to SD Memory Card for Sysmac Studio operation 0201 hex: Controller to computer					
Precautions/Remarks	None					

Event name	Restore Operation Started			Event code	901C0000 hex	
Meaning	A restore operation started.					
Source	PLC Function Module		Source details	None	Detection timing	At start of restore operation
Error attributes	Level	Information	Recovery	---	Log category	System
Effects	User program	---	Operation	Not affected.		
System-defined variables	Variable		Data type		Name	
	None		---		---	
Cause and correction	Assumed cause		Correction		Prevention	
	A restore operation started.		---		---	
Attached information	Attached information 1: Operation type 0101 hex: SD Memory Card to Controller for switch operation on front of CPU Unit 0201 hex: Computer to Controller					
Precautions/Remarks	None					

Event name	Restore Operation Completed			Event code	901D0000 hex	
Meaning	The restore operation ended normally.					
Source	PLC Function Module		Source details	None	Detection timing	At end of normal restore operation
Error attributes	Level	Information	Recovery	---	Log category	System
Effects	User program	---	Operation	Operation does not start after the completion of a restore operation. To start operation according to the restored user program and settings, turn OFF the power supply to the Controller, turn OFF all pins on the DIP switch on the CPU Unit, and then turn ON the power supply again.		
System-defined variables	Variable		Data type		Name	
	None		---		---	
Cause and correction	Assumed cause		Correction		Prevention	
	The restore operation ended normally.		---		---	
Attached information	Attached information 1: Operation type 0101 hex: SD Memory Card to Controller for switch operation on front of CPU Unit 0201 hex: Computer to Controller					
Precautions/Remarks	None					

6

Inspection and Maintenance

This section describes the required inspections and maintenance. It also describes the service lives and replacement procedures for the Battery and Power Supply Units.

6-1	Cleaning and Maintenance	6-2
6-1-1	Cleaning	6-2
6-1-2	Periodic Inspections	6-2
6-1-3	Unit Replacement Precautions	6-5
6-2	Replacing the Battery	6-6
6-2-1	Battery Replacement	6-6
6-2-2	Operation without a Battery	6-10
6-3	Replacing the Fan Unit	6-11
6-3-1	Purpose of Attaching the Fan Unit	6-11
6-3-2	Fan Unit Replacement Period	6-11
6-3-3	Fan Unit Used for Replacement	6-11
6-3-4	Procedure of Fan Unit Replacement	6-12

6-1 Cleaning and Maintenance

This section describes daily maintenance and the cleaning and inspection methods.

Inspect the NX-series CPU Unit daily or periodically in order to keep it in optimal operating condition.

6-1-1 Cleaning

Perform the following cleaning procedures periodically to ensure the NX-series CPU Unit is maintained in the best operating condition. Always turn OFF the power supply to the Controller before performing the cleaning procedures.

- Wipe off the dust or dirt on the front, top or bottom of the Unit over with a dry, soft cloth when doing daily cleaning.
- If dust or dirt remains even after wiping with a soft, dry cloth, wipe over with a cloth that has been wet with a sufficiently diluted detergent (2%) and wrung dry.
- Perform the following procedure when you clean a Fan Unit used in a dusty environment.
 - a) Remove the Fan Unit, and clean it with a dry, soft cloth. Do not blow the fan blade strongly with tools such as a gas duster. Doing so may cause a Fan Unit failure.
 - b) Remove the dust on the heatsink inside the CPU Unit with tools such as an antistatic gas duster. Do not touch the inside of the CPU Unit.
- A smudge may remain on the Unit from gum, vinyl, or tape that was left on for a long time. Remove the smudge when cleaning.



Precautions for Safe Use

- Always turn OFF the power supply to the Controller before attaching or removing the Fan Unit. The Power Supply Unit may continue to supply power to the rest of the Controller for a few seconds after the power supply turns OFF. The PWR indicator is lit during this time. Confirm that the PWR indicator is not lit before you perform any of the above.
- Do not touch the heatsink inside the CPU Unit immediately after turning OFF the power supply. Doing so may result in burn injury.



Precautions for Correct Use

- Never use volatile solvents, such as paint thinner, benzene, or chemical wipes.
- Do not touch the connectors.

6-1-2 Periodic Inspections

Although the major components in NX-series Controllers have an extremely long life time, they can deteriorate under improper environmental conditions. Periodic inspections are thus required to ensure that the required conditions are being kept.

Inspection is recommended at least once every six months to a year, but more frequent inspections may be necessary depending on the severe environments.

Take immediate steps to correct the situation if any of the conditions in the following table are not met.

Periodic Inspection Items

No.	Inspection item	Inspection details	Criteria	Correction
1	External power supply	Check for voltage fluctuations at the power supply terminals.	The voltage must be within the allowable voltage fluctuation range.	Use a voltage tester to check the power supply at the terminals. Take necessary steps to bring voltage of the supplied power to within the allowable voltage fluctuation range.
2	I/O power supply	Check for voltage fluctuations at the I/O terminals.	Voltages must be within specifications for each Unit.	Use a voltage tester to check the I/O power supply at the terminals. Take necessary steps to bring voltage fluctuations within limits.
3	Ambient environment	Check the ambient temperature. (Inside the control panel if the Controller is in a control panel.)	0 to 55°C	Use a thermometer to check the temperature and ensure that the ambient temperature remains within the allowed range of 0 to 55°C.
		Check the ambient humidity. (Inside the control panel if the Controller is in a control panel.)	Relative humidity must be 10% to 95% with no condensation.	Use a hygrometer to check the humidity and ensure that the ambient operating humidity remains between 10% and 95%. Make sure that condensation does not occur due to rapid changes in temperature.
		Check that the Controller is not in direct sunlight.	Not in direct sunlight	Protect the Controller if necessary.
		Check for accumulation of dirt, dust, salt, metal powder, etc.	No accumulation	Clean and protect the Controller if necessary.
		Check for water, oil, or chemical sprays hitting the Controller.	No spray	Clean and protect the Controller if necessary.
		Check for corrosive or flammable gases in the area of the Controller.	No corrosive or flammable gases	Check by smell or use a gas sensor.
		Check the level of vibration or shock.	Vibration resistance and shock resistance must be within specifications.	Install cushioning or shock absorbing equipment if necessary.
		Check for noise sources near the Controller.	No significant noise sources	Either separate the Controller and noise source or protect the Controller.
4	Installation and wiring	Check that each Unit is connected and locked to the next Unit securely.	No looseness	Press the connectors together completely and lock them with the sliders.
		Check that cable connectors are fully inserted and locked.	No looseness	Correct any improperly installed connectors.
		Check for loose screws in external wiring.	No looseness	Tighten loose screws with a Phillips-head screwdriver.
		Check crimp connectors in external wiring.	Adequate spacing between connectors	Check visually and adjust if necessary.
		Check for damaged external wiring cables.	No visible damage	Check visually and replace cables if necessary.

No.	Inspection item	Inspection details	Criteria	Correction
5	User-serviceable parts	Battery Set CJ1W-BAT01 Check whether the battery has reached its service life.	Service life expectancy is 5 years at 25°C. Depending on model and ambient temperature.	Replace the battery when its service life has passed even if a battery error has not occurred. (Battery life depends upon the model, and ambient conditions.) Refer to <i>6-2-1 Battery Replacement</i> on page 6-6 for the service life of individual model.
		Check whether the NX-FAN01 Fan Unit has reached its service life, or whether it is rotated during power supply.	Service life expectancy is 10 years at 55 °C.	Replace the Fan Unit when its service life has passed even if the fan speed has not decreased. Refer to <i>6-3-3 Fan Unit Used for Replacement</i> on page 6-11 for the service life, and <i>6-3-4 Procedure of Fan Unit Replacement</i> on page 6-12 for how to replace the Fan Unit.

Tools Required for Inspections

● Required Tools

- Flat-blade screwdriver
- Phillips screwdriver
- Voltage tester or digital voltmeter
- Industrial alcohol and pure cotton cloth
- Antistatic gas duster

● Tools Required Occasionally

- Oscilloscope
- Thermometer and hygrometer

6-1-3 Unit Replacement Precautions

Check the following after replacing any faulty Unit.

- Do not replace a Unit until the power is turned OFF.
- Check the new Unit to make sure that there are no errors.
- If you return a faulty Unit for repair, describe the problem in as much detail as possible, enclose this description with the Unit before returning it.
- For poor contact, take a clean cotton cloth, soak the cloth in industrial alcohol, and carefully wipe the contacts clean. Be sure to remove any lint prior to remounting the Unit.



Precautions for Correct Use

- Make sure that the required data, including the user program, settings and variables is transferred to a CPU Unit that was replaced and to externally connected devices before restarting operation. Be sure to include the tag data link settings and routing tables, which are stored in the CPU Unit.
 - The *absolute encoder home offsets* are backed up with a Battery in the CPU Unit as absolute encoder information. When you change the combination of the CPU Unit and Servomotor, e.g., when you add or replace a Servomotor, define the absolute encoder home again.
 - If you replace a slave or Unit, refer to operation manual for the slave or Unit for information on the data required for individual slaves or Units and redo the necessary settings.
-

6-2 Replacing the Battery

The Battery in the NX-series CPU Unit must be replaced periodically as preventative maintenance. (The Battery is a backup power supply for the CPU Unit's internal clock and the variables that are retained during power interruptions.) This section describes how to replace the Battery.

6-2-1 Battery Replacement

Purpose of the Battery

The Battery maintains the CPU Unit internal clock and the variables retained during power interruptions while the main power supply is OFF.

If the Battery is not installed or Battery voltage drops too low, the internal clock will stop and the variables that are retained for power interruptions will be lost when the main power supply goes OFF.

Battery Service Life and Replacement Period

The service life of a Battery is five years, which varies depending on the CPU Unit model, ambient temperature, and power ON time rate.

Make a plan to replace the Battery so that the service life of the Battery will not exceed the minimum lifetime under the normal product usage condition.

The Battery service life when power ON time rate is 0% (i.e., power OFF)

Unit model number	Approx. minimum lifetime [month] ^{*1}			Reference life-time [month] ^{*2}
	25°C	40°C	55°C	25°C
NX701-□□□□	31	17	10	60

*1. The minimum lifetime we warrant is based on the calculation with the worst case values within the specifications for the parts used in the product.

*2. The lifetime is based on the calculation with test data of the product. This value is used only for reference because deviation for individual model is not considered.

Battery service life (minimum lifetime) of NX701-□□□□ in relation to power ON time rate and ambient temperature

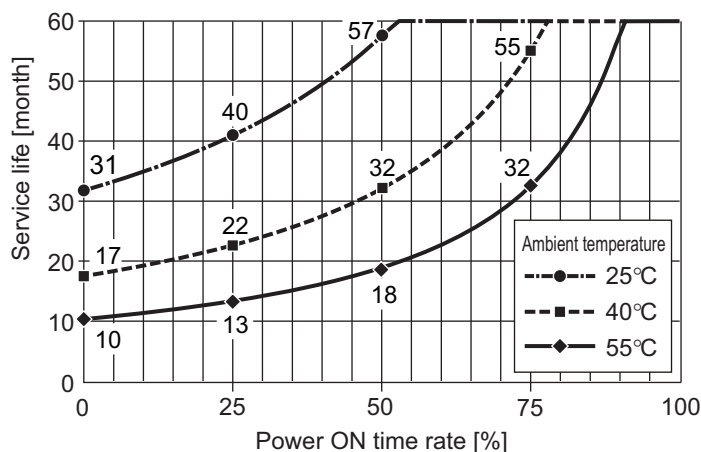

Unit model number	Power ON time rate	Battery service life (minimum lifetime) [month]		
		25°C	40°C	55°C
NX701-□□□□	0%	31	17	10
	25%	40	22	13
	50%	57	32	18
	75%	60	55	32
	100%	60	60	60



Additional Information

The Battery installed at the time of purchase is only for monitoring purpose to test the battery backup function. The Battery is exhausted depending on the period from factory checking to actual operation, thus it may not satisfy specified battery lifetime.

Low Battery Indicators

If the Controller Setup has been set to detect a low-battery error, the ERROR indicator on the front of the CPU Unit will flash when the battery is nearly discharged.

If the ERROR indicator flashes, connect the Sysmac Studio, and then check the CPU Unit's Battery connection if the Sysmac Studio shows a *Low Battery Voltage*, *Battery-backup Memory Check Error*, or *Clock Oscillator Stopped* event. If the Battery is properly connected, replace the Battery with a new one as soon as possible.

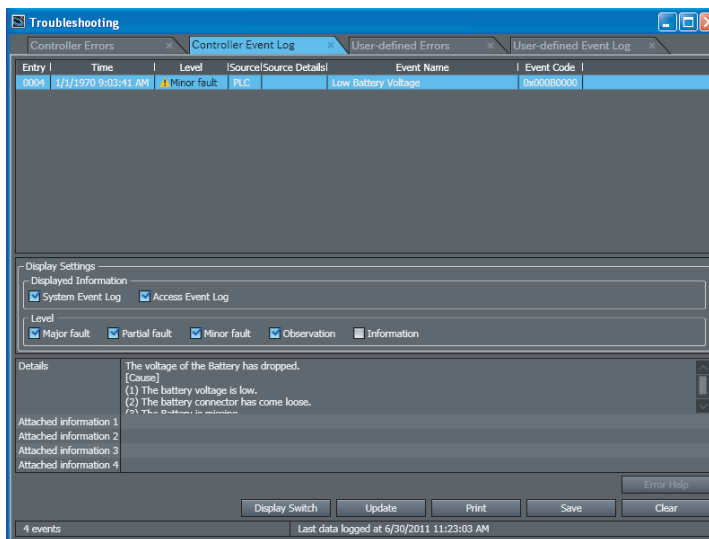

Once a low-battery error has been detected, it will take 5 days (at an ambient temperature of 25°C) before the battery fails if power has been supplied at least once a day.

Clock data and variables that are retained during power interruptions can be retained by ensuring that the CPU Unit power is not turned OFF until the Battery has been replaced.



Precautions for Correct Use

The Battery will lose its charge faster at high ambient temperatures.

● Replacement Battery

Use the Battery CJ1W-BAT01 for replacement.



Precautions for Correct Use

Be sure to install a replacement Battery within two years of the production date shown on the Battery label.

Production Date



Manufactured in March 2015.

Replacement Procedure

Use the following procedure to replace the battery.



Precautions for Safe Use

We recommend replacing the battery with the power OFF to prevent the CPU Unit's sensitive internal components from being damaged by static electricity. The battery can be replaced without turning OFF the power supply. To do so, always touch a grounded piece of metal to discharge static electricity from your body before starting the procedure.

After you replace the Battery, connect the Sysmac Studio and clear the *Low Battery Voltage* event.



Additional Information

UL standards require that batteries be replaced by experienced technicians. Always place an experienced technician in charge of battery replacement.

- 1** Turn OFF the power supply to the Controller.

If the CPU Unit has not been ON, turn it ON for at least five minutes and then turn it OFF.



Additional Information

If power is not turned ON for at least five minutes before replacing the Battery, the capacitor that backs up memory when the battery is removed will not be fully charged and memory may be lost before the new battery is inserted.

2 Replace the battery.

(1) Pull the upper side of the right CPU Unit cover forward and remove from the Unit.

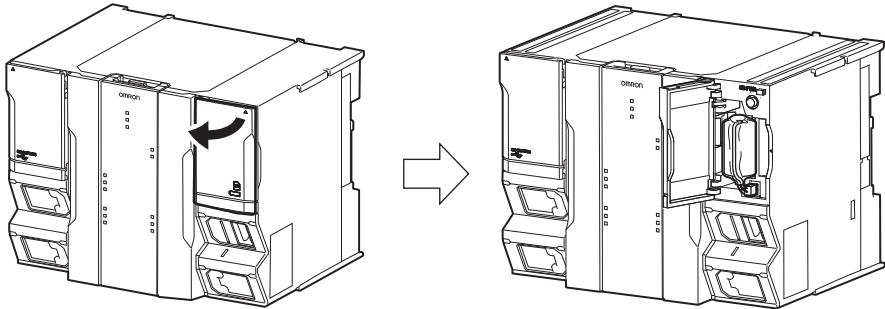

(2) Draw out the battery from the battery connector and replace a new battery.

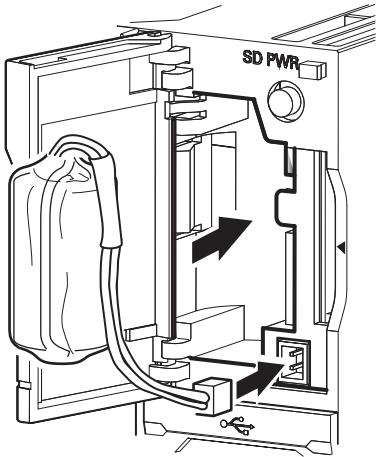

When placing the new battery, hanging battery wires on the protrusion for placing wires will allow for compact storage of wires.

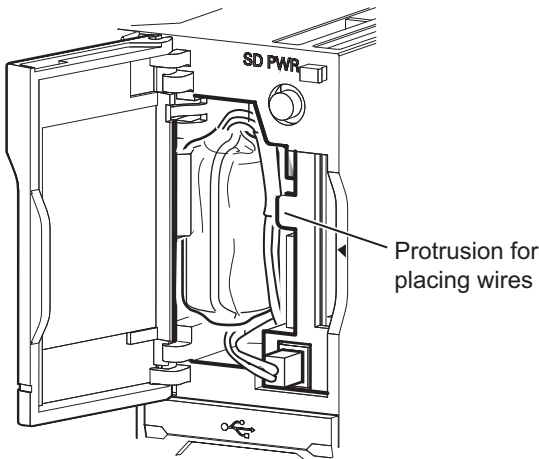

**Precautions for Safe Use**

- Before you replace the Battery, you must first supply power to the Controller for at least 5 minutes, and then you must complete this procedure within 5 minutes at 25°C after turning OFF the power to the CPU Unit to ensure memory backup.
- Never short-circuit the battery terminals; never charge the battery; never disassemble the battery; and never heat or incinerate the battery. Doing any of these may cause the battery to leak, heat, ignite, or rupture.
- Never use a battery that has been dropped on the floor or otherwise subject to shock. It may leak.
- Turn ON the power after replacing the Battery for a CPU Unit that has been unused for a long time. Leaving the CPU Unit unused again without turning ON the power even once after the battery is replaced may result in a shorter battery life.

**Additional Information**

The *Low Battery Voltage* event is cleared automatically the next time the Controller is turned ON after replacing the Battery.

6-2-2 Operation without a Battery

The NX-series CPU Units do not support a battery-free operation function such as CJ-series CPU Units. If a Battery is not connected or the Battery voltage is too low, the following operation occurs.

- A *Low Battery Voltage*, *Battery-backup Memory Check Error*, and *Clock Oscillator Stopped* events are detected.
- The *_RetainFail* (Power Retention Failure Flag) system-defined variable will be TRUE.

● Retaining or Not Retaining Data in the CPU Unit

Data in the CPU Unit will be retained or not retained as described in the following table according to whether there is a Battery.

Type of data		Power turned ON	
		Battery	No Battery
User program		Values before power interruption will be retained by the built-in non-volatile memory.	
Controller Configurations and Setup		Values before power interruption will be retained.	
Event log		Values before power interruption will be retained.	Values before power interruption will not be retained.
Clock data		Correct values	Illegal values
Values of variables	No Retain attribute	Initial values ^{*1}	Initial values ^{*1}
	Retain attribute	Values before power interruption will be retained.	Initial values ^{*1}

*1. If the initial value setting is blank, the initial value for the data type is used. For example, the initial value of BOOL data is FALSE and the initial value of integer data is 0. Refer to the *NJ/NX-series CPU Unit Software User's Manual* (Cat. No. W501) for details on the initial values.

6-3 Replacing the Fan Unit

This section describes how to replace the Fan Unit, a part of the NX7-series CPU Unit that allows replacement as preventive maintenance.

6-3-1 Purpose of Attaching the Fan Unit

A CPU that is incorporated in an NX7-series CPU Unit requires forced cooling to maintain its performance. A Fan Unit is used to cool the CPU.

If the Fan Unit is not mounted, or if rotation of the fan stops or the rotation speed decreases due to a failure or other causes, a *Slow Fan* error occurs in the Controller. If you continue the operation without taking measures, a *CPU Unit Overheat* error (a minor fault level Controller error) or a *CPU Unit Overheat* (Operation Stopped) error may occur. The latter will stop operation of the Controller.

6-3-2 Fan Unit Replacement Period

The Fan Unit has a high resistance to wear and a long service life that corresponds to the life of an NX7-series CPU Unit. However, an accidental failure may be caused by entry of foreign particles or other factors.

The NX7-series CPU Units employ a replaceable Fan Unit that allows preventative maintenance.

You need to replace the Fan Unit if the Fan Unit stops or a *Slow Fan* error occurs and operation is not recovered after you remove the obstacle from the Fan Unit.

When you replace the Fan Unit, stop the operation and turn OFF the power supply to the Controller.

6-3-3 Fan Unit Used for Replacement

Use an NX-FAN01 Fan Unit.

The service life of a Fan Unit is 10 years at the ambient temperature of 55°C, and the storage limitation for a Fan Unit that is not energized is 1 year.

Select a Fan Unit which was manufactured less than 10 years ago and has been stored for less than a year without being energized. Perform operation check for the Fan Unit before you use it in normal operation.



Precautions for Correct Use

- Do not use a Fan Unit which was subject to a strong impact, such as dropping on the floor. A damaged bearing may cause a failure.
- Perform periodic cleaning procedures and remove dust from the Fan Unit. The service life of the Fan Unit may be reduced due to dust.



Additional Information

The date of manufacturing can be checked on the side of the Fan Unit.

DDMY gives the lot number, and “M” gives the following meaning.

1 to 9: January to September, X: October, Y: November, Z: December

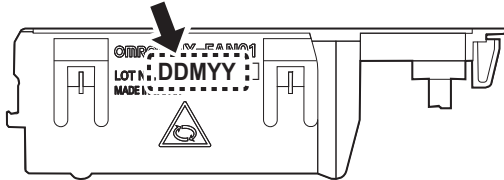

6-3-4 Procedure of Fan Unit Replacement



Precautions for Safe Use

Always turn OFF the power supply to the Controller before replacing the Fan Unit.

The Power Supply Unit may continue to supply power to the rest of the Controller for a few seconds after the power supply turns OFF. The PWR indicator is lit during this time. Confirm that the PWR indicator is not lit before you perform any of the above.

- 1** Turn OFF the power supply to the Controller.
- 2** Remove the Fan Unit while you push back the lever on top of the CPU Unit using a tool such as a flat-blade screwdriver.

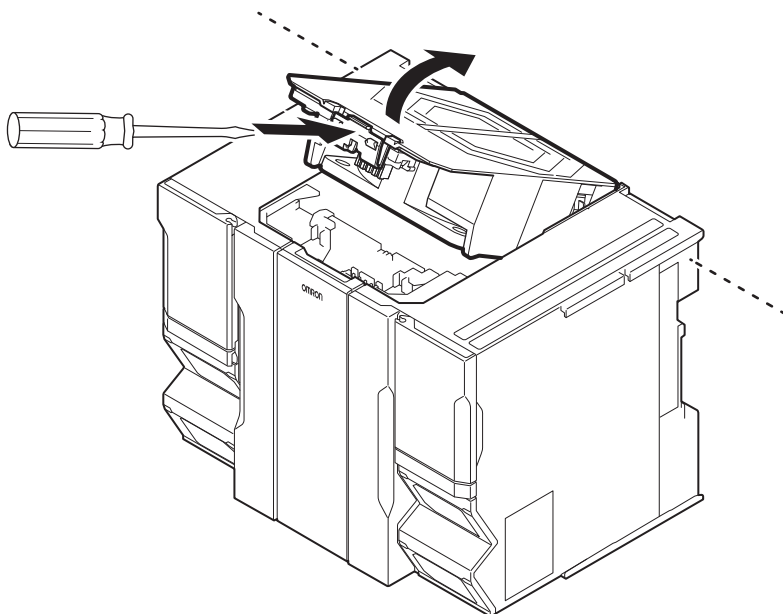

Precautions for Safe Use

Do not touch the heatsink inside the CPU Unit immediately after turning OFF the power supply. Doing so may result in burn injury.

3 Attach the new Fan Unit.

- (1) Put the locating part of the Fan Unit to the locating part on the back of the CPU Unit.

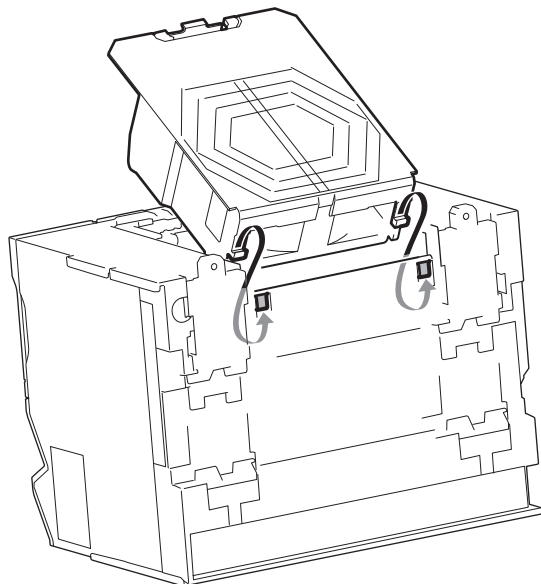

- (2) Use the locating part as a supporting point and push the Fan Unit into the CPU Unit.

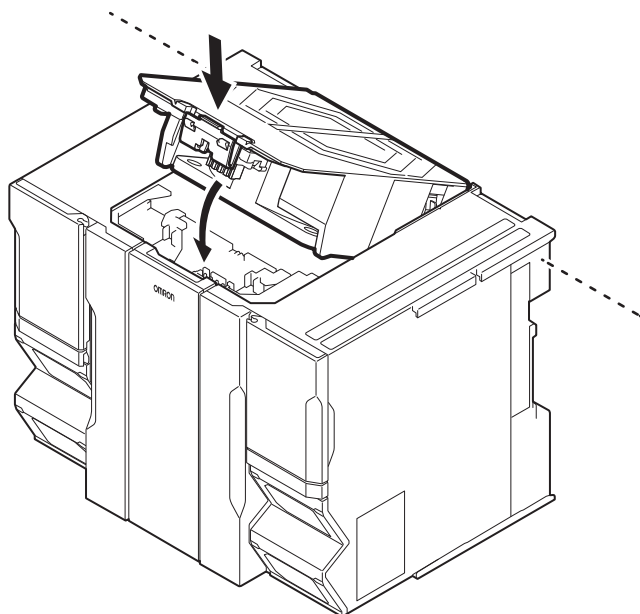

Make sure that the lever is securely locked and there is no lifting-off of the Fan Unit.

The power supply connection for the Fan Unit is established when it is attached to the CPU Unit. Wiring is not required.

4 Turn ON the power supply to the Controller and check the operation for about a minute.

Make sure that the fan does not generate abnormal noise or vibration, and a *Slow Fan* error does not occur.

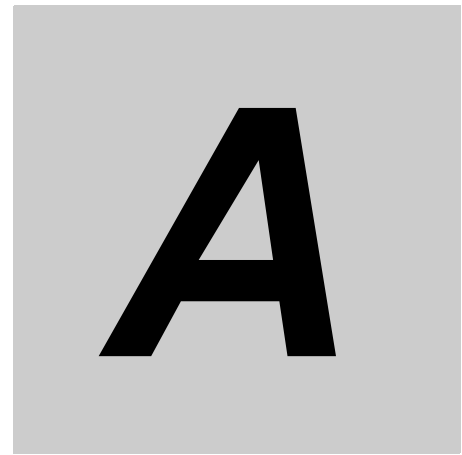

Appendices

The appendices provide the general specifications of the CPU Unit and Unit dimensions.

A-1 Specifications	A-2
A-2 Dimensions	A-3
A-2-1 NX-series CPU Units	A-3
A-2-2 End Cover	A-4
A-2-3 NX-series Power Supply Units	A-4
A-2-4 SD Memory Card	A-5
A-3 Version Information	A-6

A-1 Specifications

This section gives the specifications of the NX-series CPU Units.

Item		NX7-□□□□
Enclosure		Mounted in a panel
Grounding method		Ground to less than 100 Ω.
Dimensions (height × depth × width)		100 mm × 100 mm × 132 mm
Weight		880 g (including the End Cover)
Current consumption		40 W (including SD Memory Card and End Cover)
Operating environment	Ambient operating temperature	0 to 55°C
	Ambient operating humidity	10% to 95% (with no condensation)
	Atmosphere	Must be free from corrosive gases.
	Ambient storage temperature	-25 to 70°C (excluding battery and Fan Unit)
	Altitude	2,000 m max.
	Pollution degree	2 or less: Conforms to JIS B 3502 and IEC 61131-2.
	Noise immunity	2 kV on power supply line (Conforms to IEC 61000-4-4.)
	Overvoltage category	Category II: Conforms to JIS B 3502 and IEC 61131-2.
	EMC immunity level	Zone B
	Vibration resistance	Conforms to IEC 60068-2-6. 5 to 8.4 Hz with 3.5-mm amplitude, 8.4 to 150 Hz, acceleration of 9.8 m/s ² 100 min each in X, Y, and Z directions (10 sweeps of 10 min each = 100 min total)
Shock resistance	Conforms to IEC 60068-2-27. 147 m/s ² , 3 times in X, Y, and Z directions	
Battery	Life	2.5 years (at 25°C, Power ON time rate 0% (power OFF))
	Model	CJ1W-BAT01
Applicable standards*1	EC Directives	EN61131-2
	cULus	Listed UL508 and ANSI/ISA 12.12.01
	Shipbuilding Standards	---
	Other than the above.	KC

*1. Refer to the OMRON website (<http://www.ia.omron.com/>) or consult your OMRON representative for the most recent applicable standards for each model.

A-2 Dimensions

Dimensions of the CPU Units are shown as follows. The unit of dimension is millimeter.

A-2-1 NX-series CPU Units

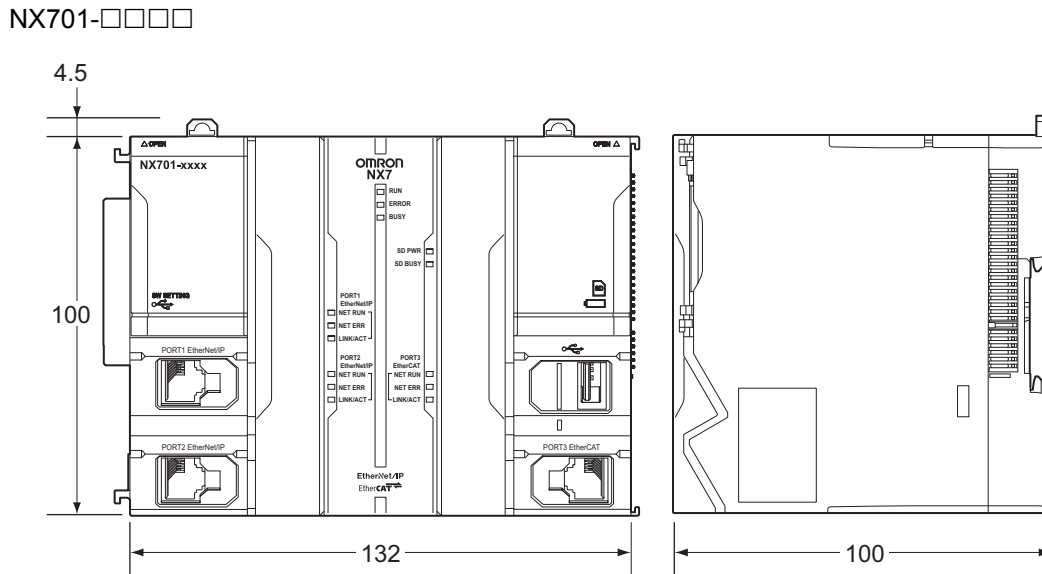

When a cable is connected (such as a communications cable)

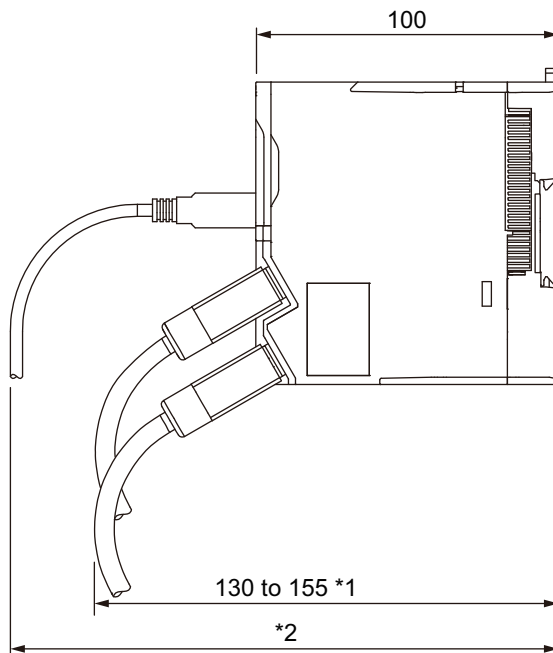

*1. This is the dimension from the back of the Unit to the communications cables.

130 mm: When an MPS588-C Connector is used.

155 mm: When an XS6G-T421-1 Connector is used.

*2. This dimension depends on the specifications of the commercially available USB cable. Check the specifications of the USB cable that is used.

A-2-2 End Cover

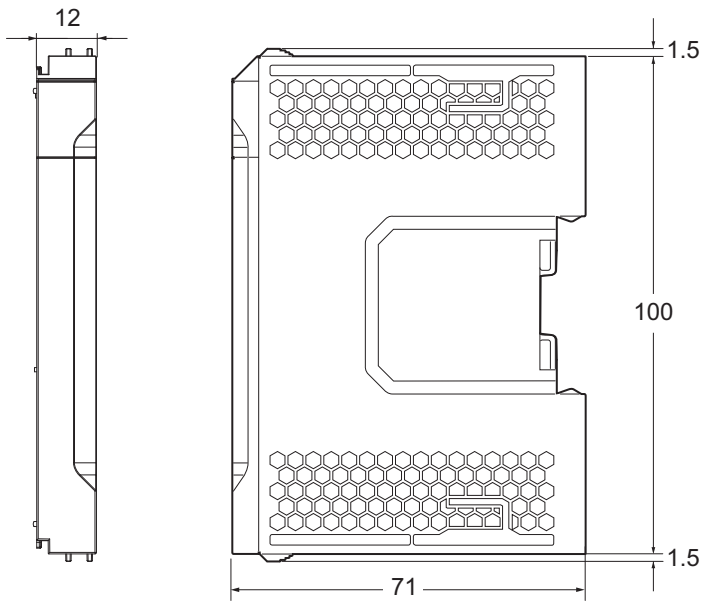

A-2-3 NX-series Power Supply Units

NX-PA9001

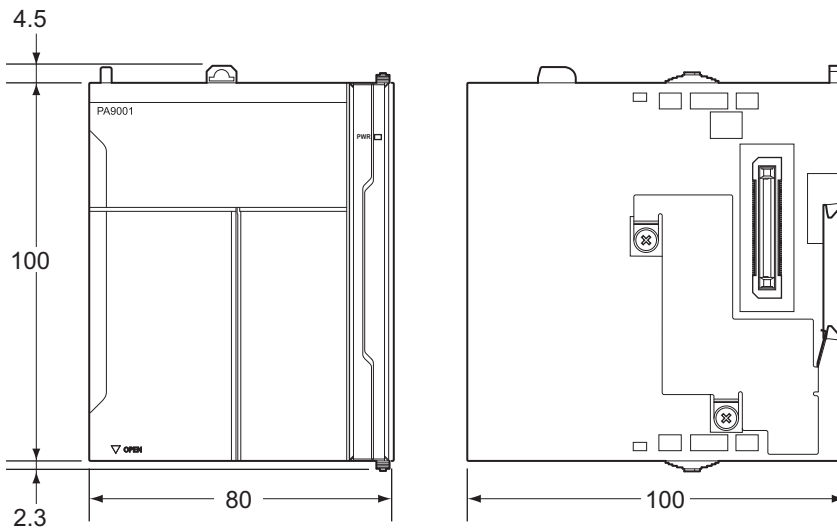

NX-PD7001

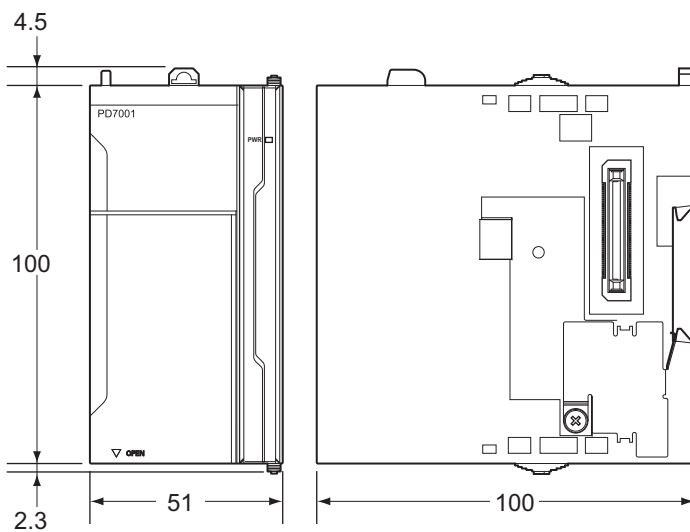

A-2-4 SD Memory Card

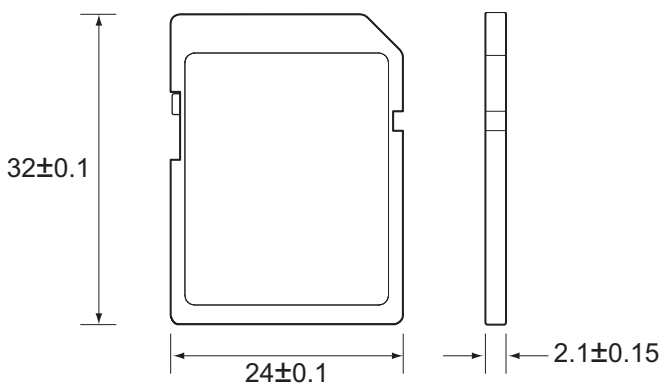

A-3 Version Information

This section describes the relationship between the unit versions of the NX-series CPU Units and the Sysmac Studio versions, and the functions that are supported for each unit version.

This section also describes how the unit version of NX-series CPU Units correspond to Sysmac Studio versions. Normally use the corresponding versions.

Unit Versions and Corresponding Sysmac Studio Versions

This following table gives the relationship between the unit versions of the NX-series CPU Units and the corresponding Sysmac Studio versions.

Unit version of CPU Unit	Corresponding version of Sysmac Studio
Ver.1.10	Ver.1.13

Specifications When Not Using the Sysmac Studio Version That Corresponds to the Unit Version of the CPU Unit

The specifications when you do not use the Sysmac Studio version that corresponds to the unit version of the NX-series CPU Unit are given in this section.

- **Using an Sysmac Studio Version 1.12 or Lower**

You cannot use an NX-series CPU Unit with Sysmac Studio version 1.12 or lower.

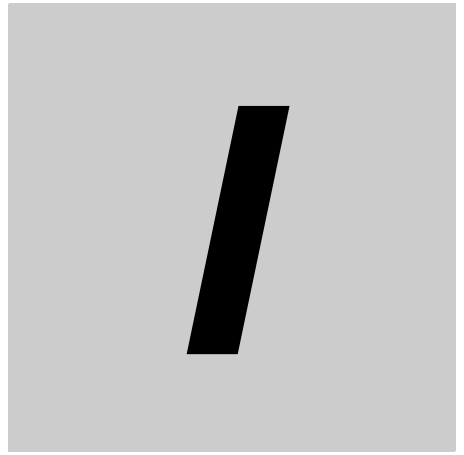

Index



Index

A

Applicable standards A-2
 Assumed causes 5-13, 5-16

B

Basic System Configuration 1-5, 2-2
 Battery 3-3, 3-8, 6-8, A-2
 Battery connector 3-3
 Battery Replacement Procedure 6-8
 Battery Service Life and Replacement Period 6-6
 Battery-backup Memory Check Error 5-36
 Built-in EtherCAT port 1-10, 2-3, 3-3
 Built-in EtherNet/IP port 1-9, 2-7, 3-3
 BUSY 3-5

C

Checking for errors 5-3, 5-8
 Cleaning 6-2
 Communications Cable 2-4, A-3
 Configuration Units 2-3
 Controller errors 5-5
 Controller events 5-4
 Controller information 5-5
 CPU Module 4-9, 4-16, 4-27
 CPU Rack 1-5, 2-3
 CPU Unit 2-3, 3-2
 CPU Unit Error 5-3
 CPU Unit operating status 5-2
 CPU Unit Overheat 5-35
 CPU Unit Reset 5-3

D

Daisy chain 4-46, 4-48
 DIN Track 4-14, 4-15, 4-17
 DIN Track Contact Plate 3-13, 4-36
 DIN Track Insulation Spacer 4-37
 DIN Track mounting hook 3-3, 3-13, 4-18
 DIP switch 3-3
 DIP Switch Setting Error 5-24
 Dropout prevention lock 3-13
 Dropout prevention lock release lever 3-13, 4-28

E

Earthing Methods 4-46
 Emergency Stop Circuit 4-7
 End Cover 2-4, 4-20
 End Plate 4-14, 4-15, 4-21
 Equipotential bonding system 4-46, 4-47
 ERROR 3-5, 5-2

Error reset 5-6
 Error status variables 5-10
 EtherCAT Network Configuration 1-5, 2-3
 EtherCAT Slave 2-4
 Event codes 5-13, 5-16
 Event levels 5-4
 Event log 4-5, 5-6
 Event Log Save Error 5-49
 Event names 5-13, 5-16

F

Fail-safe Circuits 4-6
 Fan Unit 3-3, 3-8, 4-12
 Fatal Errors in the CPU Unit 5-3
 Functional Grounding 4-35, 4-50

G

Get EtherCAT Error Status 5-10
 Get EtherNet/IP Error Status 5-10
 Get Motion Control Error Status 5-10
 Get PLC Controller Error Status 5-10
 GetECError (Get EtherCAT Error Status) 5-10
 GetEIPError (Get EtherNet/IP Error Status) 5-10
 GetMCError (Get Motion Control Error Status) 5-10
 GetPLCError (Get PLC Controller Error Status) 5-10
 GR 3-14, 4-35, 4-50
 Grounding 4-35, 4-46

I

ID Information Indication 3-3, 3-9
 Illegal User Program 5-42
 Illegal User Program Execution ID 5-42
 Indicator 3-4, 5-2, 5-8
 Information 5-4
 Inrush current 3-11
 Installation Dimensions 4-29
 Installation Height 4-30
 Installation in Cabinets or Control Panels 4-10
 Installation Method in Control Panels 4-11
 Instructions that read error status 5-10
 Interlock Circuits 4-8
 Internal Bus Check Error 5-24

L

LG 3-14, 4-35, 4-50
 LINK/ACT 3-7
 Lot number 3-9
 Low Battery Voltage 5-34

M

MAC addresses	3-9
Main Memory Check Error	5-28
Major Fault Level	5-4, 5-7
Minor Fault Level	5-4

N

NET ERR	3-7, 5-9
NET RUN	3-6, 3-7
Network Configuration	1-6, 2-7
Non-fatal Errors in the CPU Unit	5-4
Non-volatile Memory Data Corrupted	5-27, 5-30
Non-volatile Memory Life Exceeded	5-25
Non-volatile Memory Restored or Formatted	5-26

O

Observations	5-4
Operating environment	A-2
Operating Mode at Startup	4-3
Operating Procedure	1-12
Operation Status Indicators	3-4
Operation until Operation Ready Status	4-2
Order of Powering	4-7
Output capacity	3-11
Outputs turned OFF	5-6

P

Partial Fault Level	5-4
Periodic Inspection Items	6-3
Peripheral USB port	3-3
Power consumption	3-11, A-2
Power OFF detection time	4-3
Power OFF Operation	4-3
Power ON time rate	6-6, A-2
Power supply connector	3-3
Power Supply Error	5-3
Power supply input	3-14
Power Supply Unit	2-4, 3-11
Power supply voltage	3-11
Power Supply Wiring	4-7, 4-31
Protective Grounding	4-35, 4-50
PWR	3-13, 5-2

R

Real-Time Clock Failed	5-34
Real-Time Clock Stopped	5-33
Restricted region	4-16, 4-27
RUN	3-5, 5-2
RUN Output	3-11, 3-14, 4-32, 4-34

S

Safe Mode	3-3
-----------------	-----

SD BUSY	3-5
SD Memory Card	2-4, 4-23
SD Memory Card Access Power OFF Error	5-39
SD Memory Card connector	3-3
SD Memory Card Data Corrupted	5-39
SD Memory Card Invalid Format	5-37
SD Memory Card Invalid Type	5-36
SD Memory Card Life Exceeded	5-37
SD Memory Card power supply switch	3-3
SD Memory Card Restored or Formatted	5-38
SD PWR	3-5
Slider	3-13, 4-17
Star earthing	4-46, 4-47
Startup	3-5
Support Software	1-5, 1-7
Sysmac Studio	3-15
System Initialization Error	5-3
System-defined variables	5-10

T

Terminal Block	3-14
Troubleshooter	5-10
Troubleshooting Function	5-9

U

Unit hookup guides	3-3, 4-20
Unit Version	3-9, A-6
User Program/Controller Configurations and Setup Transfer Error	5-41

W

Wiring Duct	4-12
Write Protection Key	3-10

OMRON Corporation Industrial Automation Company
Tokyo, JAPAN

Contact: www.ia.omron.com

Regional Headquarters

OMRON EUROPE B.V.

Wegalaan 67-69, 2132 JD Hoofddorp
The Netherlands
Tel: (31)2356-81-300/Fax: (31)2356-81-388

OMRON ELECTRONICS LLC

2895 Greenspoint Parkway, Suite 200
Hoffman Estates, IL 60169 U.S.A
Tel: (1) 847-843-7900/Fax: (1) 847-843-7787

OMRON ASIA PACIFIC PTE. LTD.

No. 438A Alexandra Road # 05-05/08 (Lobby 2),
Alexandra Technopark,
Singapore 119967
Tel: (65) 6835-3011/Fax: (65) 6835-2711

OMRON (CHINA) CO., LTD.

Room 2211, Bank of China Tower,
200 Yin Cheng Zhong Road,
PuDong New Area, Shanghai, 200120, China
Tel: (86) 21-5037-2222/Fax: (86) 21-5037-2200

Authorized Distributor:

© OMRON Corporation 2015 All Rights Reserved.
In the interest of product improvement,
specifications are subject to change without notice.

Cat. No. W535-E1-01

0415